

# THD3C42A0



## Description

The THD3C42A0 combines accurate timing circuitry with high power, solid-state switching. It can switch motors, lamps, and heaters directly without a contactor. The THD3C42A0 has equal on and off time delays. A single  $R_T$  sets both time delays. You can reduce labor, component cost, and increase reliability with these small, easy-to-use, Digi-Power timers.

### Operation (Recycling Flasher - ON Time First)

Upon application of input voltage, the output energizes and the T1 ON time begins. At the end of the ON time, the output de-energizes and the T2 OFF time begins. At the end of the OFF time, the output energizes and the cycle repeats as long as input voltage is applied.

**Reset:** Removing input voltage resets the output and time delays, and returns the sequence to T1 ON time.

### Operation (Recycling Flasher - OFF Time First)

Upon application of input voltage, the T2 OFF time begins. At the end of the OFF time, the T1 ON time begins and the load energizes. At the end of T1, T2 begins and the load de-energizes. This cycle repeats until input voltage is removed.

**Reset:** Removing input voltage resets the output and the sequence to T2 OFF time.

## Wiring Diagram

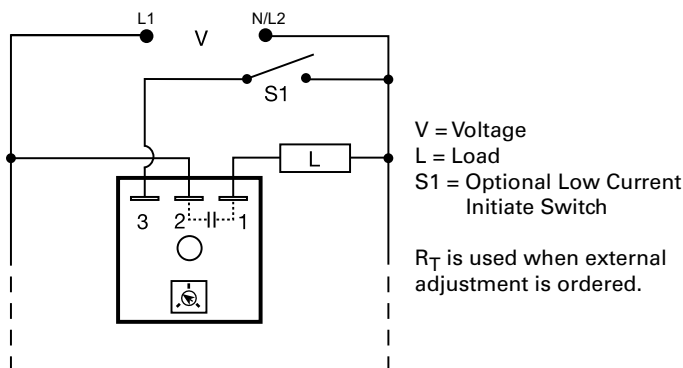

## Features & Benefits

FEATURES	BENEFITS
<b>Microcontroller based</b>	Repeat Accuracy + / - 0.5%, Factory calibration + / - 1%
<b>Compact, low cost design</b>	Allows flexibility for OEM applications and reduces labor and component costs
<b>High load currents up to 20A, 200A inrush</b>	Allows direct operation of motors, lamps, and heaters without a contactor
<b>Totally solid state and encapsulated</b>	No moving parts to arc and wear out over time and encapsulated to protect against shock, vibration, and humidity
<b>Metalized mounting surface</b>	Facilitates heat transfer in high current applications

## Accessories



### P1004-95, P1004-95-X Versa-Pot

Panel mountable, industrial potentiometer recommended for remote time delay adjustment.



### P0700-7 Versa-Knob

Designed for 0.25 in. (6.35 mm) shaft of Versa-Pot. Semi-gloss industrial black finish.



### P1015-13 (AWG 10/12), P1015-64 (AWG 14/16) Female Quick Connect

These 0.25 in. (6.35 mm) female terminals are constructed with an insulator barrel to provide strain relief.



### P1015-18 Quick Connect to Screw Adapter

Screw adapter terminal designed for use with all modules with 0.25 in. (6.35 mm) male quick connect terminals.

# THD3C42A0

## External Resistance vs. Time Delay

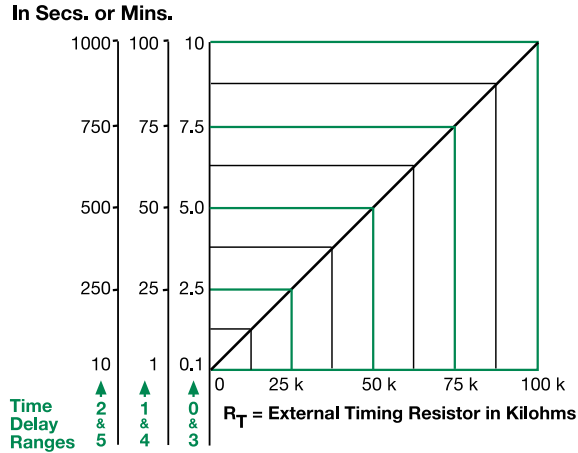

**This chart applies to externally adjustable part numbers.**  
The time delay is adjustable over the time delay range selected by varying the resistance across the  $R_T$  terminals; as the resistance increases the time delay increases.  
When selecting an external  $R_T$ , add the tolerances of the timer and the  $R_T$  for the full time range adjustment.  
**Examples:** 1 to 50 S adjustable time delay, select time delay range 1 and a 50 K ohm  $R_T$ . For 1 to 100 S use a 100 K ohm  $R_T$ .

## Function Diagrams

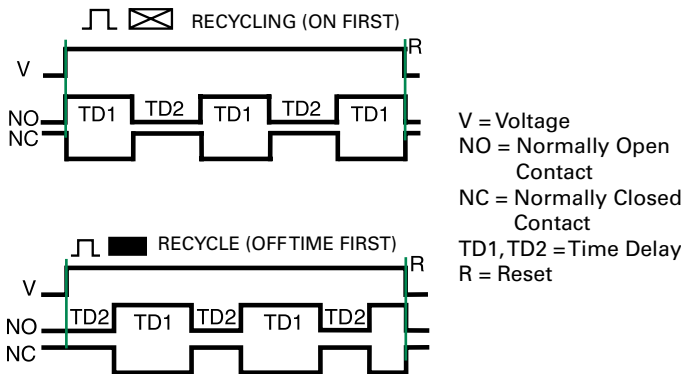

## Specifications

<b>Time Delay Range Adjustment</b>	0.1s - 1000m in 6 adjustable ranges or fixed Single variable resistor changes both the on & off times equally
<b>Repeat Accuracy Tolerance (Factory Calibration)</b>	$\pm 0.5\%$ or 20ms, whichever is greater
<b>Reset Time</b>	$\leq 150$ ms
<b>Time Delay vs Temp. &amp; Voltage</b>	$\leq \pm 2\%$
<b>Input Voltage Tolerance</b>	24, 120, or 230VAC $\pm 20\%$
<b>AC Line Frequency</b>	50/60 Hz
<b>Power Consumption</b>	$\leq 2$ VA
<b>Output Type</b>	Solid state
<b>Maximum Load Current</b>	<b>Steady State</b> 20A <b>Inrush**</b> 200A
<b>Minimum Load Current</b>	100mA
<b>Voltage Drop</b>	$\approx 2.5$ V at rated current
<b>OFF State Leakage Current</b>	$\approx 5$ mA @ 230VAC
<b>Protection</b>	Encapsulated
<b>Circuitry</b>	$\geq 2000$ V RMS terminals to mounting surface
<b>Dielectric Breakdown</b>	$\geq 100$ M $\Omega$
<b>Insulation Resistance</b>	
<b>Mechanical Mounting**</b>	Surface mount with one #10 (M5 x 0.8) screw
<b>Dimensions</b>	<b>H</b> 50.8 mm (2"); <b>W</b> 50.8 mm (2"); <b>D</b> 38.4 mm (1.51")
<b>Termination</b>	0.25 in. (6.35 mm) male quick connect terminals
<b>Environmental</b>	
<b>Operating/Storage Temperature</b>	-40° to 60°C / -40° to 85°C
<b>Humidity</b>	95% relative, non-condensing
<b>Weight</b>	$\approx 3.9$ oz (111 g)

\*\*Must be bolted to a metal surface using the included heat sink compound. The maximum mounting surface temperature is 90°C. Inrush: Non-repetitive for 16ms.