

NHD-7.0-800480WF-20 Controller Board

TFT Controller Evaluation Board

NHD-	Newhaven Display
7.0-	7.0" Diagonal
800480-	320xRGBx240 pixels
WF-	Model
20-	20-POS FFC interface (8-bit data) SSD1963 Controller

Newhaven Display International, Inc.

2511 Technology Drive, Suite 101

Elgin IL, 60124

Ph: 847-844-8795

Fax: 847-844-8796

www.newhavendisplay.com

nhtech@newhavendisplay.com

nhsales@newhavendisplay.com

Document Revision History

Revision	Date	Description	Changed by
0	6/1/2012	Initial Release	AK

Functions and Features

- To use for testing, evaluating, or in final production with NHD-7.0-800480WF-A displays.

Mechanical Drawing

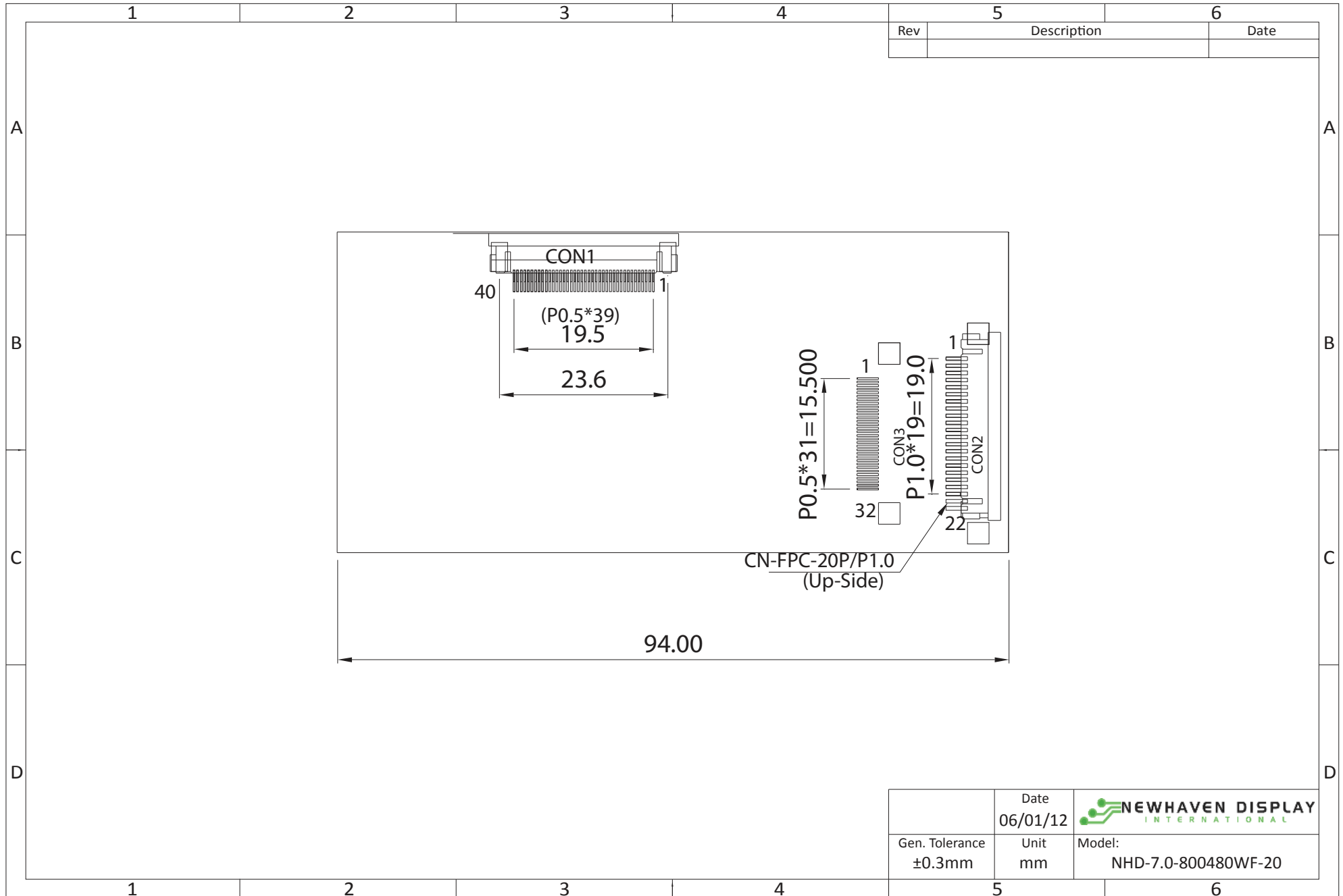

Pin Description

Note: CON2 has a 20-POS FFC connector assembled, pins 21, 22 not connected.

CON2 (SSD1963 input from user's MPU):

Pin No.	Symbol	Connection	Function Description
1	GND	Power Supply	Ground
2	VDD	Power Supply	Power supply for logic (+3.3V)
3	NC	-	No Connect
4	D/C#	MPU	Register Select signal: 1=Data, 0=Command
5	WR#	MPU	Active LOW Write signal (8080 mode) Read/Write signal (6800 mode)
6	RD#	MPU	Active LOW Read signal (8080 mode) Edge trigger Enable signal (6800 mode)
7-14	DB0~DB7	MPU	8-bit bi-directional data bus
15	CS#	MPU	Active LOW Chip Select signal
16	NC	-	No Connect
17	NC	-	No Connect
18	RST#	MPU	Active LOW Reset signal
19	NC	-	No Connect
20	NC	-	No Connect

LCD connector: 1.0mm pitch, 20-Conductor FFC, top contact

Recommended connection: 1.0mm pitch, 20-conductor FFC cable

CON1 (SSD1963 output to display panel):

Pin No.	Symbol	Connection	Function Description
1	GND	Power Supply	Power Ground
2	GND	Power Supply	Power Ground
3	NC	-	No connect
4-7	VDD	Power Supply	Power Supply (+3.3V)
8	NC	-	No connect
9	DE	MPU	Data Enable
10-12	GND	Power Supply	Power Ground
13-15	B5-B3	MPU	Blue B5 (MSB) to B3
16	GND	Power Supply	Power Ground
17-19	B2-B0	MPU	Blue B2 – B0(LSB)
20	GND	Power Supply	Power Ground
21-23	G5-G3	MPU	Green B5 (MSB) to B3
24	GND	Power Supply	Power Ground
25-27	G2-G0	MPU	Green B2 – B0(LSB)
28	GND	Power Supply	Power Ground
29-31	R5-R3	MPU	Red B5 (MSB) to B3
32	GND	Power Supply	Power Ground
33-35	R2-R0	MPU	Red B2 – B0(LSB)
36-37	GND	Power Supply	Power Ground
38	DCLK	MPU	Clock (Falling edge triggered)
39-40	GND	Power Supply	Power Ground

LCD connector: 0.5mm pitch, 40-Conductor FFC, Bottom contact

Recommended connection: 0.5mm pitch, 40-conductor FFC cable

Electrical Characteristics

Item	Symbol	Condition	Min.	Typ.	Max.	Unit
Operating Temperature Range	Top	Absolute Max	-20	-	+70	°C
Storage Temperature Range	Tst	Absolute Max	-30	-	+80	°C
Supply Voltage	VDD		3.0	3.3	3.5	V
Supply Current	IDD		-	5	30	mA
Input High Voltage	VIH		0.8*VDD	-	VDD+0.5	V
Input Low Voltage	VIL		0	-	0.2*VDD	V
Output High Voltage	VOH		0.8*VDD	-	VDD	V
Output Low Voltage	VOL		0	-	0.2*VDD	V

Controller Information

Built-in SSD1963. Download specification at http://www.newhavendisplay.com/app_notes/SSD1963.pdf

Pixel Data Format

		D[7]	D[6]	D[5]	D[4]	D[3]	D[2]	D[1]	D[0]
8 bits	1 st	R7	R6	R5	R4	R3	R2	R1	R0
	2 nd	G7	G6	G5	G4	G3	G2	G1	G0
	3 rd	B7	B6	B5	B4	B3	B2	B1	B0

Timing Characteristics

Parallel 8080-series interface timing:

Symbol	Parameter	Min	Typ	Max	Unit
f_{MCLK}	System Clock Frequency*	1	-	110	MHz
t_{MCLK}	System Clock Period*	$1/f_{MCLK}$	-	-	ns
t_{PWCSL}	Control Pulse High Width Write Read	13 30	$1.5 * t_{MCLK}$ $3.5 * t_{MCLK}$	-	ns
t_{PWCSH}	Control Pulse Low Width Write (next write cycle) Write (next read cycle) Read	13 80 80	$1.5 * t_{MCLK}$ $9 * t_{MCLK}$ $9 * t_{MCLK}$	-	ns
t_{AS}	Address Setup Time	1	-	-	ns
t_{AH}	Address Hold Time	2	-	-	ns
t_{DSW}	Write Data Setup Time	4	-	-	ns
t_{DHW}	Write Data Hold Time	1	-	-	ns
t_{PWLW}	Write Low Time	12	-	-	ns
t_{DHR}	Read Data Hold Time	1	-	-	ns
t_{ACC}	Access Time	32	-	-	ns
$t_{PWL R}$	Read Low Time	36	-	-	ns
t_R	Rise Time	-	-	0.5	ns
t_F	Fall Time	-	-	0.5	ns
t_{CS}	Chip select setup time	2	-	-	ns
t_{CSH}	Chip select hold time to read signal	3	-	-	ns

* System Clock denotes external input clock (PLL-bypass) or internal generated clock (PLL-enabled)

Write Cycle:

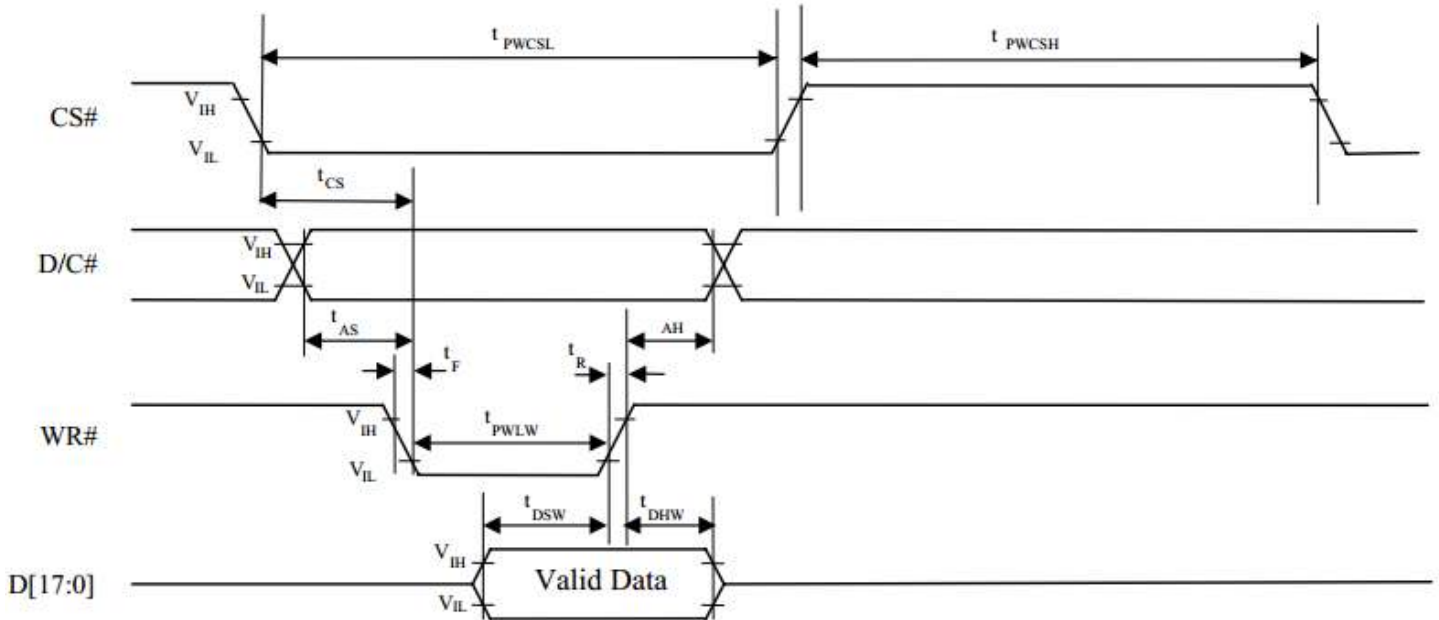

Read Cycle:

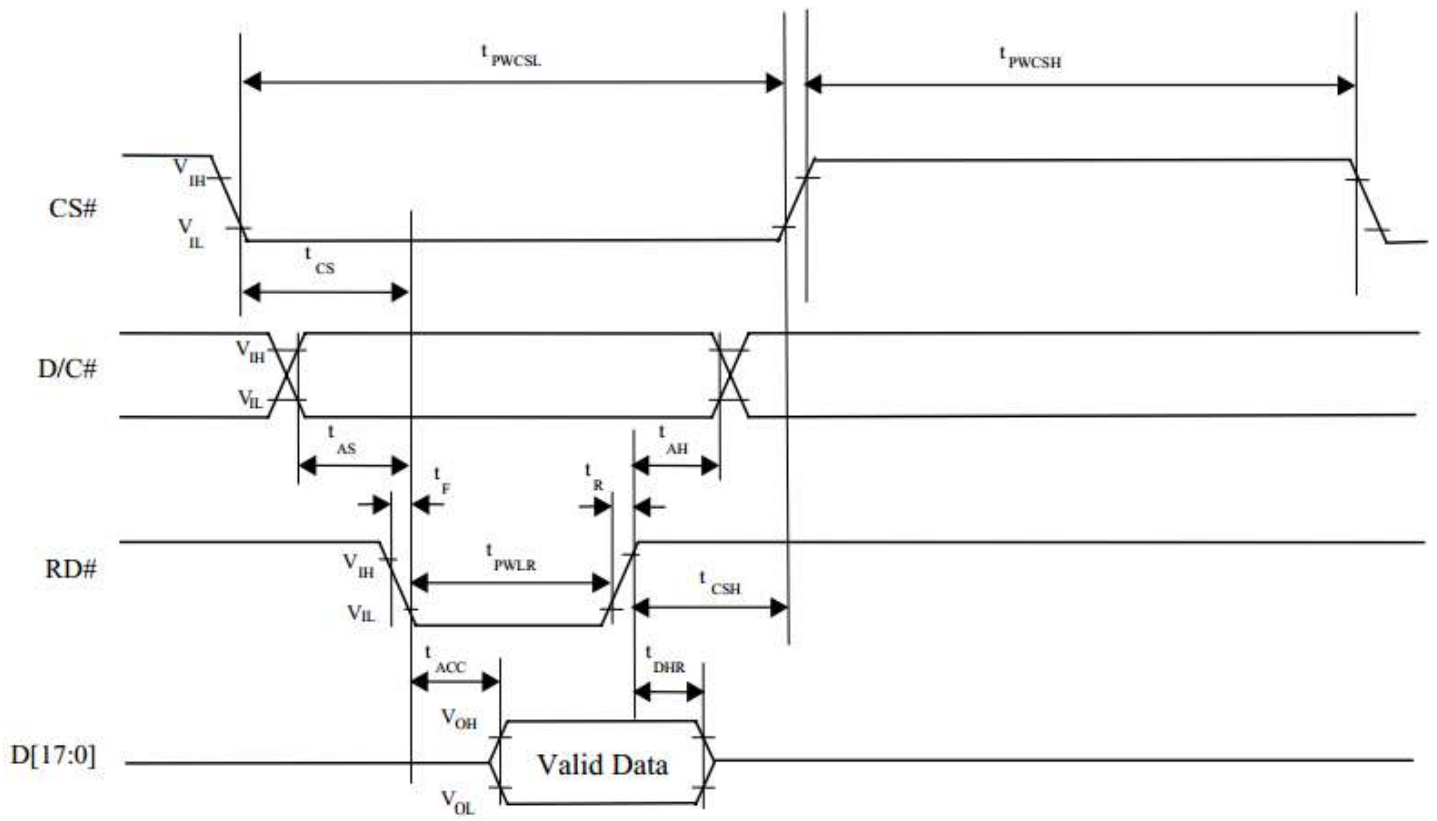

Parallel LCD Interface Timing:

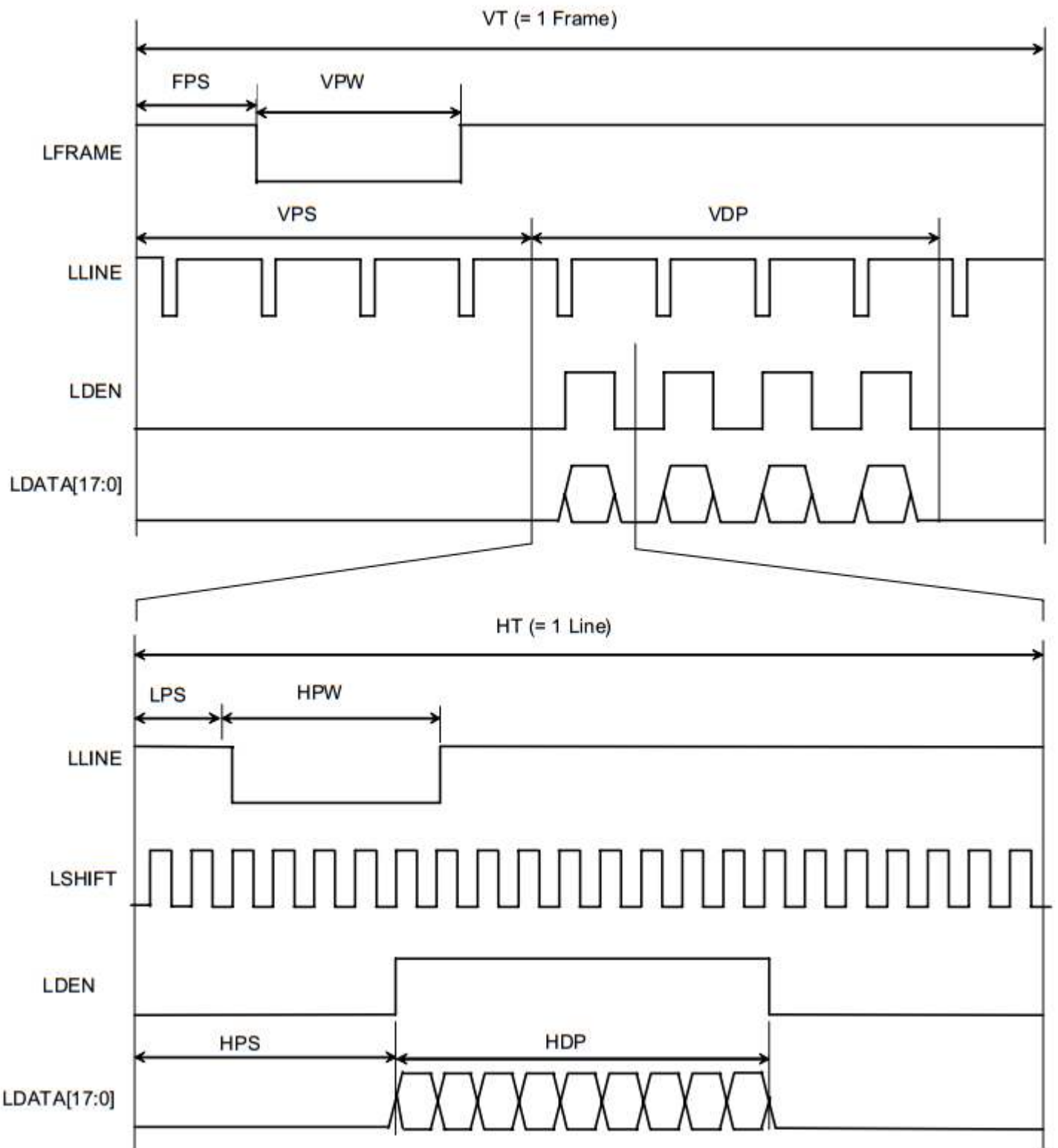

Quality Information

Test Item	Content of Test	Test Condition	Note
High Temperature storage	Endurance test applying the high storage temperature for a long time.	+80°C , 200hrs	2
Low Temperature storage	Endurance test applying the low storage temperature for a long time.	-30°C , 200hrs	1,2
High Temperature Operation	Endurance test applying the electric stress (voltage & current) and the high thermal stress for a long time.	+70°C 200hrs	2
Low Temperature Operation	Endurance test applying the electric stress (voltage & current) and the low thermal stress for a long time.	-20°C , 200hrs	1,2
High Temperature / Humidity Operation	Endurance test applying the electric stress (voltage & current) and the high thermal with high humidity stress for a long time.	+60°C , 90% RH , 96hrs	1,2
Thermal Shock resistance	Endurance test applying the electric stress (voltage & current) during a cycle of low and high thermal stress.	-20°C,30min -> 25°C,5min -> 70°C,30min = 1 cycle 10 cycles	
Vibration test	Endurance test applying vibration to simulate transportation and use.	10-55Hz , 15mm amplitude. 60 sec in each of 3 directions X,Y,Z For 15 minutes	3
Static electricity test	Endurance test applying electric static discharge.	VS=800V, RS=1.5kΩ, CS=100pF One time	

Note 1: No condensation to be observed.

Note 2: Conducted after 4 hours of storage at 25°C, 0%RH.

Note 3: Test performed on product itself, not inside a container.

Precautions for using LCDs/LCMs

See Precautions at www.newhavendisplay.com/specs/precautions.pdf

Warranty Information and Terms & Conditions

http://www.newhavendisplay.com/index.php?main_page=terms