

SPRING FINGER GASKET WITH TWO POINTS OF CONTACT. COMPLIES WITH (SFP) MSA BOARD AND BEZEL LOCATIONS.

TABS USED TO MOUNT LIGHT PIPE COVER

SEE NOTE 6, 7 & 8

ONE PIECE DESIGN SECURLY FASTENED

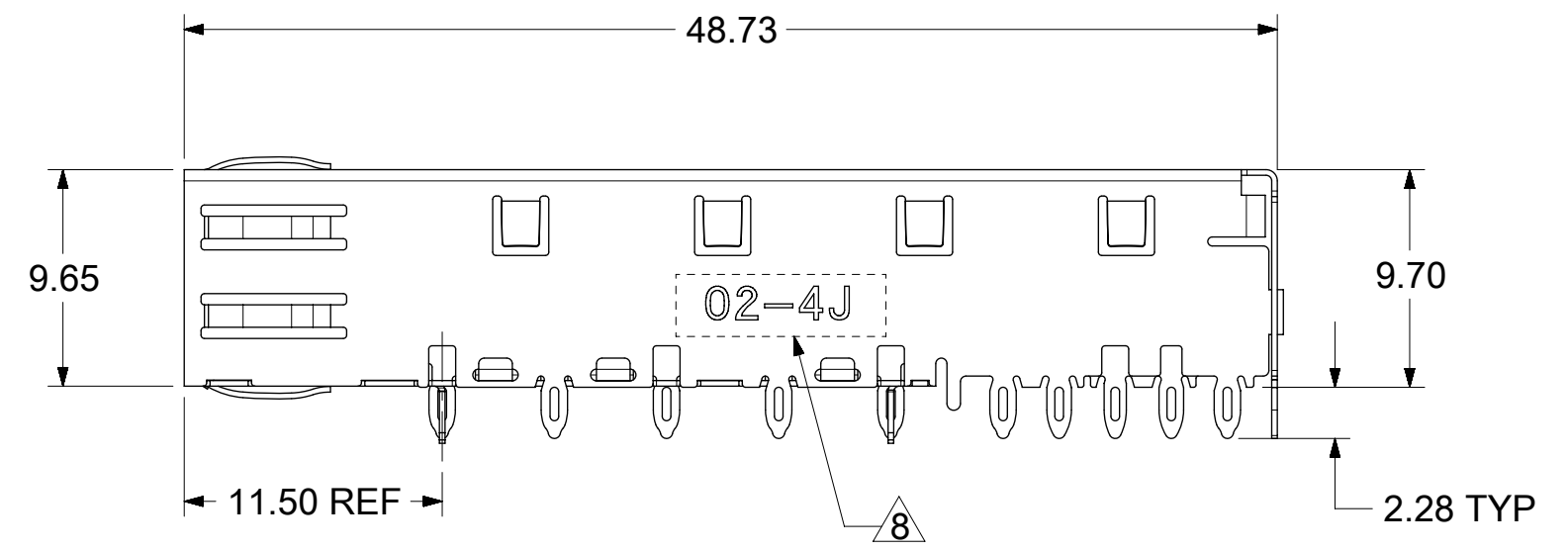
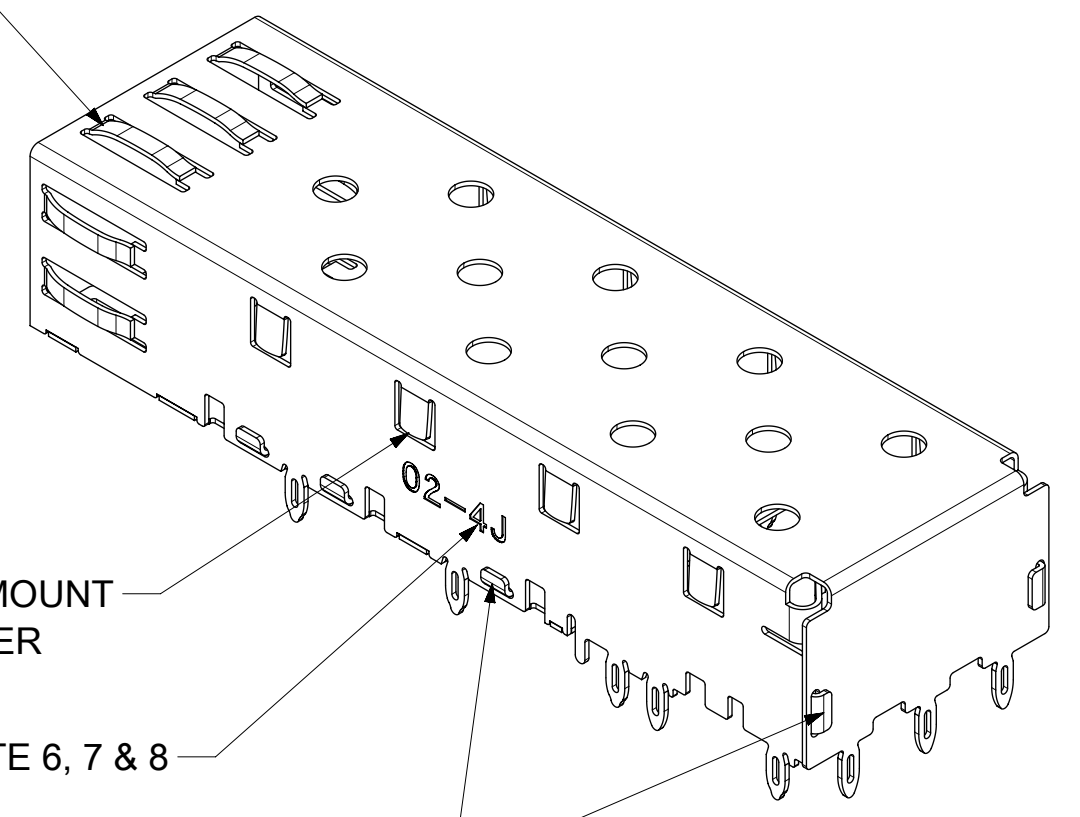

NOTES:

- PRESS FIT LEGS, 2.28mm LONG.
1.57mm MINIMUM PCB THICKNESS.
- THIS CAGE IS FOR SINGLE SIDED USE ONLY.
- CAN BE USED WITH THE FOLLOWING LIGHT PIPE PART NUMBERS:
747260001 - LIGHT PIPE FROM BACK TO TOP
(REFER TO DOCUMENT SD-74726-001)
747260002 - LIGHT PIPE FROM SIDE TO TOP
(REFER TO DOCUMENT SD-74726-002)
- MATERIAL: COPPER ALLOY
PLATING: PRE-PLATED WITH NICKEL
- NO RoHS EXEMPTIONS.
- REVISION LETTER IS FOLLOWING MOLEX 3D MODEL.
- INSERT TO CHANGE ENGRAVING FOR LAST TWO DIGITS OF PART NUMBER OR 3D REVISION.
- INSERT TO IDENTIFY ADDITIONAL TOOLING STARTING WITH TOOL #2 AS FOLLOWS:
LAST TWO DIGITS OF PART NUMBER, TOOL NUMBER AND ENGINEERING DRAWING REVISION LETTER (INTERNAL USE).
(E.G., 02-4J)

| | | | | | | | | | | | |
|-----------------|-------|---|--|--|---------------------------------------|------------------------|-----------------|--|--------------|--|-----------------|
| QUALITY SYMBOLS | | THIS DRAWING CONTAINS INFORMATION THAT IS PROPRIETARY TO MOLEX ELECTRONIC TECHNOLOGIES, LLC AND SHOULD NOT BE USED WITHOUT WRITTEN PERMISSION | | | | | | | | | |
| ▽ = 0 | ▽ = 0 | SEE REVISION TABLE | EC NO: 169609 DRWN: MKEMPEGOWDA CHKD: EWANG07 REV / APPR: RCHEN08 | 2017/12/11 2017/12/15 2017/12/16 | GENERAL TOLERANCES (UNLESS SPECIFIED) | | DIMENSION UNITS | SCALE | molex | | |
| ▽ = 0 | ▽ = 0 | | | | ANGULAR TOL ± 1.0 ° | | mm | 3:1 | | | |
| ▽ = 0 | ▽ = 0 | | | | 4 PLACES ± | DRWN BY | DATE | SFP ONE PIECE CAGE PRESS-FIT (0.090 LEGS) | | | |
| ▽ = 0 | ▽ = 0 | | | | 3 PLACES ± | MKEMPEGOWDA | 2017/12/11 | | | | |
| ▽ = 0 | ▽ = 0 | | | | 2 PLACES ± 0.13 | CHKD BY | DATE | PRODUCT CUSTOMER DRAWING | | | |
| ▽ = 0 | ▽ = 0 | 1 PLACE ± 0.25 | EWANG07 | 2017/12/15 | | | | | | | |
| ▽ = 0 | ▽ = 0 | 0 PLACES ± | APPR BY | DATE | SERIES | MATERIAL NUMBER | CUSTOMER | DOCUMENT NUMBER 747370002 | | | |
| ▽ = 0 | ▽ = 0 | DRAFT WHERE APPLICABLE MUST REMAIN WITHIN DIMENSIONS | RCHEN08 | 2017/12/16 | 74737 | 747370002 | | | | | DOC TYPE PSD |
| ▽ = 0 | ▽ = 0 | | J | | DRAWING SIZE | THIRD ANGLE PROJECTION | C | | | | |

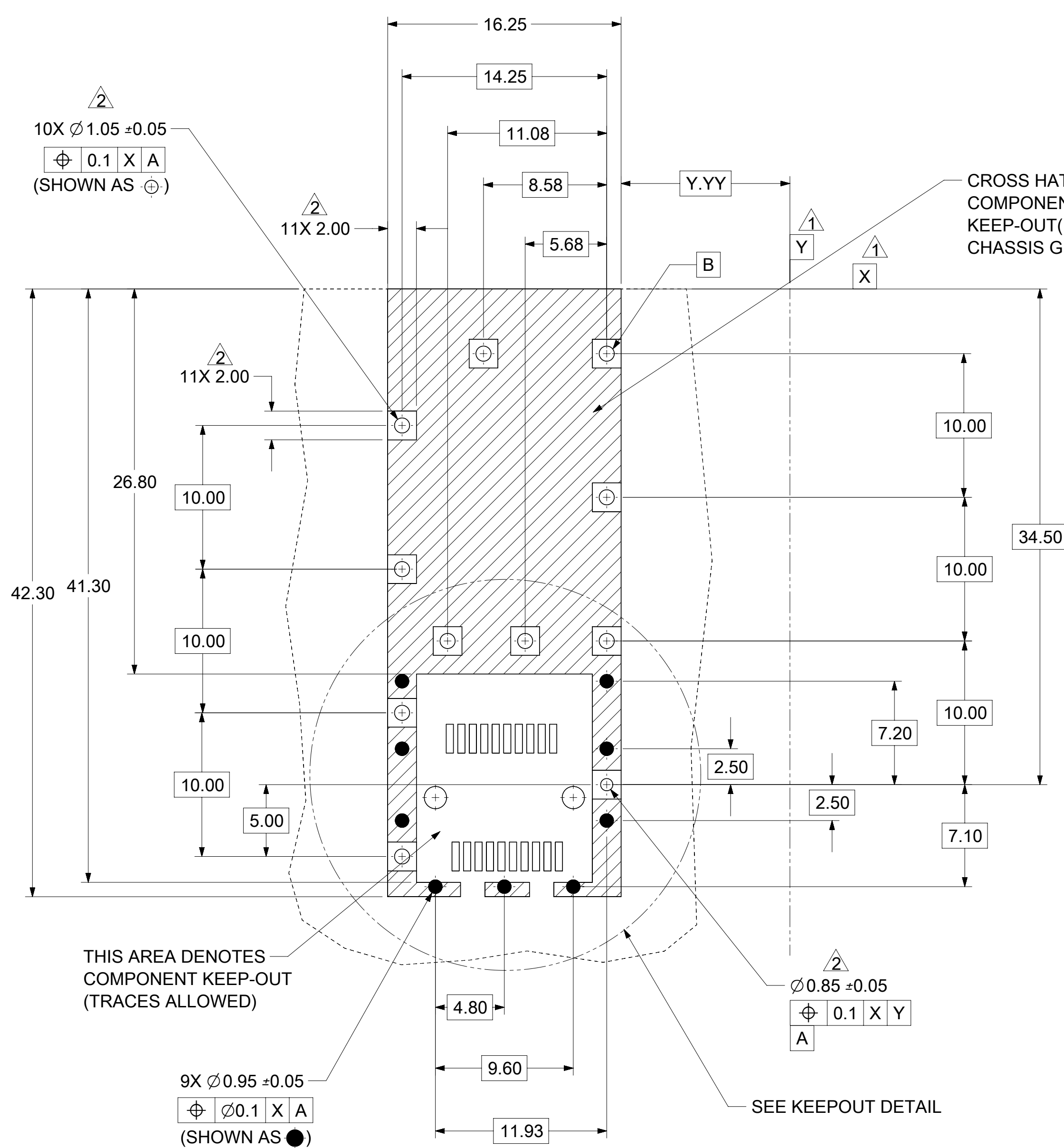

CROSS HATCHED AREA DENOTES COMPONENTS AND TRACE KEEP-OUT (EXCEPT CHASSIS GROUND)

THIS AREA DENOTES COMPONENT KEEP-OUT (TRACES ALLOWED)

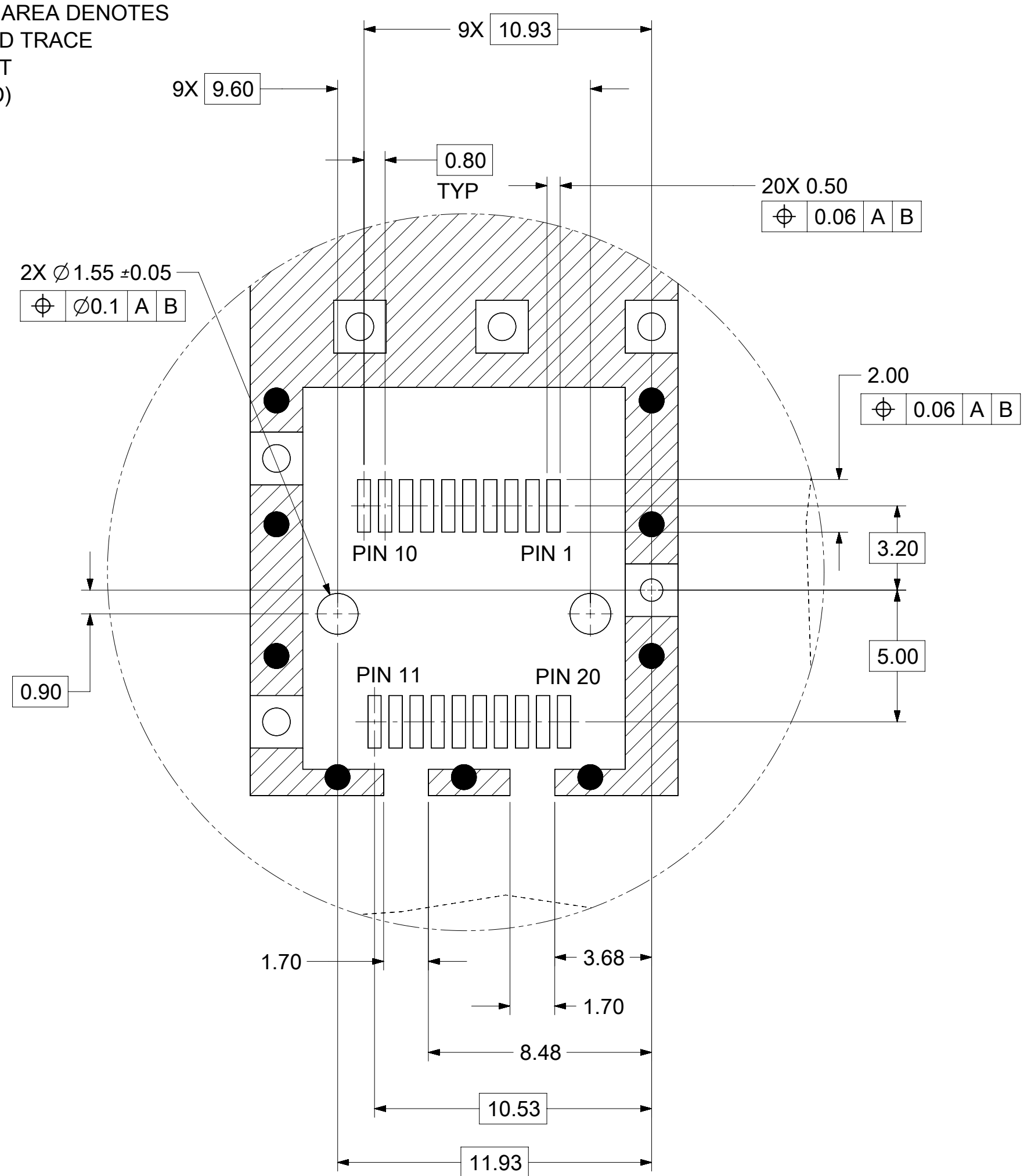

KEEPOUT DETAIL SCALE 6:1

- 1 DATUM AND BASIC DIMENSIONS ESTABLISHED BY CUSTOMER.
- 2 PADS AND VIAS ARE CHASSIS GROUND.
- 3 HOLE LAYOUT SHOWN IS FOR SINGLE SIDED MOUNTING ONLY.
- 4. CONNECTOR PAD LAYOUT PER SFP MSA, WILL ACCOMODATE MOLEX CONNECTOR SERIES 74441 OR EQUIVALENT.

| | | | | | | | |
|-----------------|-------|---|---------------------------------------|--|------------------------|------------|--|
| QUALITY SYMBOLS | | THIS DRAWING CONTAINS INFORMATION THAT IS PROPRIETARY TO MOLEX ELECTRONIC TECHNOLOGIES, LLC AND SHOULD NOT BE USED WITHOUT WRITTEN PERMISSION | | | | | |
| ▽ = 0 | ▽ = 0 | SEE REVISION TABLE EC NO: 169609 DRWN: MKEMPEGOWDA CHKD: EWANG07 REV / APPR: RCHEN08 | GENERAL TOLERANCES (UNLESS SPECIFIED) | | DIMENSION UNITS | SCALE | |
| ▽ = 0 | ▽ = 0 | | ANGULAR TOL ± 1.0 ° | | mm | 4:1 | |
| ▽ = 0 | ▽ = 0 | | 4 PLACES ± | 3 PLACES ± | DRWN BY | DATE | |
| ▽ = 0 | ▽ = 0 | | 2 PLACES ± 0.13 | 1 PLACE ± 0.25 | MKEMPEGOWDA | 2017/12/11 | |
| ▽ = 0 | ▽ = 0 | | 0 PLACES ± | DRAFT WHERE APPLICABLE MUST REMAIN WITHIN DIMENSIONS | CHKD BY | DATE | |
| ▽ = 0 | ▽ = 0 | | | | EWANG07 | 2017/12/15 | |
| ▽ = 0 | ▽ = 0 | | | APPR BY | DATE | | |
| ▽ = 0 | ▽ = 0 | | | RCHEN08 | 2017/12/16 | | |
| | | | | DRAWING SIZE | THIRD ANGLE PROJECTION | | |
| | | | | C | | | |
| RELEASE STATUS | | P1 | RELEASE DATE | 16.12.2017 | 15:45:08 | | |



SFP ONE PIECE CAGE PRESS-FIT (0.090 LEGS)

PRODUCT CUSTOMER DRAWING

| | | |
|-----------------|-----------------|----------|
| SERIES | MATERIAL NUMBER | CUSTOMER |
| 74737 | 747370002 | |
| DOCUMENT NUMBER | DOC TYPE | DOC PART |
| 747370002 | PSD | ASY |
| SHEET NUMBER | 2 OF 4 | |

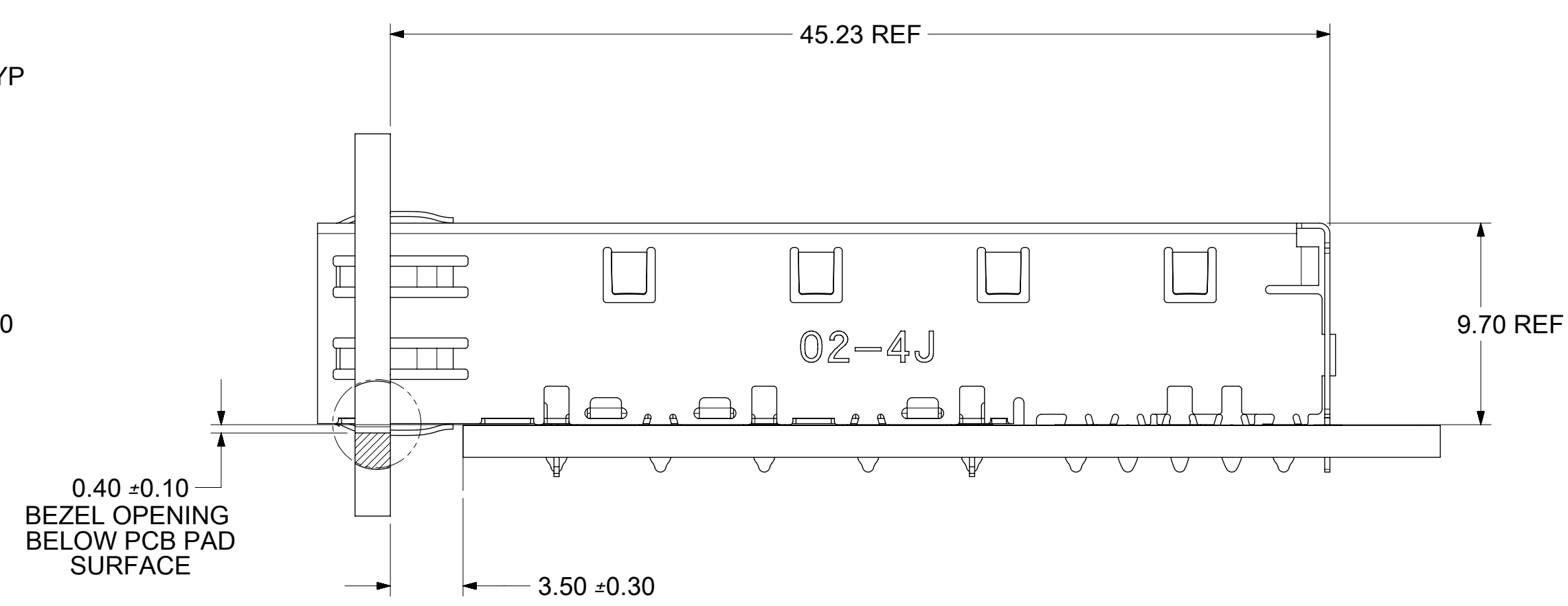
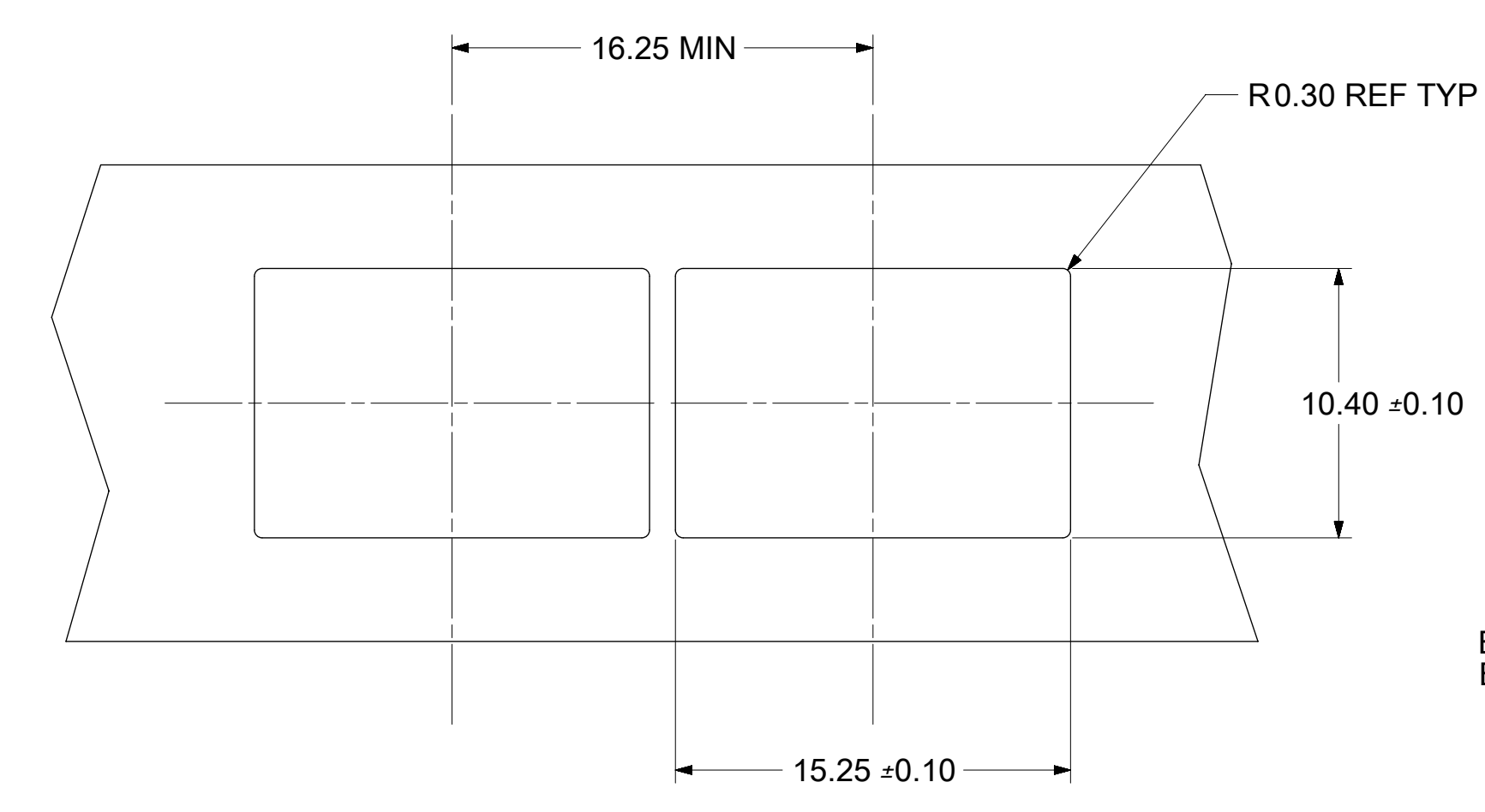

| | | | | | | | | | | | | | |
|-----------------|-------|---|---|---------------------------------------|--------------|-----------------|--|-----------|----------|-----|----------|----------|--------------|
| QUALITY SYMBOLS | | THIS DRAWING CONTAINS INFORMATION THAT IS PROPRIETARY TO MOLEX ELECTRONIC TECHNOLOGIES, LLC AND SHOULD NOT BE USED WITHOUT WRITTEN PERMISSION | | | | | | | | | | | |
| ▽ = 0 | ▽ = 0 | SEE REVISION TABLE | EC NO: 169609 DRWN: MKEMPEGOWDA CHKD: EWANG07 REV: APPR: RCHEN08 | GENERAL TOLERANCES (UNLESS SPECIFIED) | | DIMENSION UNITS | SCALE | | | | | | |
| ▽ = 0 | ▽ = 0 | | | ANGULAR TOL ± 1.0 ° | | mm | 4:1 | | | | | | |
| ▽ = 0 | ▽ = 0 | | | 4 PLACES ± | DRWN BY | DATE | MKEMPEGOWDA 2017/12/11 | | | | | | |
| ▼ = 0 | ▽ = 0 | | | 3 PLACES ± | CHKD BY | DATE | EWANG07 2017/12/15 | | | | | | |
| ▽ = 0 | ▽ = 0 | | | 2 PLACES ± 0.13 | APPR BY | DATE | RCHEN08 2017/12/16 | | | | | | |
| ⊠ = 0 | ■ = 0 | | | 1 PLACE ± 0.25 | DRAWING SIZE | | THIRD ANGLE PROJECTION | | | | | | |
| ▽ = 0 | ▽ = 0 | 0 PLACES ± | DRAFT WHERE APPLICABLE MUST REMAIN WITHIN DIMENSIONS | | C | | SERIES: 74737 MATERIAL NUMBER: 747370002 CUSTOMER: | | | | | | |
| RELEASE STATUS | | P1 | RELEASE DATE | 16.12.2017 | 15:45:08 | DOCUMENT NUMBER | | 747370002 | DOC TYPE | PSD | DOC PART | DOC PART | SHEET NUMBER |
| 12 | | 11 | | 10 | | 9 | | 8 | | 7 | | 6 | |
| 12 | | 11 | | 10 | | 9 | | 8 | | 7 | | 6 | |

| REV | DATE | DESCRIPTION |
|-----|------------|---|
| A | 2007/01/17 | INITIAL RELEASE |
| B | 2007/01/24 | UPDATED VIEWS |
| C | 2007/02/08 | ADDED NOTE 5 |
| D | 2007/03/06 | ADDED SHEETS 2 AND 3 |
| E | 2007/01/23 | UPDATED 2D VIEWS TO REFLECT CHG'S MADE TO EM-74737-004 REV E. |
| F | 2007/04/25 | [1] ADDED REV SHEET; [2] UPDATED REV NOTES A-D; [3] UPDATED DRAWING TO REFLECT CHG'S MADE TO EM-74737-002-ASSY REV D; [4] ON SHT1 ROTATED BTM_VIEW 180 DEGREES. |
| G | 2007/11/27 | [1] UPDATED VIEWS TO MATCH EM-74737-002-ASSY REV E. |
| H | 2014/12/02 | 1. ADDED "MM 3D MODEL: EM-74737-004-ASSY" ON LEFT TOP CORNER. [SHEET 1] 2. ADDED NOTE 6, 7, 8. [SHEET 1] 3. CHANGED NOTE5 TO "NO RoHS EXEMPTIONS". [SHEET 1] 4. REMOVED ALL INCH UNIT. [SHEET 1~3] |
| J | 2017/12/14 | REMASTERED FROM SD-74737-002 REV H TO 747370002 PSD ASY REV J SHEET 1: A12: CHANGED EG IN NOTE 8 FROM (E.G., 02-3J) TO (E.G., 02-4J) |

| | | | | | | | | | | | | | | | |
|-----------------|--------------------|---|------------|-------------------|------------|---------------|------------|--------------------|--|--------------|------------------------|--|--|--|--|
| QUALITY SYMBOLS | | THIS DRAWING CONTAINS INFORMATION THAT IS PROPRIETARY TO MOLEX ELECTRONIC TECHNOLOGIES, LLC AND SHOULD NOT BE USED WITHOUT WRITTEN PERMISSION | | | | | | | | | | | | | |
| ▽ = 0 | SEE REVISION TABLE | EC NO: 169609 | 2017/12/11 | DRWN: MKEMPEGOWDA | 2017/12/15 | CHKD: EWANG07 | 2017/12/16 | REV: APPR: RCHEN08 | GENERAL TOLERANCES (UNLESS SPECIFIED) | | DIMENSION UNITS | SCALE | molex SFP ONE PIECE CAGE PRESS-FIT (0.090 LEGS) | | |
| ▽ = 0 | | | | | | | | | ANGULAR TOL ± 1.0 ° | | mm | 1:1 | | | |
| ▽ = 0 | | | | | | | | | 4 PLACES ± | | DRWN BY | DATE | PRODUCT CUSTOMER DRAWING | | |
| ▽ = 0 | | | | | | | | | 3 PLACES ± | MKEMPEGOWDA | 2017/12/11 | | | | |
| ▽ = 0 | | | | | | | | | 2 PLACES ± 0.13 | CHKD BY | DATE | SERIES MATERIAL NUMBER CUSTOMER 74737 747370002 | | | |
| ▽ = 0 | | | | | | | | | 1 PLACE ± 0.25 | EWANG07 | 2017/12/15 | | | | |
| ▽ = 0 | | | | | | | | | 0 PLACES ± | APPR BY | DATE | DOCUMENT NUMBER DOC TYPE DOC PART SHEET NUMBER 747370002 PSD ASY 4 OF 4 | | | |
| ▽ = 0 | | | | | | | | | DRAFT WHERE APPLICABLE MUST REMAIN WITHIN DIMENSIONS | RCHEN08 | 2017/12/16 | | | | |
| ▽ = 0 | | | | | | | | | | DRAWING SIZE | THIRD ANGLE PROJECTION | | | | |
| ▽ = 0 | | | | | | | | | | C | | | | | |

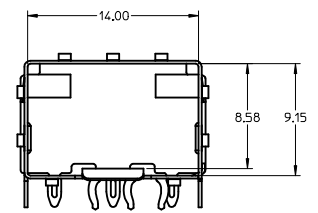
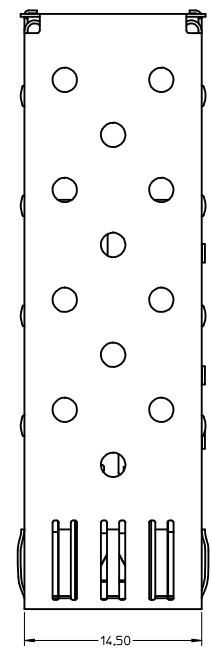
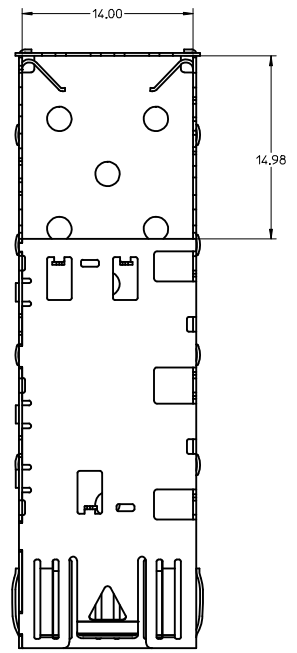

SPRING FINGER GASKET WITH TWO POINTS OF CONTACT. COMPLIES WITH (SFP) MSA BOARD AND BEZEL LOCATIONS.

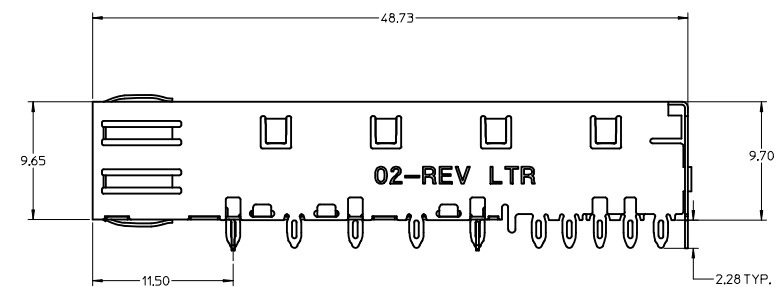
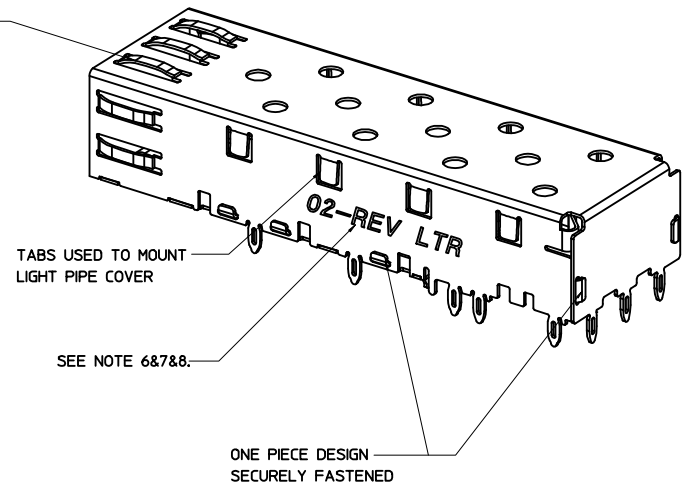

NOTES:

1. PRESS FIT LEGS, 2.28mm LONG.
1.57mm MINIMUM PCB THICKNESS.
2. THIS CAGE IS FOR SINGLE SIDED USE ONLY.
3. CAN BE USED WITH THE FOLLOWING LIGHT PIPE PART NUMBERS:
747260001 - LIGHT PIPE FROM BACK TO TOP
(REFER TO DOCUMENT SD-74726-001)
747260002 - LIGHT PIPE FROM SIDE TO TOP
(REFER TO DOCUMENT SD-74726-002)
4. MATERIAL: COPPER ALLOY
PLATING: PRE-PLATED WITH NICKEL
5. NO RoHS EXEMPTIONS.
6. REVISION LETTER IS FOLLOWING MOLEX 3D MODEL.
7. INSERT TO CHANGE ENGRAVING FOR LAST TWO DIGITS OF PART NUMBER OR 3D REVISION.
8. INSERT TO IDENTIFY ADDITIONAL TOOLING STARTING WITH TOOL #2 AS FOLLOWS:
LAST TWO DIGITS OF PART NUMBER, TOOL NUMBER AND REVISION LETTER
(E.G., 02-3J)

| | | | | | | | |
|---|--|--|---|--|------------------------------|------------------------|--|
| SEE REVISION TABLE IEC NO: CPG2015-2800 DRAWN/LUZO 2014/12/02 CHKD/SYANG16 2014/12/03 APPR/RCHE08 2014/12/22 | QUALITY SYMBOLS ∇=0 ∇=0 ∇=0 | GENERAL TOLERANCES (UNLESS SPECIFIED) mm INCH 4 PLACES ± --- ± --- 3 PLACES ± --- ± --- 2 PLACES ± 0.13 ± --- 1 PLACE ± 0.25 ± --- 0 PLACE ± ± | DIMENSION STYLE MM ONLY | SCALE 5:1 | DESIGN UNITS METRIC | THIRD ANGLE PROJECTION | |
| | DRAFT WHERE APPLICABLE MUST REMAIN WITHIN DIMENSIONS | | DRAWN BY DATE CCOX 2007/01/18 | TITLE SFP ONE PIECE CAGE PRESS-FIT (0.090 LEGS) | | | |
| | MATERIAL NO. 747370002 | | APPROVED BY DATE RMAHMOOD 2007/01/18 | | DOCUMENT NO. SD-74737-002 | | |
| | SIZE D | | THIS DRAWING CONTAINS INFORMATION THAT IS PROPRIETARY TO MOLEX INCORPORATED AND SHOULD NOT BE USED WITHOUT WRITTEN PERMISSION | | | | |

- 1. DATUM AND BASIC DIMENSIONS ESTABLISHED BY CUSTOMER.
- 2. PADS AND VIAS ARE CHASSIS GROUND.
- 3. HOLE LAYOUT SHOWN IS FOR SINGLE SIDED MOUNTING ONLY.
- 4. CONNECTOR PAD LAYOUT PER SFP MSA, WILL ACCOMMODATE MOLEX CONNECTOR SERIES 74441 OR EQUIVALENT.

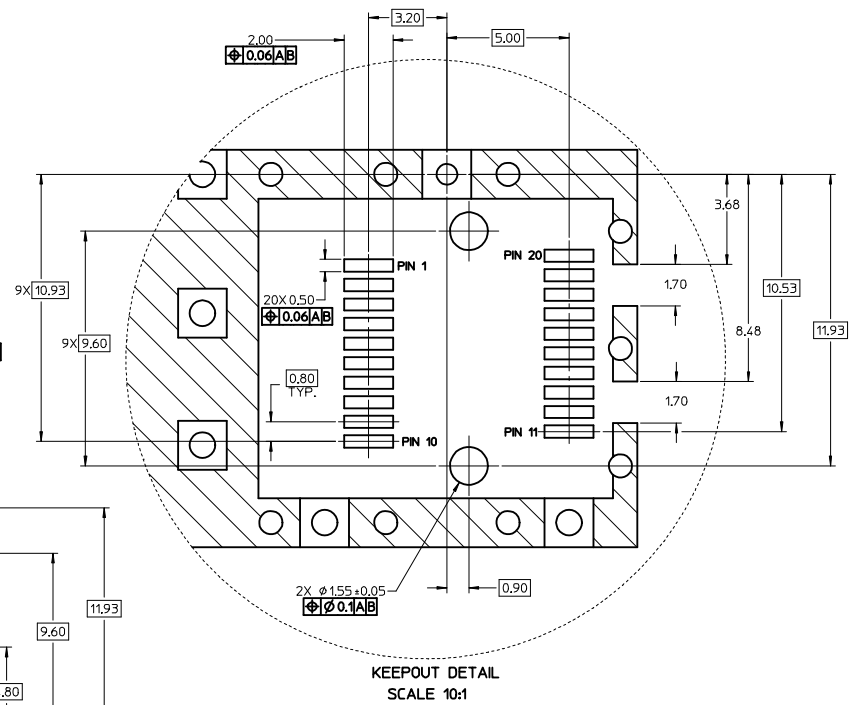
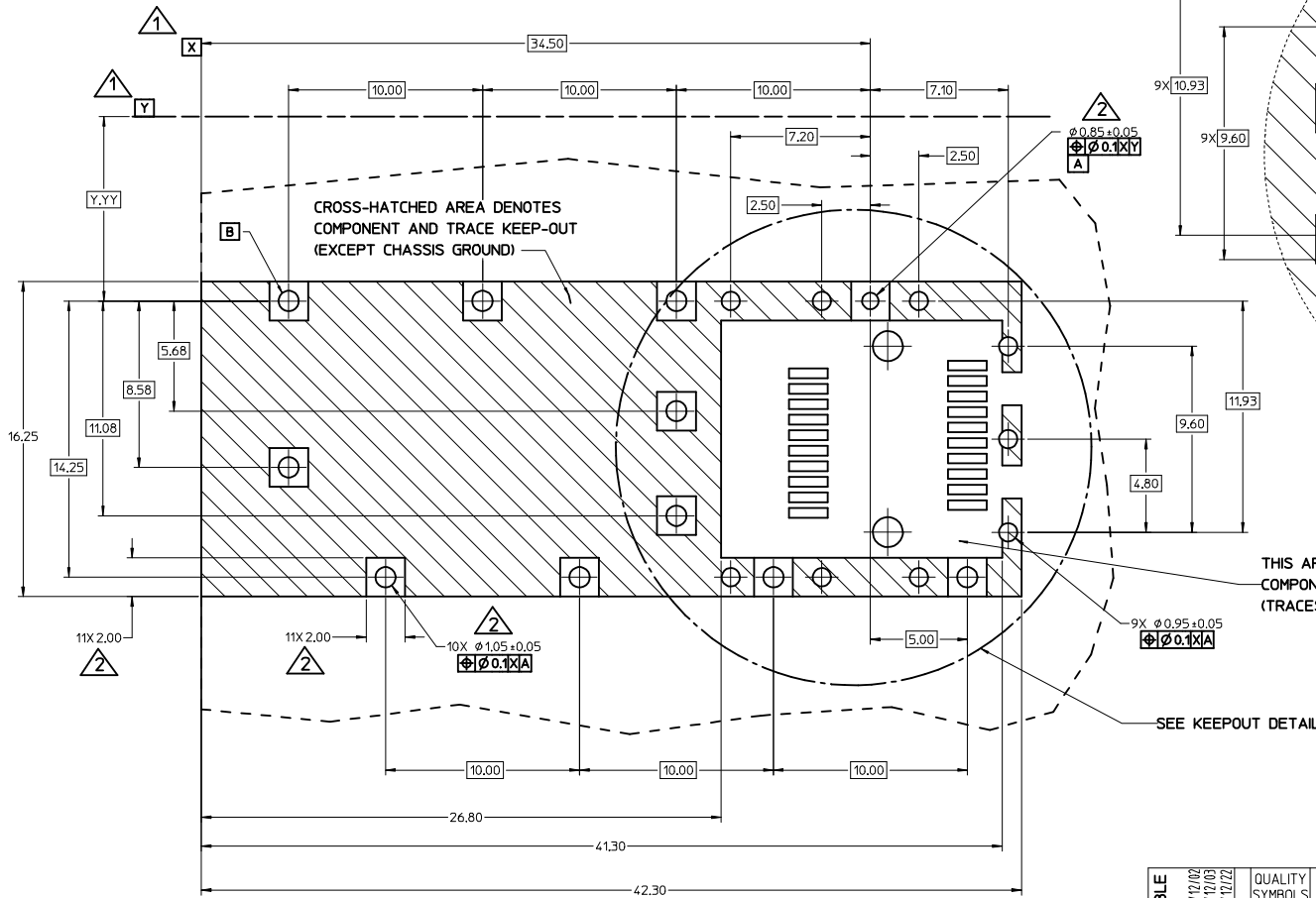

THIS AREA DENOTES
COMPONENT KEEP-OUT
(TRACES ALLOWED)

SEE KEEPOUT DETAIL

| | | | | | | |
|---|--|---------------------------------------|-----------------------|----------------------|------------------------|--|
| SEE REVISION TABLE IEC NO: CPG2015-2800 DRAWN BY: DRWNLU20 CHECKED BY: CHYKSYANG16 APPROVED BY: APPRRCHEUNG8 DATE: 2014/12/02 DATE: 2014/12/03 DATE: 2014/12/22 | QUALITY SYMBOLS | GENERAL TOLERANCES (UNLESS SPECIFIED) | DIMENSION STYLE | SCALE | DESIGN UNITS | THIRD ANGLE PROJECTION |
| | ▽=0 | mm | MM ONLY | 8:1 | METRIC | ☉ |
| | ▽=0 | INCH | 4 PLACES ± --- | DRAWN BY: CCOX | DATE: 2007/01/18 | TITLE: SFP ONE PIECE CAGE PRESS-FIT (0.090 LEGS) |
| | ▽=0 | ANGULAR ± 1 ° | 3 PLACES ± --- | CHECKED BY: RMAHMOOD | DATE: 2007/01/18 | 2 OF 4 |
| ▽=0 | DRAFT WHERE APPLICABLE MUST REMAIN WITHIN DIMENSIONS | 2 PLACES ± 0.13 | APPROVED BY: RMAHMOOD | DATE: 2007/01/18 | MATERIAL NO: 747370002 | DOCUMENT NO: SD-74737-002 |
| ▽=0 | | 1 PLACE ± 0.25 | | | | |
| | | 0 PLACE ± | | | | |

molex

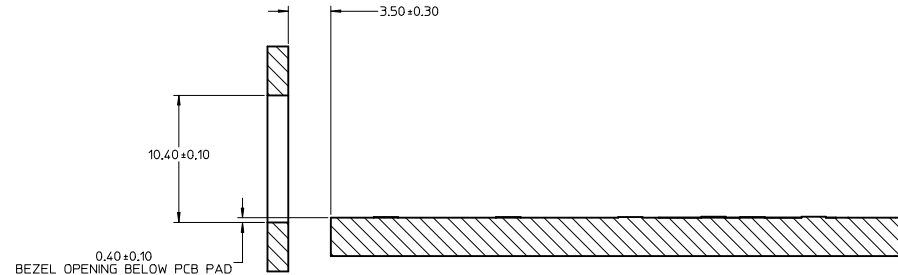
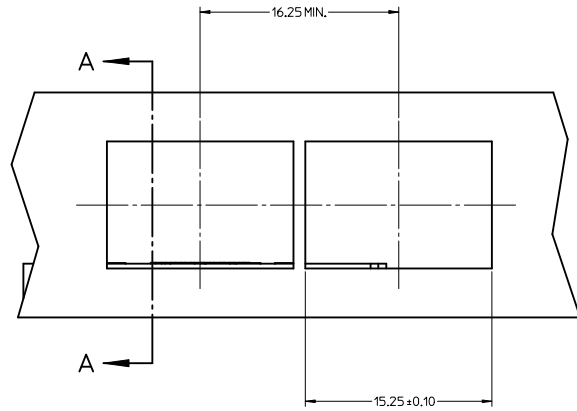
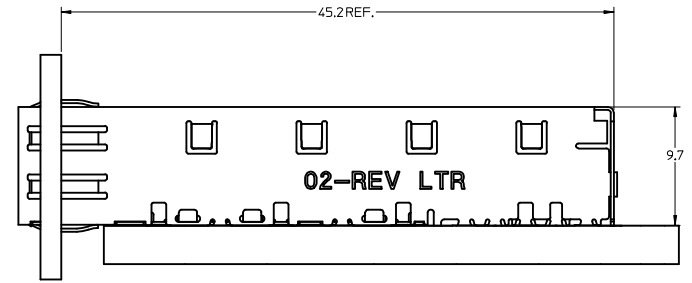

| SEE REVISION TABLE EC NO: CPG2015-2800 DRW: LUL20 2014/12/02 CHK: DSYANG 2014/12/03 APPR: RCHEN08 2014/12/22 | QUALITY SYMBOLS ∇=0 ∇=0 ∇=0 | GENERAL TOLERANCES (UNLESS SPECIFIED) <table border="1"> <thead> <tr> <th></th> <th>mm</th> <th>INCH</th> </tr> </thead> <tbody> <tr> <td>4 PLACES</td> <td>± 0.15</td> <td>± 0.005</td> </tr> <tr> <td>3 PLACES</td> <td>± 0.20</td> <td>± 0.008</td> </tr> <tr> <td>2 PLACES</td> <td>± 0.25</td> <td>± 0.010</td> </tr> <tr> <td>1 PLACE</td> <td>± 0.30</td> <td>± 0.012</td> </tr> <tr> <td>0 PLACE</td> <td>± 0.35</td> <td>± 0.014</td> </tr> </tbody> </table> | | mm | INCH | 4 PLACES | ± 0.15 | ± 0.005 | 3 PLACES | ± 0.20 | ± 0.008 | 2 PLACES | ± 0.25 | ± 0.010 | 1 PLACE | ± 0.30 | ± 0.012 | 0 PLACE | ± 0.35 | ± 0.014 | DIMENSION STYLE MM ONLY | SCALE 5:1 | DESIGN UNITS METRIC | THIRD ANGLE PROJECTION |
|---|--|---|--|---|---|----------|--------|---------|----------|--------|---------|----------|--------|---------|---------|--------|---------|---------|--------|---------|-----------------------------------|---------------------|-------------------------------|------------------------|
| | | mm | INCH | | | | | | | | | | | | | | | | | | | | | |
| | 4 PLACES | ± 0.15 | ± 0.005 | | | | | | | | | | | | | | | | | | | | | |
| | 3 PLACES | ± 0.20 | ± 0.008 | | | | | | | | | | | | | | | | | | | | | |
| 2 PLACES | ± 0.25 | ± 0.010 | | | | | | | | | | | | | | | | | | | | | | |
| 1 PLACE | ± 0.30 | ± 0.012 | | | | | | | | | | | | | | | | | | | | | | |
| 0 PLACE | ± 0.35 | ± 0.014 | | | | | | | | | | | | | | | | | | | | | | |
| | ANGULAR ± 1 ° DRAFT WHERE APPLICABLE MUST REMAIN WITHIN DIMENSIONS | DRAWN BY CCOX DATE 2007/01/18 | CHECKED BY RMAHMOOD DATE 2007/01/18 | APPROVED BY RMAHMOOD DATE 2007/01/18 | TITLE SFP ONE PIECE CAGE PRESS-FIT (0.090 LEGS) | | | | | | | | | | | | | | | | | | | |
| | | MATERIAL NO. 747370002 | DOCUMENT NO. SD-74737-002 | SHEET NO. 3 OF 4 | | | | | | | | | | | | | | | | | | | | |
| | | THIS DRAWING CONTAINS INFORMATION THAT IS PROPRIETARY TO MOLEX INCORPORATED AND SHOULD NOT BE USED WITHOUT WRITTEN PERMISSION | | | | | | | | | | | | | | | | | | | | | | |

| DATE | REV | REVISION TABLE |
|------------|-----|---|
| 2007/01/17 | A | INITIAL RELEASE |
| 2007/01/24 | B | UPDATED VIEWS |
| 2007/02/08 | C | ADDED NOTE 5 |
| 2007/03/06 | D | ADDED SHEETS 2 AND 3 |
| 2007/01/23 | E | UPDATED 2D VIEWS TO REFLECT CHG'S MADE TO EM-74737-002 REV E. |
| 2007/04/25 | F | [1] ADDED REV SHEET, [2] UPDATED REV NOTES A-D, [3] UPDATED DRAWING TO REFLECT CHG'S MADE TO EM-74737-002-ASSY REV D, [4] ON SHT1 ROTATED BTM_VIEW 180 DEGREES. |
| 2007/11/27 | G | [1] UPDATED VIEWS TO MATCH EM-74737-002-ASSY REV E. |
| 2014/12/02 | H | 1. ADDED *MM 3D MODEL: EM-74737-002-ASSY* ON LEFT TOP CORNER. [SHEET 1] 2. ADDED NOTE 6, 7, 8. [SHEET 1] 3. CHANGED NOTE5 TO *NO RoHS EXEMPTIONS*. [SHEET 1] 4. REMOVED ALL INCH UNIT. [SHEET 1~3] |
| | | |
| | | |

| | | | | | | |
|---|-----------------|--|---|---|------------------|------------------------|
| SEE REVISION TABLE IEC NO: CPG2015-2800 DRAWN BY: DRWNLJL20 2014/12/02 CHECKED BY: CHYKSYANG16 2014/12/03 APPROVED BY: APPRRCHE08 2014/12/22 REV: | QUALITY SYMBOLS | GENERAL TOLERANCES (UNLESS SPECIFIED) | DIMENSION STYLE | SCALE | DESIGN UNITS | THIRD ANGLE PROJECTION |
| | ▽=0 | 4 PLACES ± 0.13 | MM ONLY | 1:1 | METRIC | ☉ |
| | ▽=0 | 3 PLACES ± 0.25 | mm | | | |
| | ▽=0 | 2 PLACES ± 0.50 | INCH | | | |
| | ANGULAR ± 1° | DRAFT WHERE APPLICABLE MUST REMAIN WITHIN DIMENSIONS | DRAWN BY: CCOX DATE: 2007/01/18 | TITLE: SFP ONE PIECE CAGE PRESS-FIT (0.090 LEGS) | | |
| | | | CHECKED BY: RMAHMOOD DATE: 2007/01/18 |  | | |
| | | | APPROVED BY: RMAHMOOD DATE: 2007/01/18 | | | |
| | | | MATERIAL NO. 747370002 | DOCUMENT NO. SD-74737-002 | SHEET NO. 4 OF 4 | |
| | | | THIS DRAWING CONTAINS INFORMATION THAT IS PROPRIETARY TO MOLEX INCORPORATED AND SHOULD NOT BE USED WITHOUT WRITTEN PERMISSION | | | |