



Dynamic loudspeaker

18 × 13 × 4.2 mm

with spring

& waterproof

TR1813L042YN8

Revision

Date	Version	Status	Changes	Approver
2019/01/15	V0.1	Draft	First release	AX
2019/1/28	V0.2	Draft	Add PWB layout	AX
2019/02/12	V0.3	Draft	Add waterproof level and operation temp testing parameter	AX
2019/02/28	V0.4	Draft	Add temperature testing parameter	AX
2019/7/23	V0.5	Draft	Update F0 figure	AX
2019/7/29	V0.6	Draft	Update spring material	AX

1. Mechanical Characteristics

1.1. Mechanical Drawing

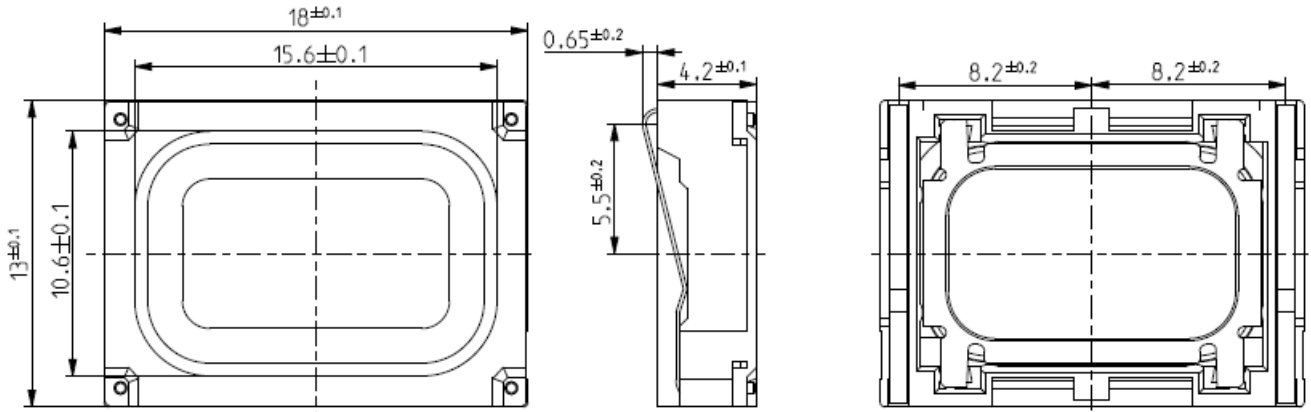

1.2. PWB layout

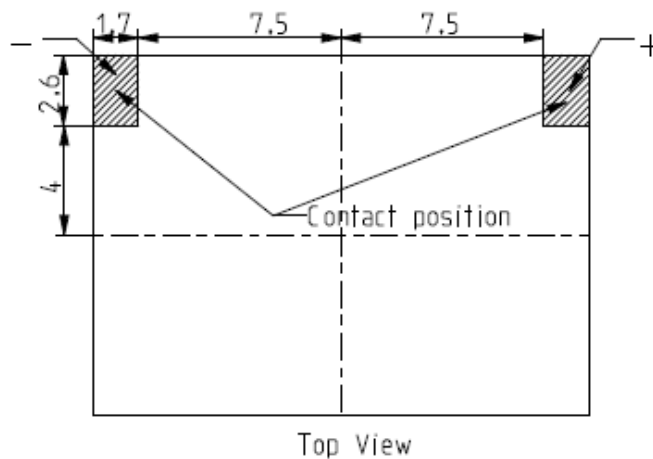

1.3. Material List

- | | | |
|----|-----------|-----------------------------|
| 1) | Basket | PPA+30%GF(black) |
| 2) | Cover | PPA+30%GF(black) |
| 3) | Membrane | Rubber |
| 4) | Pot | SPCC, Coating Ni |
| 5) | Magnet | Nd-Fe-B, Coating Zn |
| 6) | Top plate | SPCC, Coating Ni |
| 7) | Spring | SUS301-H, Coating Ni, Sn/Au |
| 8) | Dimension | 13x18x4.2mm |

2. Electro-Acoustic Characteristics

2.1. Frequency Response

Typical frequency response measured on baffle according to chapter 2.4
(distance $d=3.16\text{cm}$, with back cavity 1cm^3 at 2.366Vrms)

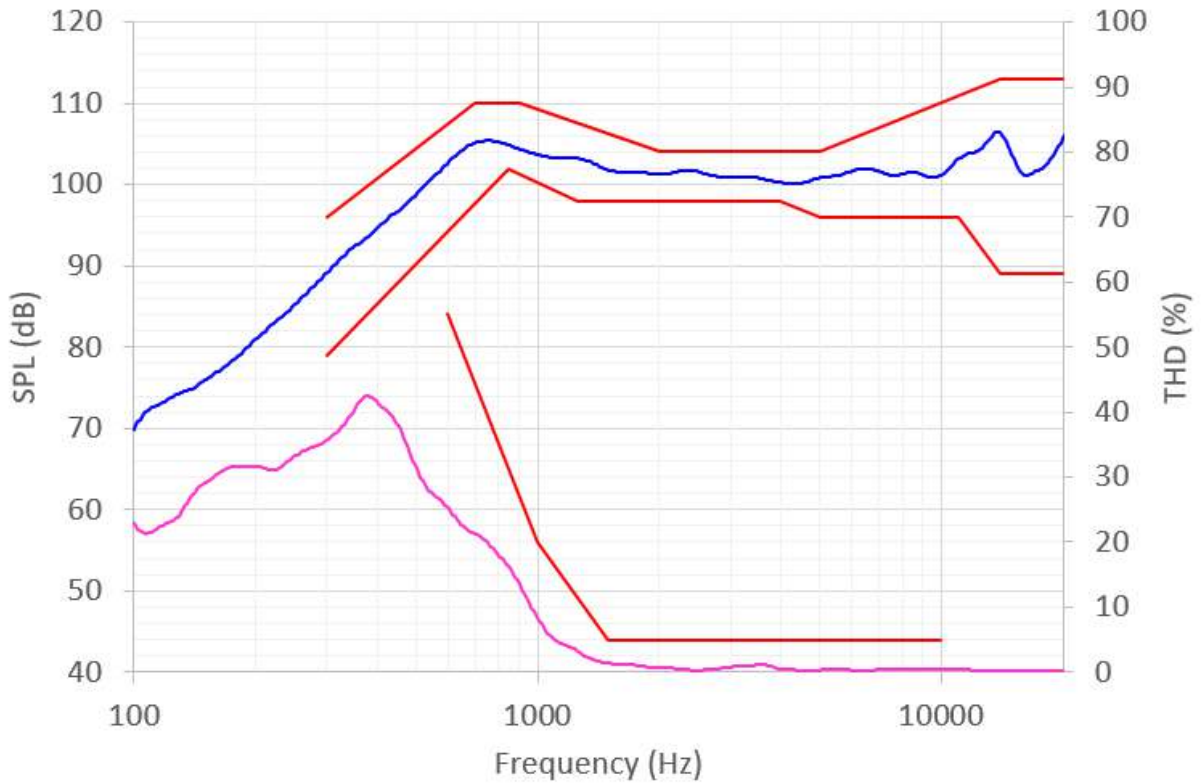

f(Hz)	SPL lower limit(dB)	f(Hz)	SPL upper limit(dB)	f(Hz)	THD upper limit(%)
300	79	300	96	600	55
850	102	700	110	1000	20
1250	98	900	110	1500	5
4000	98	2000	104	10000	5
5000	96	5000	104		
11000	96	14000	113		
14000	89	20000	113		
20000	89				

2.2. Electro-acoustic Parameters

Loudspeaker mounted in adapter according to 2.6 measured on baffle according to 2.4.

1. Rated impedance	Z:	8Ω
2. Voice coil resistance	R:	7.2Ω ± 10%
3. Resonance frequency with 1cc back cavity (measured at 1ccm 2.366V)	F ₀ :	700Hz ± 15%
4. Resonance frequency open back (measured at open back 0.566V)	F ₀ :	450Hz (typical)
5. Maximum usable excursion (measured at 1ccm 2.366V)	p-p:	1.0mm (typical)
6. Nominal characteristic sensitivity (calculated for 1W 1m) 1cc back cavity average in the frequency range:		73±2 dB 2k Hz to 5k Hz
7. Measured characteristic sensitivity (at 700mW in 3.16cm) 1cc back cavity average in the frequency range:		101.5±2dB 2k Hz to 5k Hz
8. THD according to chapter 2.1.		

All acoustic measurements at 23 ± 3°C

2.3. Power Handling

Loudspeaker mounted in lifetime test device (1ccm back cavity, open front)

1. MAX.SHORT TERM POWER (1sec. ON / 60sec. OFF) (pink noise, 2nd order high pass filtered, -3dB at 650Hz, crest factor 2)	1000mW (RMS)
2. MAX. CONTINUOUS POWER (96h) (pink noise, 2nd order high pass filtered, -3dB at 650Hz, crest factor 2)	700mW (RMS)

2.4. Measurement Setup (Acoustics)

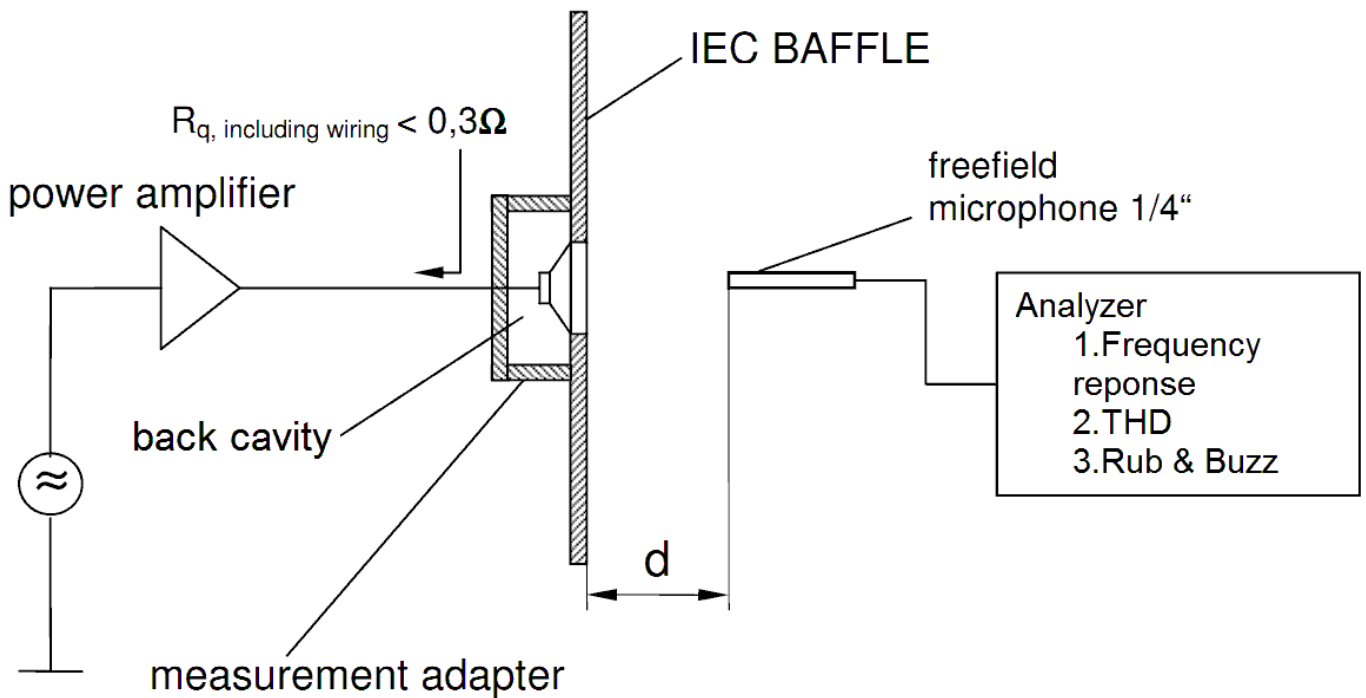

2.5. Measured Parameters

2.5.1. Sensitivity

SPL is expressed in dB ref $20\mu\text{Pa}$, computed according to IEC 268-5

Measurement set up according to chapter 2.4

This test is performed for 100% of products in the production line

2.5.2. Frequency Response

Frequency response is measured according to test set up in chapter 2.4 and checked against the tolerance window defined in chapter 2.1. This Test is performed for 100% of products in the production line.

2.5.3. Total Harmonic Distortion (THD)

Total harmonic distortion (THD) is measured according to IEC 268-5 (2nd to 5th harmonics) and test set up in chapter 2.4 and checked against the tolerance window defined in chapter 2.1. This test is performed for 100% of products in the production line.

2.5.4. Rub& Buzz

300-5000Hz at 2.366Vrms with 1cc back cavity will not result in any buzzing or extraneous sound.

2.6. Measurement Adapter

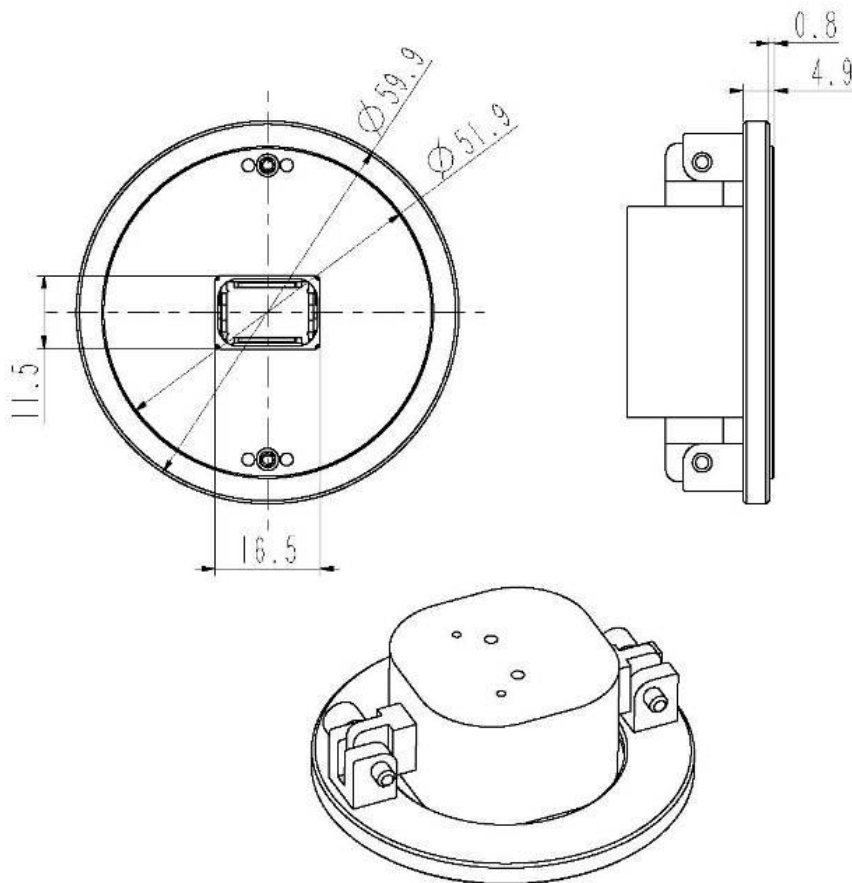

3. Environmental Tests

10pcs products for each environmental test.

Immediately after reliability test, products should be stored under room condition. Unless otherwise noted, the recovery period should be 2 hours at least before performance test.

All products after environmental test should meet the requirements specified in chapter 2.1 and 2.2 with 50% widened tolerance.

3.1. Low Temperature Storage Test

-40 ±2°C, duration 96h, 2 hours recovery time.

3.2. High Temperature Storage Test

+85±2°C, duration 96h, 2 hours recovery time.

3.3. High Temperature Operation Test

96h. +70°C, 1cc box Signal according to part 2 in chapter 2.3

3.4. Low Temperature Operation Test

96h. -20°C, 1cc box Signal according to part 2 in chapter 2.3.

3.5. Short Term Maximum Power Test

60 cycles. 1cc box Signal according to part 1 in Chapter 2.3.

3.6. Water-resistant Test

acc. IPx7, 1.0m water 30min. No ingress of water through the products allowed. Measurements after samples are dry.