

FOR -5 AND -6 ONLY

DETAIL F
2 PLC

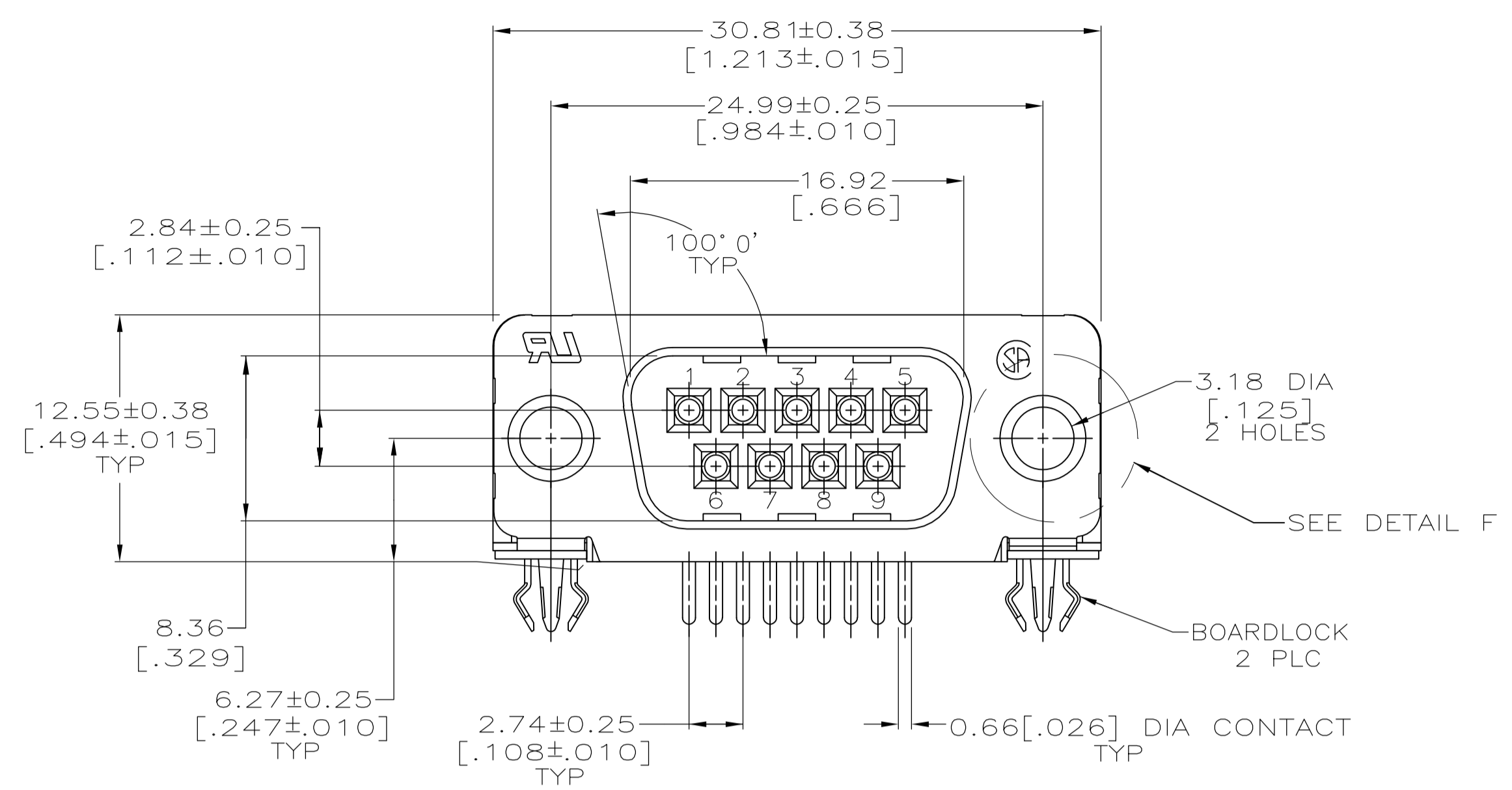

- ① HOUSING: NYLON OR POLYESTER, FLAME RETARDANT 94V-0 RATED, GLASS FILLED, BLACK
SHELLS: STEEL
CONTACTS: BRASS
BOARDLOCKS: COPPER ALLOY
EYELETS: BRASS
- ② SHELLS: 2.54μm[.000100] MIN TIN OVER 1.27μm[.000050] MIN COPPER.
EYELETS: 5.08μm[.000200] MIN TIN OVER COPPER FLASH.
INSERTS AND SCREWLOCKS: CLEAR CHROMATE.
CONTACTS AND BOARDLOCKS: SEE TABLE.
- ③ GOLD FLASH ON THE MATING SURFACES, 2.54μm[.000100] MIN TIN OR TIN-LEAD PLATE ON THE SOLDER END, 1.27μm[.000050] MIN NICKEL UNDERPLATE ON THE ENTIRE CONTACT.
- ④ 0.76μm[.000030] MIN GOLD PLATE ON THE MATING SURFACES, 2.54μm[.000100] MIN TIN OR TIN-LEAD PLATE ON THE SOLDER END, 1.27μm[.000050] MIN NICKEL UNDERPLATE ON THE ENTIRE CONTACT
-OR-
GOLD FLASH OVER PALLADIUM-NICKEL PLATE, 0.76μm[.000030] MIN TOTAL ON THE MATING SURFACES, 2.54μm[.000100] MIN TIN OR TIN-LEAD PLATE ON THE SOLDER END, 1.27μm[.000050] MIN NICKEL UNDERPLATE ON THE ENTIRE CONTACT.
- ⑤ 5.08μm[.000200] MIN TIN-LEAD OVER 1.27μm[.000050] MIN NICKEL.
- ⑥ 5.08μm[.000200] MIN TIN OVER 1.27μm[.000050] MIN NICKEL.
- ⑦ SUPERSEDED BY 747832-2.
- ⑧ SUPERSEDED BY 747832-6.
- ⑨ SUPERSEDED BY 747832-4.
- ⑩ OBSOLETE PART NUMBER.

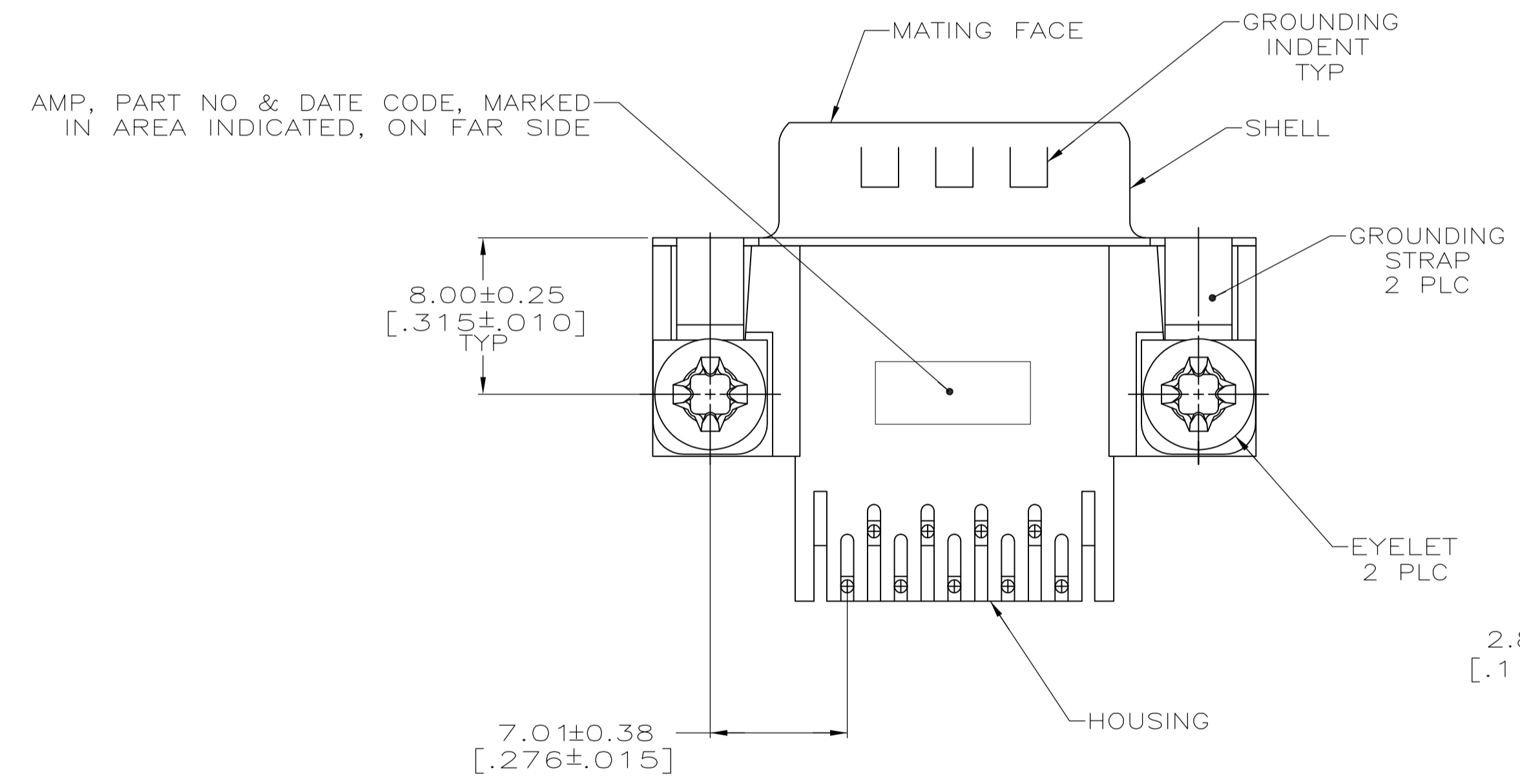

AMP, PART NO & DATE CODE, MARKED IN AREA INDICATED, ON FAR SIDE

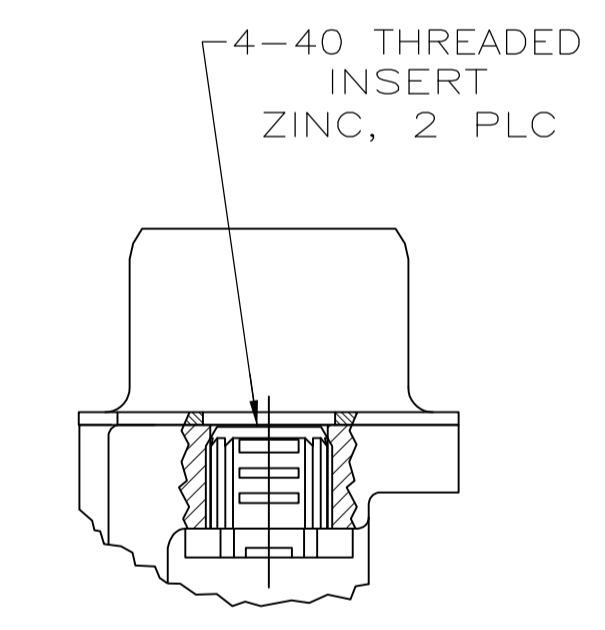
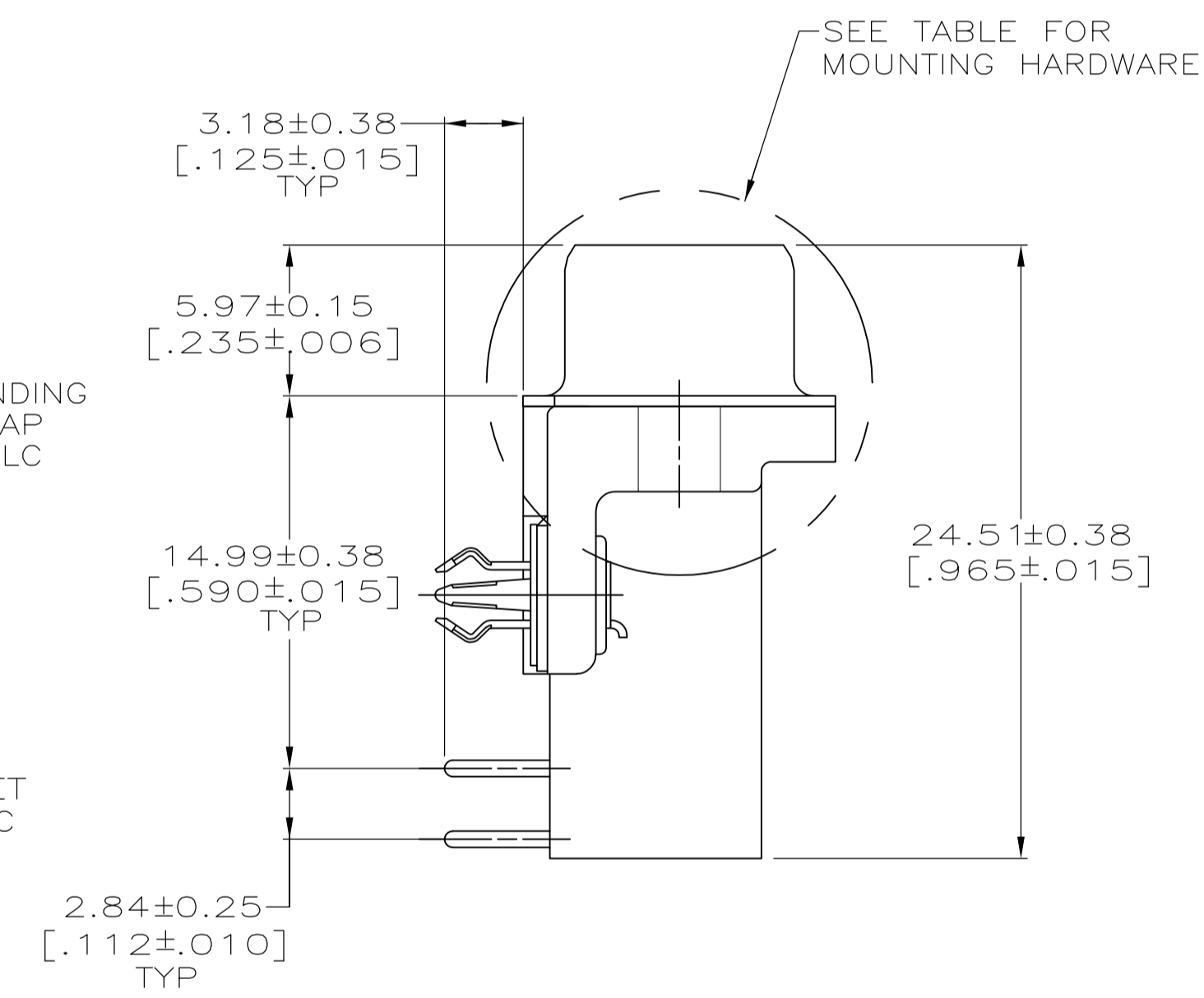

DETAIL D

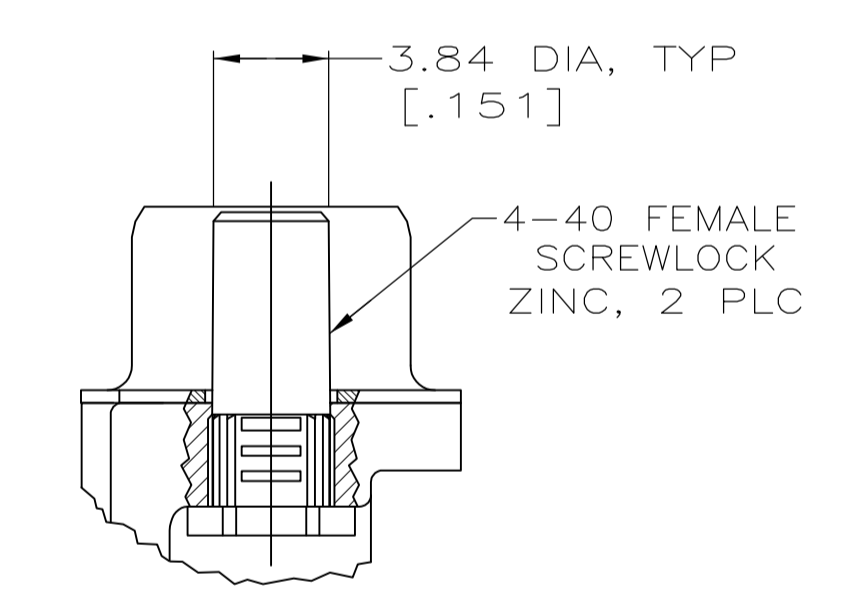

DETAIL E

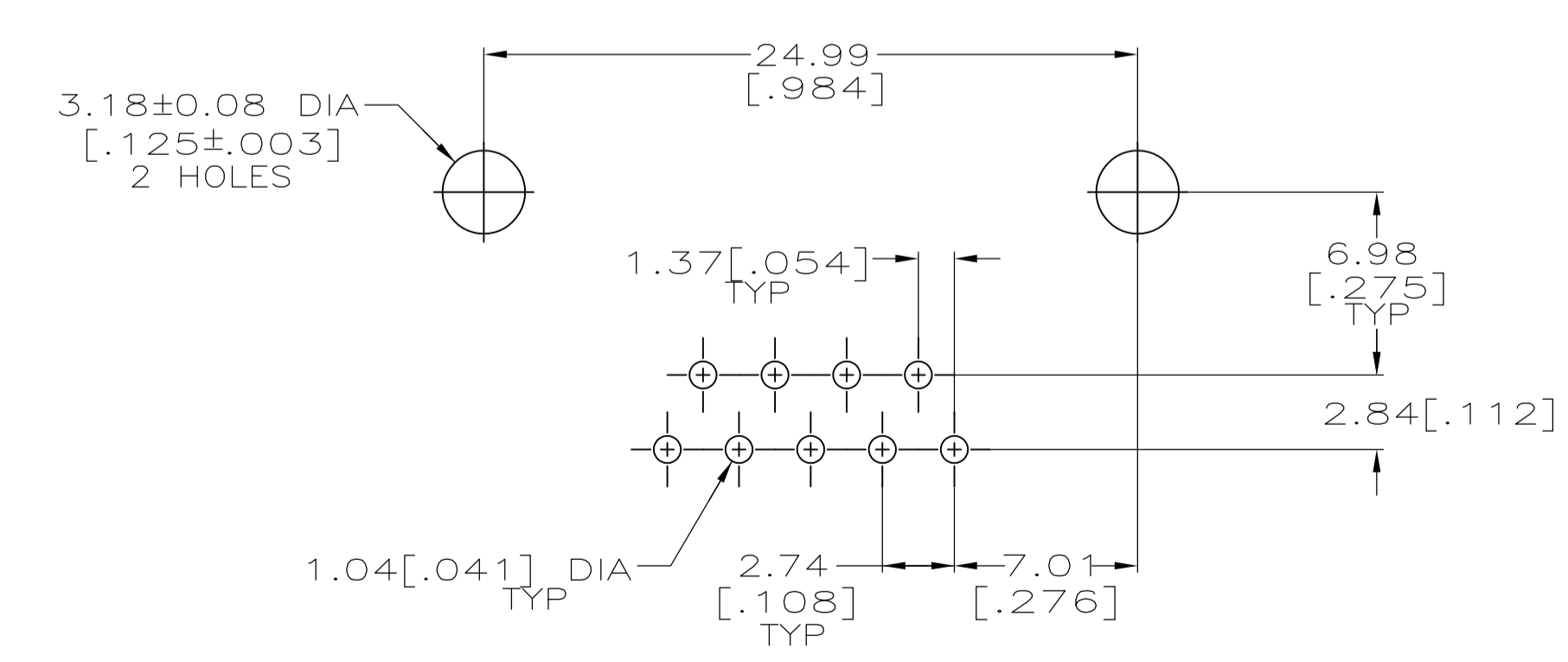

P.C. BOARD MOUNTING DIMENSIONS
P.C. BOARD THICKNESS: 1.57[.062]

SEE DETAIL D	⑥	④	6-747832-7
SEE DETAIL E	④	④	747832-6
SEE DETAIL D	④	⑧	747832-5
-	④	⑩	747832-4
-	④	⑩	747832-3
-	④	⑨	747832-2
-	④	⑦	747832-1
MOUNTING HARDWARE	BOARDLOCK FINISH	CONTACT FINISH	PART NUMBER

THIS DRAWING IS A CONTROLLED DOCUMENT. DIMENSIONING AND TOLERANCING PER ASME Y14.5M-2009.

DIMENSIONS: mm [INCHES]	TOLERANCES UNLESS OTHERWISE SPECIFIED: 0 PLC ± - 1 PLC ± - 2 PLC ± 0.13[.005] 3 PLC ± - 4 PLC ± - ANGLES ± °	DWG: W.G. LENKER 16 OCT 89 CHK: R. STONE 05 FEB 90 APVD: M.D. GALLOWAY 06 FEB 90 NAME: M.D. GALLOWAY PRODUCT SPEC: 108-40025 APPLICATION SPEC: 114-40010 WEIGHT: - CUSTOMER DRAWING	DIN: W.G. LENKER 16 OCT 89 CHK: R. STONE 05 FEB 90 APVD: M.D. GALLOWAY 06 FEB 90 NAME: M.D. GALLOWAY PRODUCT SPEC: 108-40025 APPLICATION SPEC: 114-40010 WEIGHT: - CUSTOMER DRAWING	STE TE Connectivity	PLUG ASSEMBLY, SIZE 1, 9 POSITION, RIGHT ANGLE, FRONT METAL SHELL, .590 SERIES, BOARDLOCKS, AMPLIMITE HD-20	SIZE: A1 CAGE CODE: 00779 DRAWING NO: 747832 SCALE: 4:1 SHEET: 1 OF 1 REV: U
----------------------------	--	--	--	------------------------	---	---