



MAX6877 Evaluation Kit

Evaluates: MAX6877

General Description

The MAX6877 evaluation kit (EV kit) is a complete, fully assembled and tested multivoltage power tracker/sequencer/supervisor controller circuit that demonstrates the capability of the MAX6877 controller. The MAX6877 ensures controlled voltage tracking or sequencing of up to three power-supply outputs during power-up, and controlled voltage during power-down. Voltage tracking ensures that all output voltages of the supplies rise or fall at the same rate while voltage sequencing turns on the outputs in order once the input voltages reach stability. The EV kit circuit features FAULT and PG/RST output signals to indicate fault and power-good conditions, respectively. The circuit's timing parameters and voltage thresholds are reconfigurable. The EV kit board is designed to handle up to 10A per channel.

Features

- ◆ Voltage Tracking of Up to Three Power Supplies During Power-Up/Power-Down
- ◆ Configurable Input Voltage Thresholds Set to 1.05V, 1.58V, and 2.93V
- ◆ Configurable Timing Parameters
- ◆ Output Signals for Circuit Monitoring
- ◆ Channel-Current Capability Up to 10A
- ◆ Fully Assembled and Tested

Ordering Information

PART	TEMP RANGE*	IC PACKAGE
MAX6877EVKIT	0°C to +70°C	24 TQFN

*EV Kit PC board temperature range only.

Component List

DESIGNATION	QTY	DESCRIPTION
C1–C4	4	0.1μF ±10%, 50V X7R ceramic capacitors (0603) Murata GRM188R71H104K or TDK C1608X7R1H104K
C5	1	1μF ±10%, 10V X7R ceramic capacitor (0603) TDK C1608X7R1A105K or Taiyo Yuden LMK107BJ105KA
C6	1	1200pF ±5%, 250V C0G ceramic capacitor (0805) TDK C2012C0G2E122J
C7	1	1000pF ±5%, 250V C0G ceramic capacitor (0805) TDK C2012C0G2E102J
C8	1	2200pF ±5%, 100V C0G ceramic capacitor (0805) TDK C2012C0G2A222J
C9, C10, C11	0	Not installed, ceramic capacitors (0603)
C12–C23	0	Not installed, ceramic capacitors (1210)
IN1, IN2, IN3, OUT1, OUT2, OUT3, GND (x 6)	12	Noninsulated banana jack connectors

DESIGNATION	QTY	DESCRIPTION
JU1	1	3-pin header
JU2–JU6	5	2-pin headers
N1, N2, N3	3	30A, ±20V n-channel MOSFETs (DPAK) Vishay SUD50N02-06
R1	1	80.6kΩ ±1% resistor (0603)
R2, R4, R6	3	16.5kΩ ±1% resistors (0603)
R3	1	35.7kΩ ±1% resistor (0603)
R5	1	18.2kΩ ±1% resistor (0603)
R7, R8	2	10kΩ ±5% resistors (0603)
R9	1	100kΩ ±5% resistor (0805)
U1	1	MAX6877ETG+ (24-pin TQFN-EP) (4mm x 4mm)
—	6	Shunts (JU1–JU6)
—	1	MAX6877 EV kit PC board

Component Suppliers

SUPPLIER	PHONE	WEBSITE
Murata	770-436-1300	www.murata.com
Taiyo Yuden	800-348-2496	www.t-yuden.com
TDK	847-803-6100	www.component.tdk.com
Vishay	—	www.vishay.com

Note: Indicate that you are using the MAX6877 when contacting these component suppliers.

MAX6877 Evaluation Kit

Quick Start

Required Equipment

Before you begin, the following equipment is needed:

- DC power supplies:
 - One 5V, 100mA (VCC)
 - One 1.2V, 10A (IN1)
 - One 1.8V, 10A (IN2)
 - One 3.3V, 10A (IN3)
- One four-channel oscilloscope
- Two voltmeters

Procedure

The MAX6877 EV kit is a fully assembled and tested surface-mount board. Follow the steps below for simple board operation. **Do not turn on the power supplies until all connections are completed.**

- 1) Verify that a shunt is installed across pins 1 and 2 of jumper JU1 (U1 enabled).
- 2) Verify that shunts are not installed across jumpers JU2 (autoretry mode enabled) and JU4 (MARGIN disabled for normal operation).
- 3) Verify that shunts are installed across jumpers JU3 (tracking mode enabled), JU5 (PG/RST logic-high equals VCC), and JU6 (FAULT logic-high equals VCC).
- 4) Connect the positive terminal of the 5V power supply to the VCC pad. Connect the ground terminal of this power supply to the GND pad.
- 5) Connect the positive terminal of the 1.2V power supply to the IN1 banana jack. Connect the ground terminal of this power supply to the GND banana jack.
- 6) Connect the positive terminal of the 1.8V power supply to the IN2 banana jack. Connect the ground terminal of this power supply to the GND banana jack.
- 7) Connect the positive terminal of the 3.3V power supply to the IN3 banana jack. Connect the ground terminal of this power supply to the GND banana jack.
- 8) Connect voltmeters or an oscilloscope to the FAULT and PG/RST pads to capture output signals.
- 9) Connect an oscilloscope to the OUT1, OUT2, and OUT3 pads to observe voltage tracking during power-up and power-down.
- 10) Turn on the VCC power supply.
- 11) Turn on the IN1, IN2, and IN3 power supplies.
- 12) Observe the voltage tracking operation on the oscilloscope.
- 13) Verify that OUT1, OUT2, and OUT3 equal 1.2V, 1.8V, and 3.3V, respectively.
- 14) The EV kit is ready for further testing.

Detailed Description

The MAX6877 EV kit circuit provides tracking/sequencing/supervisor monitoring for up to three power supplies during power-up and power-down using the MAX6877 controller. The controller ensures controlled output-voltage tracking within a specified range or sequence in the proper order after the system power supplies reach voltage stability. The MAX6877 generates all required voltages and timing characteristics to control up to three external n-channel MOSFETs for the OUT1, OUT2, and OUT3 output voltages. All three voltage thresholds are set with external resistors and all timing parameters are set with external capacitors.

The EV kit circuit's undervoltage thresholds are set to 1.05V, 1.58V, and 2.93V (typ). When all the input voltages exceed these thresholds for the t_{DELAY} period of 800 μ s, the controller turns on the external n-channel MOSFETs in either sequence or tracking mode to enable the system OUT1, OUT2, and OUT3 outputs. During voltage-tracking mode, the MOSFETs are turned on slowly to control the slew rate of each of the output voltages. The voltage at each output OUT_n is dynamically forced to track within 125mV of an internal reference ramp voltage. If any of the OUT_n voltages fail to track within 250mV from the reference ramp within the t_{FAULT} period of 219ms, the FAULT output signal is asserted low and the outputs are powered off. In sequence mode, the outputs are turned on independently one at a time: OUT1 first, OUT2 second, and OUT3 last. The PG/RST output signal is asserted high once the output voltages exceed their respective voltage thresholds for a 1300 μ s ($t_{TIMEOUT}$) period.

Output Slew-Rate Control

The MAX6877 slew pin requires a capacitor to set the internal reference ramp-voltage slew rate for the power-up/-down tracking phase, the t_{FAULT} time period, and the t_{RETRY} time period. Capacitor C7 (1000pF) connected to the SLEW pin sets the reference ramp-voltage slew rate, the t_{FAULT} time period, and the t_{RETRY} time period to 93.5V/s, 219ms, and 3.5s, respectively. Replace capacitor C7 with a different value to adjust the three timing parameters. Use the following equations to calculate the new timing parameter values when replacing capacitor C7:

MAX6877 Evaluation Kit

Evaluates: MAX6877

$$\text{Slew rate} = \frac{9.35 \times 10^{-8}}{C7}$$

$$t_{\text{FAULT}} = 2.191 \times 10^8 \times C7$$

$$t_{\text{RETRY}} = 3.506 \times 10^9 \times C7$$

where, C7 is in Farads, slew rate is in V/s, and t_{FAULT} and t_{RETRY} are in seconds.

Delay Control

The MAX6877 DELAY pin requires a capacitor to set the t_{DELAY} period before tracking or sequencing operation is enabled. Capacitor C6 (1200pF) connected to the DELAY pin sets the t_{DELAY} period to 800 μ s. Replace capacitor C6 with a different capacitor value to adjust the t_{DELAY} period or remove the capacitor to set the t_{DELAY} period to 200 μ s. Use the following equation to calculate the new capacitor value when adjusting the t_{DELAY} period:

$$t_{\text{DELAY}} = 200\mu\text{s} + (500\text{k}\Omega \times C6)$$

where, C6 is in Farads, and t_{DELAY} is in seconds.

Timeout Control

The MAX6877 TIMEOUT pin requires a capacitor to set the t_{TIMEOUT} period, where all the output voltages must have exceeded their respective thresholds, before PG/RST output is pulled high. Capacitor C8 (2200pF) connected to the TIMEOUT pin sets the t_{TIMEOUT} period to 1300 μ s. Replace capacitor C8 with a different capacitor value to adjust the t_{TIMEOUT} period, or remove capacitor C8 to set the t_{TIMEOUT} period to 200 μ s. Use the following equation to calculate the new capacitor value when adjusting the t_{TIMEOUT} period:

$$t_{\text{TIMEOUT}} = 200\mu\text{s} + (500\text{k}\Omega \times C8)$$

where, C8 is in Farads, and t_{TIMEOUT} is in seconds.

Input Power

The MAX6877 EV kit requires a 2.7V to 5.5V input voltage connected to VCC, IN1, IN2, or IN3 for normal operation. The highest input voltage source at any of these four inputs supplies power to the MAX6877 controller. A 2.7V to 5.5V power supply connected to VCC allows the user to reconfigure the IN1, IN2, and IN3 input thresholds below 2.7V and still maintain proper circuit operation.

Input Voltages

Once the MAX6877 controller is properly powered, the controller holds the GATE_ voltage low to keep MOSFETs N1, N2, and N3 off until the voltages at the three inputs (IN1, IN2, and IN3) exceed the input thresholds for a period of t_{DELAY} . After this condition is

satisfied, the controller ramps up the GATE_ pin voltages to start a tracking or sequence operation. The EV kit input voltage thresholds for IN1, IN2, and IN3 are configured with external resistors to 1.05V, 1.58V, and 2.93V, respectively. If any of the input voltages fall below its respective threshold, the controller immediately turns off all the outputs. The IN1, IN2, and IN3 input thresholds can be reconfigured by replacing the corresponding feedback resistors indicated in Table 1. Refer to the *Undervoltage Lockout Threshold Inputs* section in the MAX6877 data sheet to calculate the new resistor values when reconfiguring the EV kit input thresholds.

Tracking or sequencing control of any one of the channels can be disabled by connecting the IN_ input pad to ground and connecting a source greater than 0.5V to the corresponding SET_ pad. The IN1, IN2, IN3, OUT1, OUT2, OUT3, and their respective GND (ground) banana jacks should be used when evaluating the EV kit with currents greater than 1A.

Table 1. Input Threshold Setting

SOURCE	THRESHOLD (V)	FEEDBACK
IN1	1.05	R5, R6
IN2	1.58	R3, R4
IN3	2.93	R1, R2

Logic-Enabled Input

The MAX6788 controller features input pin EN/UV, which enables or disables the controller. Disabling the controller initiates a power-down tracking operation. Once the power-down tracking operation is complete, the controller holds the GATE_ pin voltage low to turn off MOSFETs N1, N2, and N3 and prevents current flow to the outputs OUT1, OUT2, and OUT3. The EN/UV pin can be configured using MAX6877 EV kit jumper JU1. See Table 2 for jumper JU1 settings.

Table 2. Jumper JU1 Configuration (EN/UV)

SHUNT POSITION	EN/UV PIN	EV KIT FUNCTION
1-2	Connected to ABP	U1 controller enabled
2-3	Connected to GND	U1 controller disabled/initiate power-down tracking operation
Not Installed	Connected to EN/UV Pad	External controller enables or disables U1

MAX6877 Evaluation Kit

Autoretry/Latchoff Modes

The MAX6877 controller features a $\overline{\text{LTCH/RTR}}$ input pin to set the controller in autoretry or latch-off mode. In autoretry mode, the controller waits for 3.5s (t_{RETRY}) after a fault condition before automatically restarting a power-up tracking or sequence operation. During the t_{RETRY} period, MOSFETs N1, N2, and N3 are turned off and the $\overline{\text{FAULT}}$ is asserted low. An autoretry operation requires that all the OUT_n voltages fall below 142mV (typ).

In latch-off mode, MOSFETs N1, N2, and N3 are latched off, and the $\overline{\text{FAULT}}$ output is asserted low once a fault condition is detected. To unlatch the MOSFETs and the $\overline{\text{FAULT}}$ output, clear the fault condition and then disable and enable (JU1) the controller or cycle the power supplies at VCC, IN1, IN2, and IN3 on and off.

The autoretry or latch modes can be set by configuring jumper JU2 on the EV kit board. See Table 3 for jumper JU2 configurations.

Table 3. Jumper JU2 Configuration (LTCH/RTR)

SHUNT POSITION	$\overline{\text{LTCH/RTR}}$ PIN	EV KIT FUNCTION
Installed	Connected to GND	Latch-off mode
Not Installed	Internally connected to ABP	Autoretry mode

Tracking/Sequence Modes

The MAX6877 controller features a $\overline{\text{TRK/SEQ}}$ input pin to set the controller in tracking or sequence mode. The $\overline{\text{TRK/SEQ}}$ pin can be configured by using the jumper JU3 on the EV kit board. See Table 4 for jumper JU3 settings.

Table 4. Jumper JU3 Configuration (TRK/SEQ)

SHUNT POSITION	$\overline{\text{TRK/SEQ}}$ PIN	EV KIT FUNCTION
Installed	Connected to GND	Tracking mode
Not Installed	Internally connected to ABP	Sequence mode

Tracking Mode

The MAX6877 controller initiates a tracking operation after the controller has been powered and all three IN_n inputs have exceeded their respective thresholds for t_{DELAY} . During tracking operation, the MAX6877 slowly

turns on the MOSFETs and monitors the voltages at the OUT_n outputs. The rising voltage at the outputs is compared with the internal reference slew-rate voltage ramp to ensure that the OUT_n voltages stay within the $\pm 250\text{mV}$ differential window. If, for any reason, any OUT_n voltages fail to track within the $\pm 250\text{mV}$ of the reference ramp, the $\overline{\text{FAULT}}$ output is asserted low, the power-up/tracking operation is terminated, and all the outputs are quickly powered off. If an OUT_n voltage is less than the reference ramp voltage by more than 125mV, the controller stops the reference ramp voltage from rising until the slow OUT_n voltage catches up.

Sequence Mode

The MAX6877 controller initiates a sequence operation after the controller has been powered and all three IN_n inputs have exceeded their respective thresholds for t_{DELAY} . In sequence mode, the outputs are turned on sequentially with a controlled slew rate: OUT_1 first, OUT_2 second, and OUT_3 last. Once the outputs exceed the $V_{\text{TH_PG}}$ threshold with respect to the input for t_{TIMEOUT} , the $\overline{\text{PG/RST}}$ is asserted high. If there is a fault condition during the power-up sequence operation before $\overline{\text{PG/RST}}$ is asserted high, all the outputs are turned off. During the power-down operation, all the outputs are turned off simultaneously, tracking each other.

Margin Input

The MAX6877 controller features a $\overline{\text{MARGIN}}$ input pin to disable monitoring functions during normal operation. Disabling the monitoring functions allows the user to vary the IN_n input supplies below their programmed thresholds without causing signal changes at the $\overline{\text{PG/RST}}$ and $\overline{\text{FAULT}}$ outputs. Install a shunt on jumper JU4 to disable all monitoring functions before varying the IN_n supplies to prevent monitoring alerts or faults.

The $\overline{\text{MARGIN}}$ pin can be configured using jumper JU4 on the EV kit board. See Table 5 for jumper JU4 settings.

Table 5. Jumper JU4 Configuration (MARGIN)

SHUNT POSITION	$\overline{\text{MARGIN}}$ PIN	EV KIT FUNCTION
Installed	Connected to GND	Margin mode enabled, monitoring functions disabled
Not Installed	Internally connected to ABP	Margin mode disabled, normal operation

MAX6877 Evaluation Kit

Evaluates: MAX6877

Logic Outputs

The MAX6877 EV kit features two output signals for circuit monitoring. The $\overline{\text{PG/RST}}$ output is asserted high when all the outputs OUT_n exceed their respective IN_n reference thresholds for the selected timeout period, t_{TIMEOUT} . The $\overline{\text{FAULT}}$ output is asserted low when the power-up phase is not completed within the fault period t_{FAULT} or if the OUT_n voltages fail to track properly.

When the $\overline{\text{PG/RST}}$ and $\overline{\text{FAULT}}$ outputs are asserted high, they are pulled to VCC through resistors R7 and R8 when shunts are installed across jumper JU5 and JU6, respectively. See Table 6 and Table 7 for jumper JU5 and JU6 configuration. $\overline{\text{PG/RST}}$ and $\overline{\text{FAULT}}$ outputs are disabled if shunts are not installed across jumpers JU5 and JU6. Connect a voltage source to pin 2 of jumpers JU5 and JU6 to set a different logic-high voltage level.

Table 6. Jumper JU5 Configuration

SHUNT POSITION	EV KIT FUNCTION
Installed	$\overline{\text{PG/RST}}$ pullup resistor R7 connected to VCC
Not Installed	Pullup resistor R7 not connected, connect a pullup voltage source to pin 2 of jumper JU5

Table 7. Jumper JU6 Configuration

SHUNT POSITION	EV KIT FUNCTION
Installed	$\overline{\text{FAULT}}$ pullup resistor R8 connected to VCC
Not Installed	Pullup resistor R8 not connected, connect a pullup voltage source to pin 2 of jumper JU6

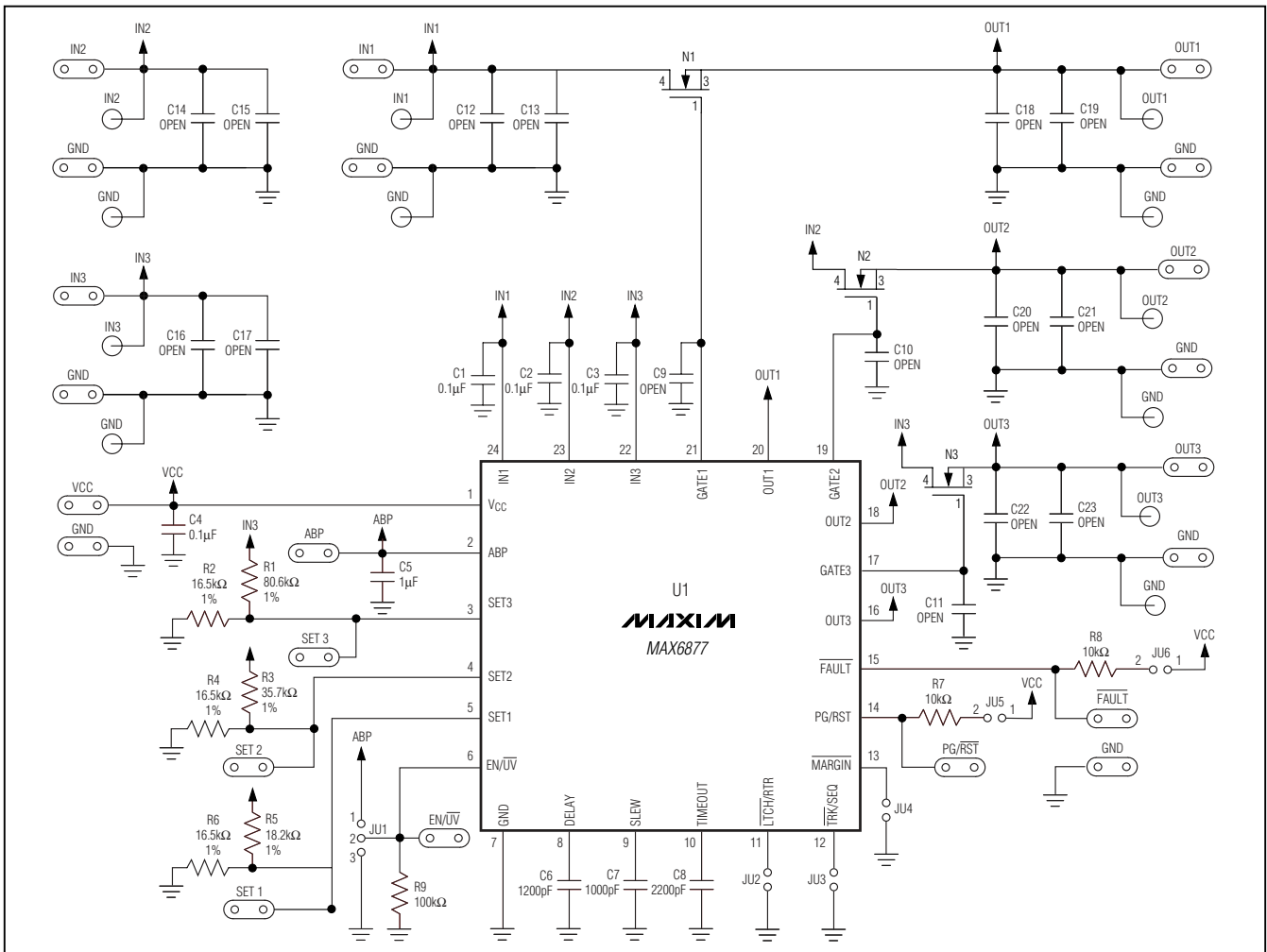

Figure 1. MAX6877 EV Kit Schematic

MAX6877 Evaluation Kit

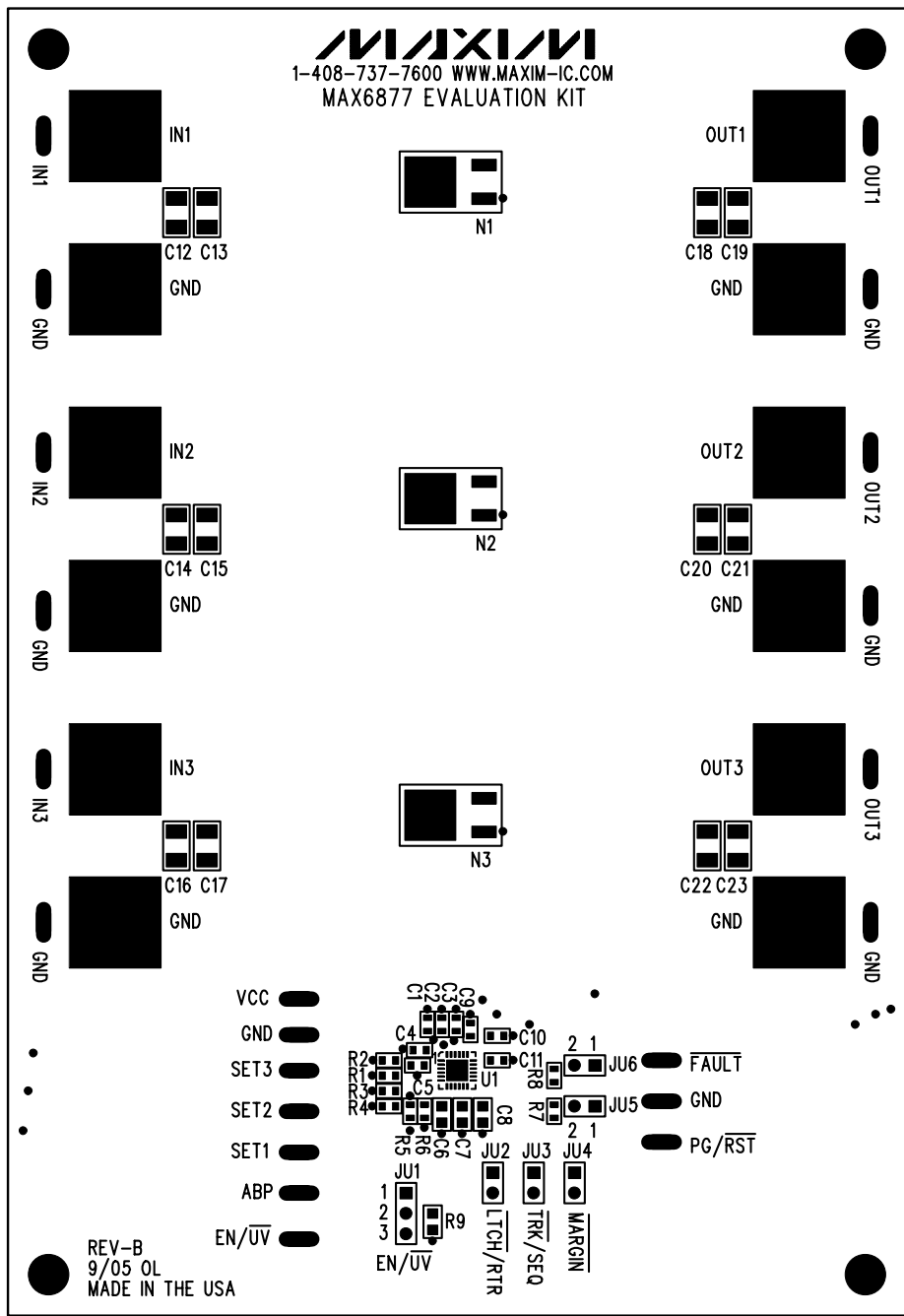

Figure 2. MAX6877 EV Kit Component Placement Guide—Component Side

MAX6877 Evaluation Kit

Evaluates: MAX6877

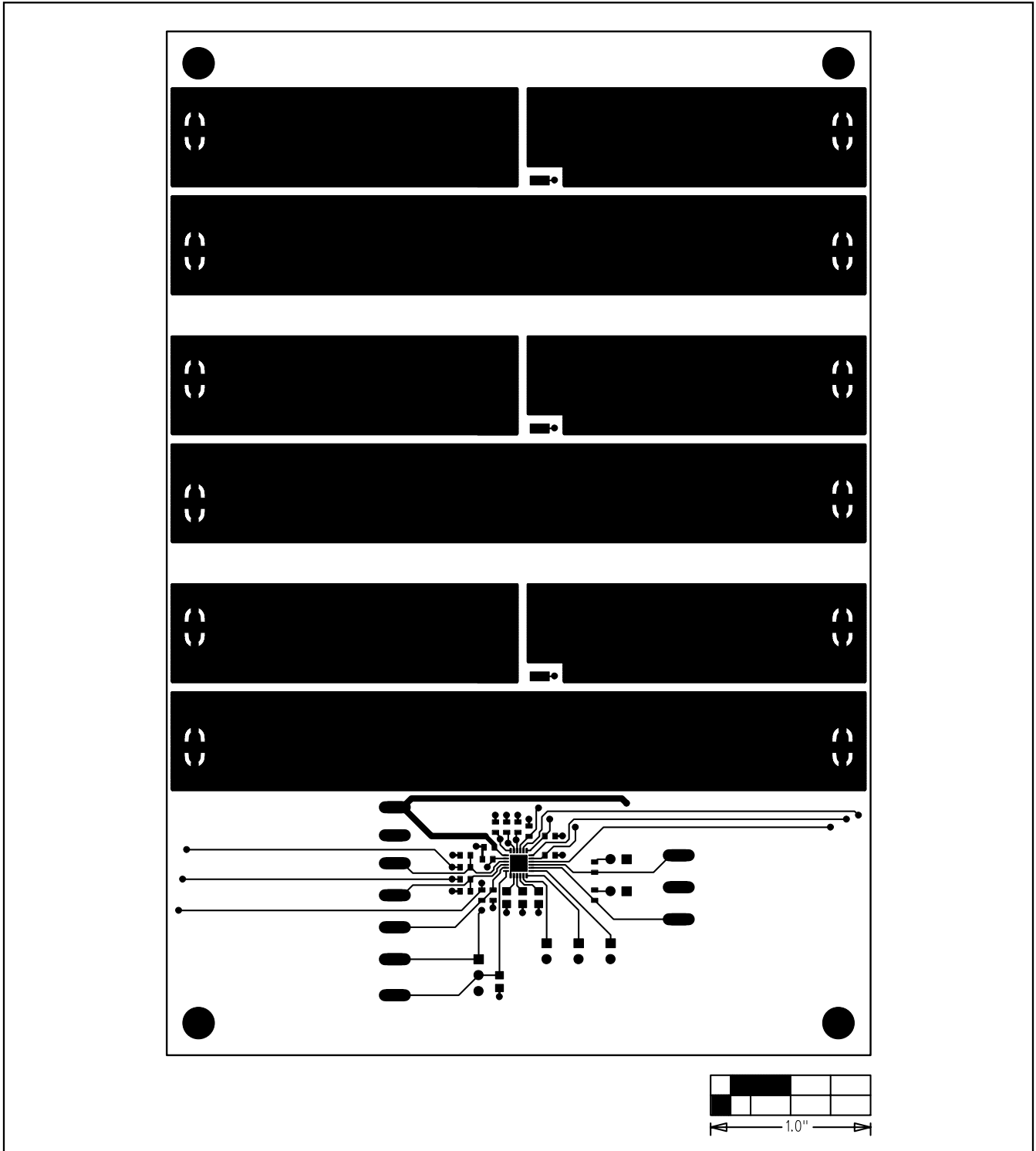

Figure 3. MAX6877 EV Kit PC Board Layout—Component Layer

MAX6877 Evaluation Kit

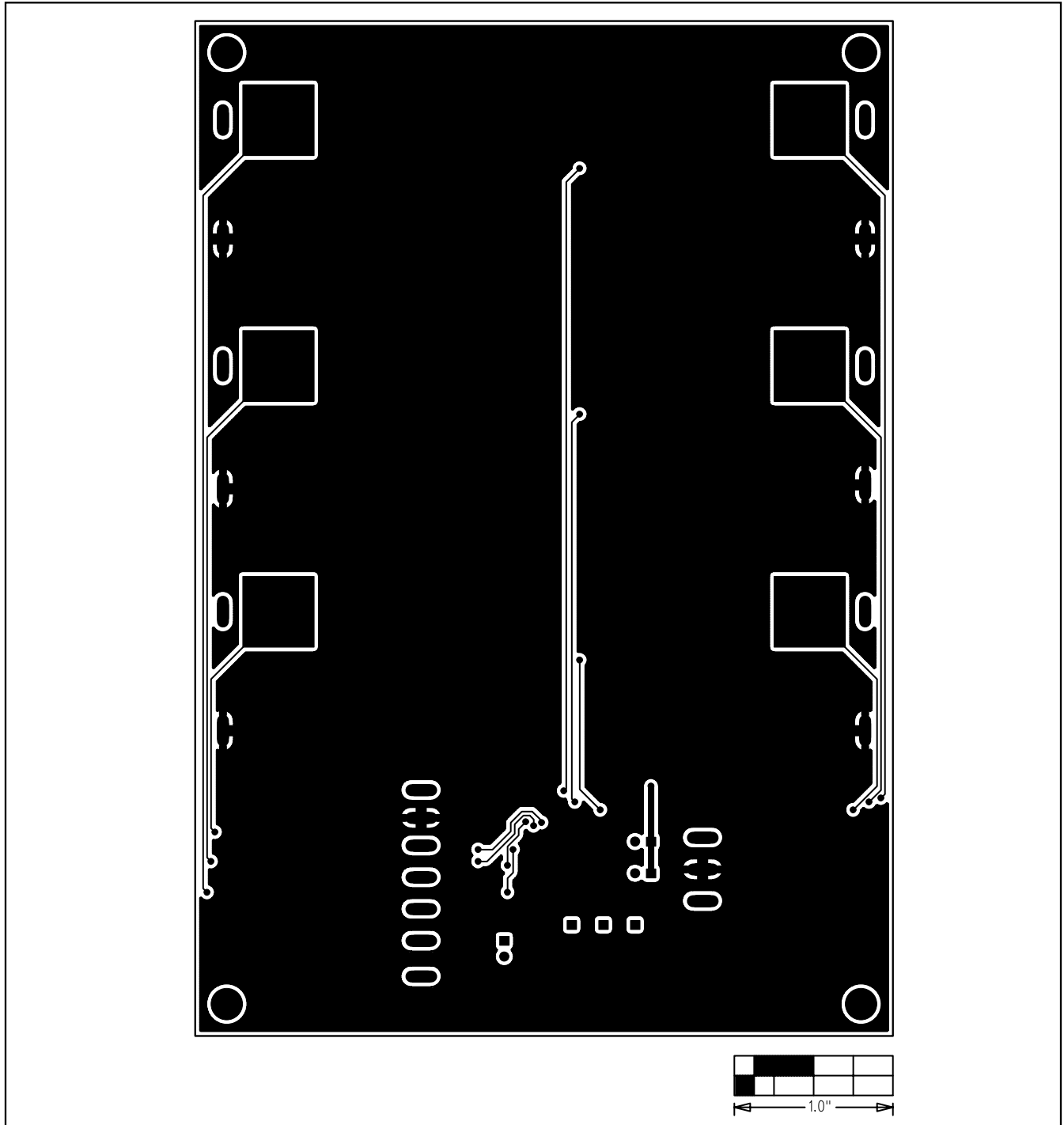

Figure 4. MAX6877 EV Kit PC Board Layout—Solder Side

Maxim cannot assume responsibility for use of any circuitry other than circuitry entirely embodied in a Maxim product. No circuit patent licenses are implied. Maxim reserves the right to change the circuitry and specifications without notice at any time.

8 _____ **Maxim Integrated Products, 120 San Gabriel Drive, Sunnyvale, CA 94086 408-737-7600**