

LINEAR HALL EFFECT IC**AH49H**

General Description

The AH49H is a small, versatile linear Hall-effect device that is operated by the magnetic field from a permanent magnet or an electromagnet. The output voltage is set by the supply voltage and varies in proportion to the strength of the magnetic field.

The integrated circuitry features low noise output, which makes it unnecessary to use external filtering components. It also includes precision resistors to provide increased temperature stability and accuracy. The operating temperature range of these linear Hall sensors is -40°C to 105°C , appropriate for commercial, consumer, and industrial environments.

The AH49H is available in standard TO-92S-3 and SOT-23-3 packages.

Features

- Miniature Construction
- Power Consumption of 2mA at $V_{CC}=3.3\text{V}$ for Energy Efficiency
- Single Current Sourcing Output
- Linear Output for Circuit Design Flexibility
- Low Noise Output Virtually Eliminates the Need for Filtering
- A Stable and Accurate Output
- Temperature Range: -40°C to 105°C
- Responds to Either Positive or Negative Gauss
- The Maximum Instantaneous Supply Voltage Up to 50V
- High ESD Rating: 6000V (Human Body Model) 400V (Machine Model)

Application

- Current Sensing
- Motor Control
- Position Sensing
- Magnetic Code Reading
- Rotary Encoder
- Ferrous Metal Detector
- Vibration Sensing
- Liquid Level Sensing
- Weight Sensing

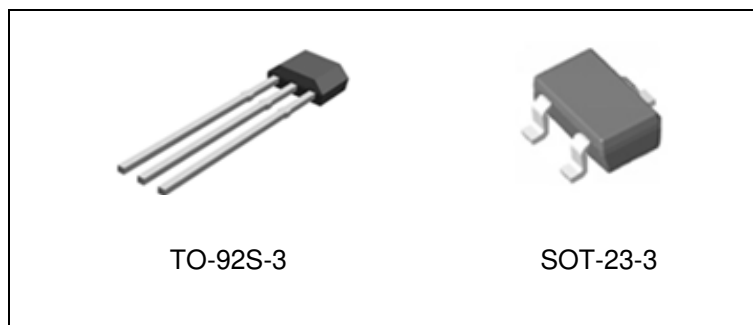

Figure 1. Package Types of AH49H

Pin Configuration

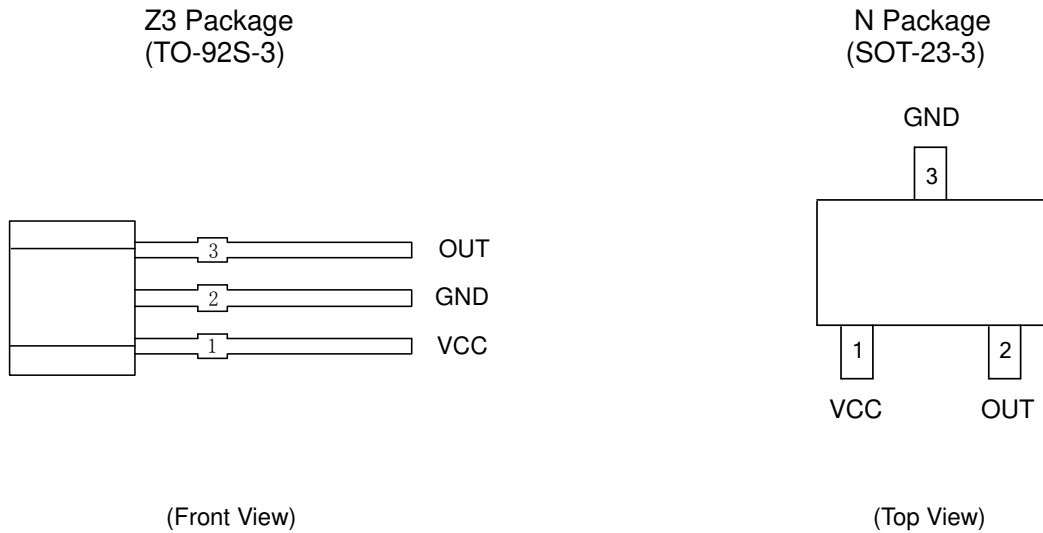

Figure 2. Pin Configuration of AH49H

Pin Description

Pin Number		Pin Name	Function
TO-92S-3	SOT-23-3		
1	1	VCC	Power supply pin
2	3	GND	Ground pin
3	2	OUT	Output pin

Functional Block Diagram

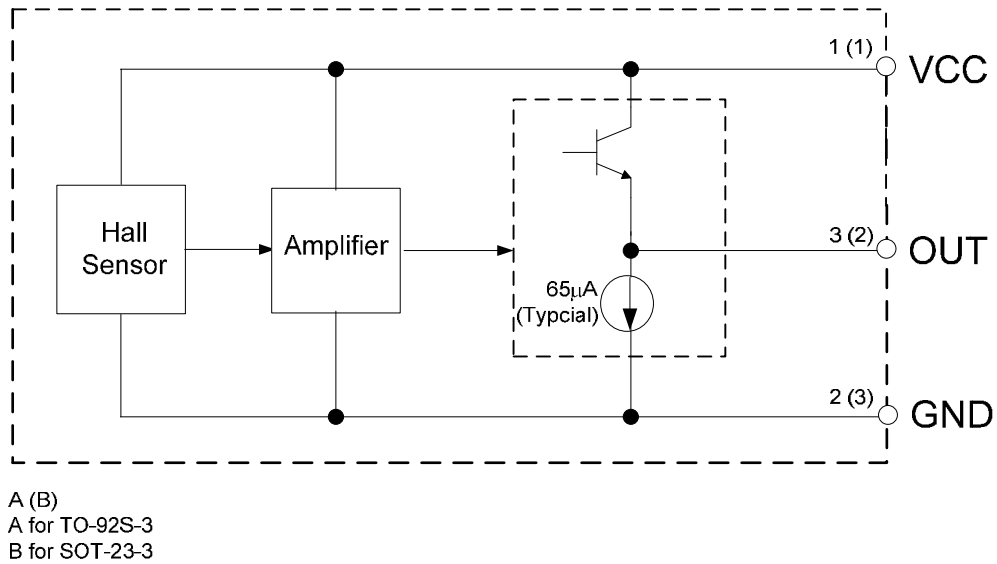
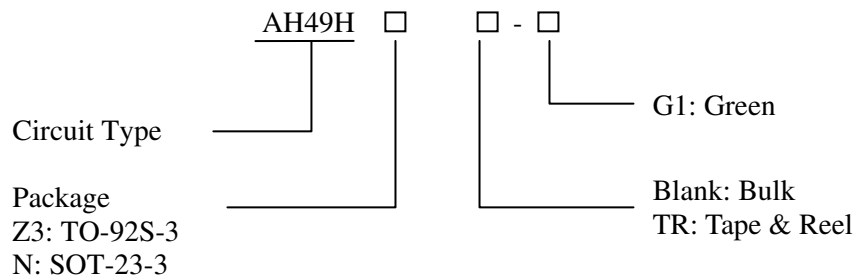

Figure 3. Functional Block Diagram of AH49H

Ordering Information



Package	Temperature Range	Part Number	Marking ID	Packing Type
TO-92S-3	-40 to 105°C	AH49HZ3-G1	49HG	Bulk
SOT-23-3		AH49HNTR-G1	GT7	Tape & Reel

BCD Semiconductor's Pb-free products, as designated with "G1" in the part number, are RoHS compliant and green.

**LINEAR HALL EFFECT IC****AH49H****Absolute Maximum Ratings (Note 1)**

Parameter	Symbol	Value	Unit
Supply Voltage	V_{CC}	10	V
Instantaneous Supply Voltage	V_{CC_INST}	50	V
Power Dissipation	TO-92S-3	400	mW
	SOT-23-3	230	
Ambient Temperature	T_A	-40 to 125	°C
Storage Temperature	T_{STG}	-50 to 150	°C
ESD (Human Body Model)		6000	V
ESD (Machine Mode)		400	V

Note 1: Stresses greater than those listed under “Absolute Maximum Ratings” may cause permanent damage to the device. These are stress ratings only, and functional operation of the device at these or any other conditions beyond those indicated under “Recommended Operating Conditions” is not implied. Exposure to “Absolute Maximum Ratings” for extended periods may affect device reliability.

Recommended Operating Conditions ($T_A=25^{\circ}\text{C}$)

Parameter	Symbol	Min	Max	Unit
Supply Voltage	V_{CC}	3	8	V
Operating Temperature	T_{OP}	-40	105	°C

LINEAR HALL EFFECT IC

AH49H

Electrical Characteristics

$V_{CC}=3.3V$, $T_A=25^{\circ}C$, unless otherwise specified.

Parameter	Symbol	Conditions	Min	Typ	Max	Unit
Supply Current	I_{CC}		1.2	2	3.2	mA
Quiescent Output Voltage	V_{NULL}	$B=0$ (Gauss)	1.45	1.7	1.85	V
Output Voltage Sensitivity	V_{SEN}	$B=\pm 600$ (Gauss)		0.33		mV/Gauss
Output Voltage Span	$V_{OUT\ S}$			0.85 to 2.6		V
Output Resistor	R_{OUT}		30	50	70	Ω
Linear Magnetic Range	B			± 3000		Gauss
Output Noise		Bandwidth=10Hz to 10kHz		90		μV

Transferring Characteristics ($V_{CC}=3.3V$)

When there is no outside magnetic field ($B=0$ Gauss), the quiescent output voltage is one-half the supply voltage in general.

For TO-92S-3 package, if a south magnetic pole approaches the front face (the side with marking ID) of the Hall effect sensor, the circuit will drive the output voltage higher. In contrary, a north magnetic pole will drive the output voltage lower. The variations of voltage level up or down are symmetrical. Because the SOT-23-3 is reversed packaging with TO-92S-3, so the magnetic performance is also reversed. Therefore, if the reversed magnetic pole approaches the front face, the output is the same as TO-92S-3 package. Greatest magnetic sensitivity is obtained with a supply voltage of 8V, but at the cost of increased supply current and a slight loss of output symmetry. So, it is not

recommended to work in such condition unless the output voltage magnitude is a main issue. The output signal can be capacitively coupled to a next-level amplifier for further amplifying if the changing frequency of the magnetic field is high.

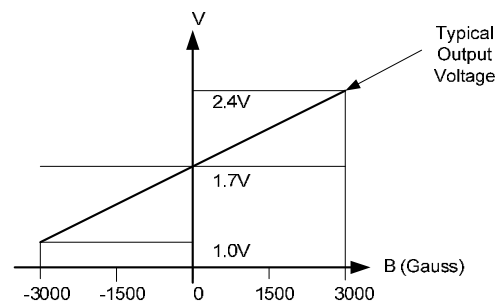

Figure 4. Transferring Characteristic of AH49H

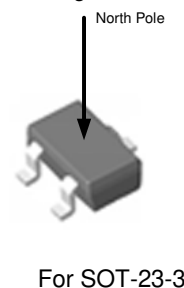
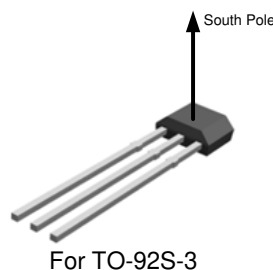

Figure 5. Magnetic Characteristic of AH49H

Typical Performance Characteristics

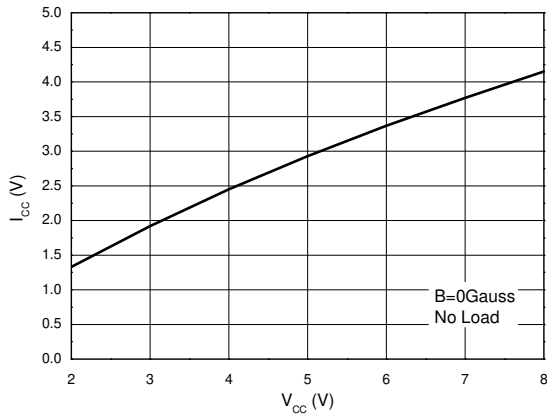

Figure 6. Supply Current vs. Supply Voltage

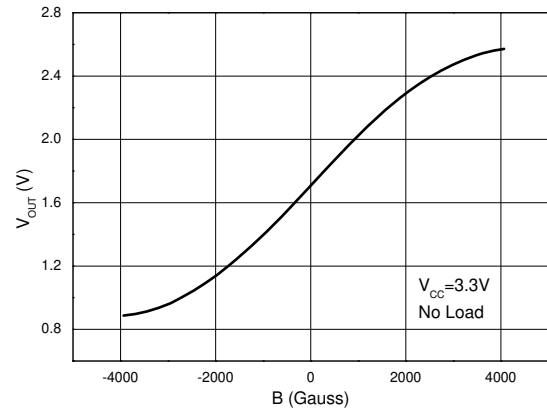

Figure 7. Output Voltage vs. Magnetic Field

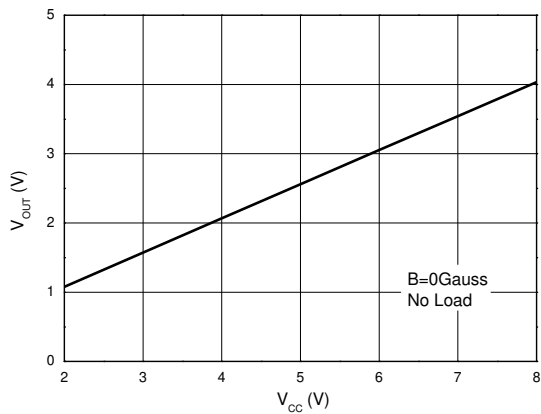

Figure 8. Output Voltage vs. Supply Voltage

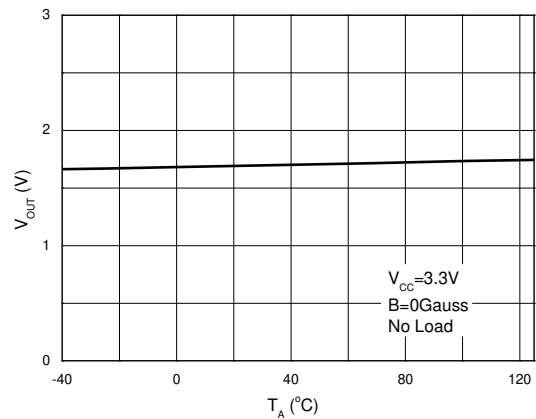

Figure 9. Output Voltage vs. Ambient Temperature

Typical Performance Characteristics (Continued)

Figure 10. Power Dissipation vs. Ambient Temperature

Mechanical Dimensions

TO-92S-3

Unit: mm(inch)

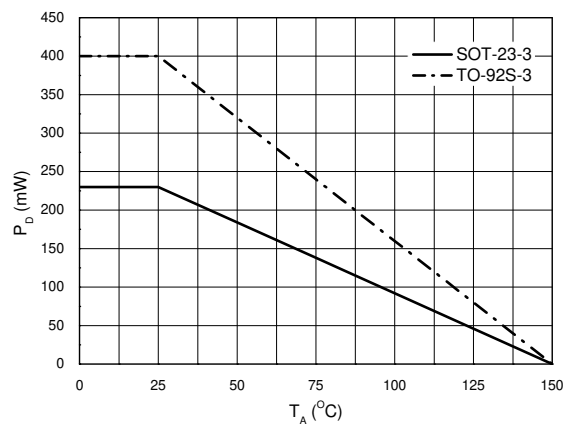
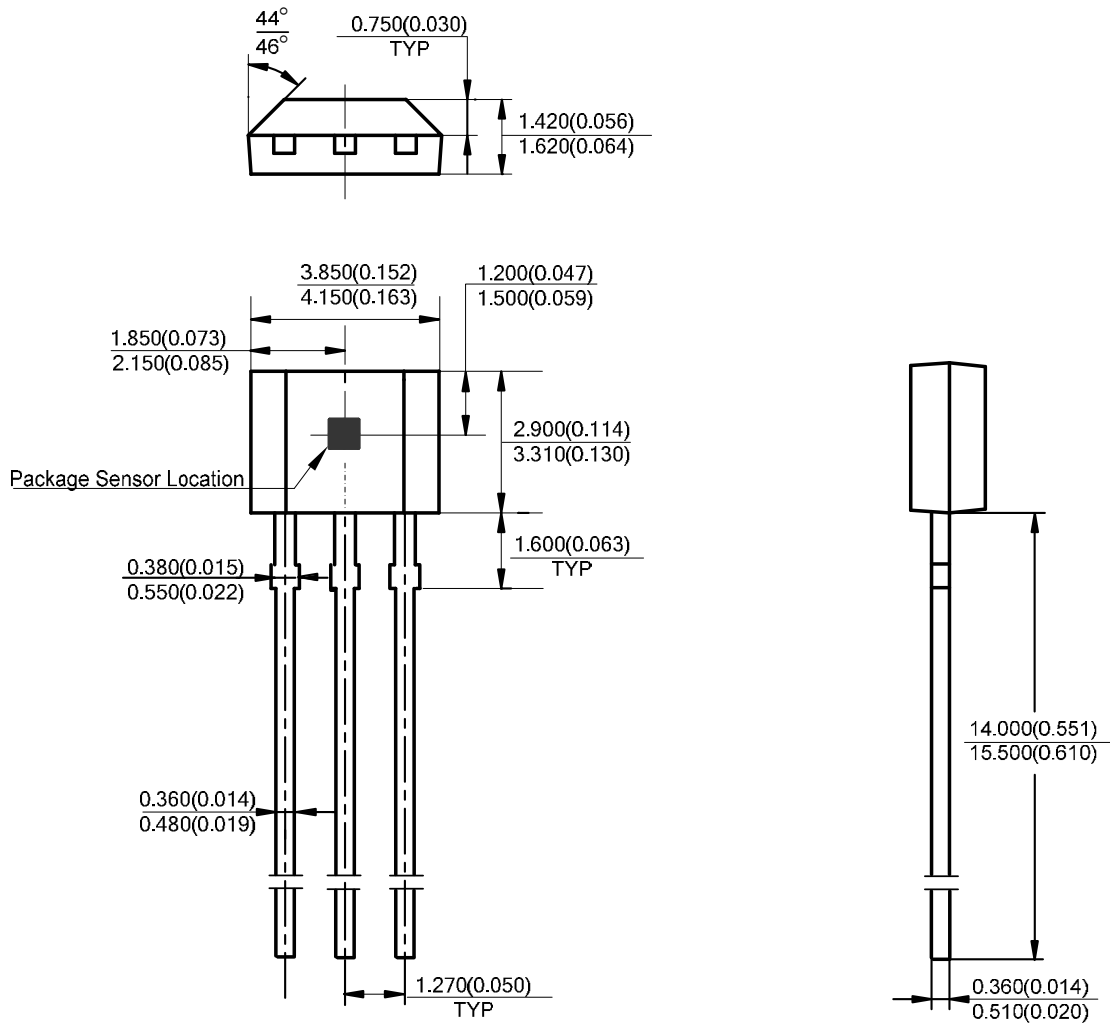

Mechanical Dimensions (Continued)

SOT-23-3

Unit: mm(inch)

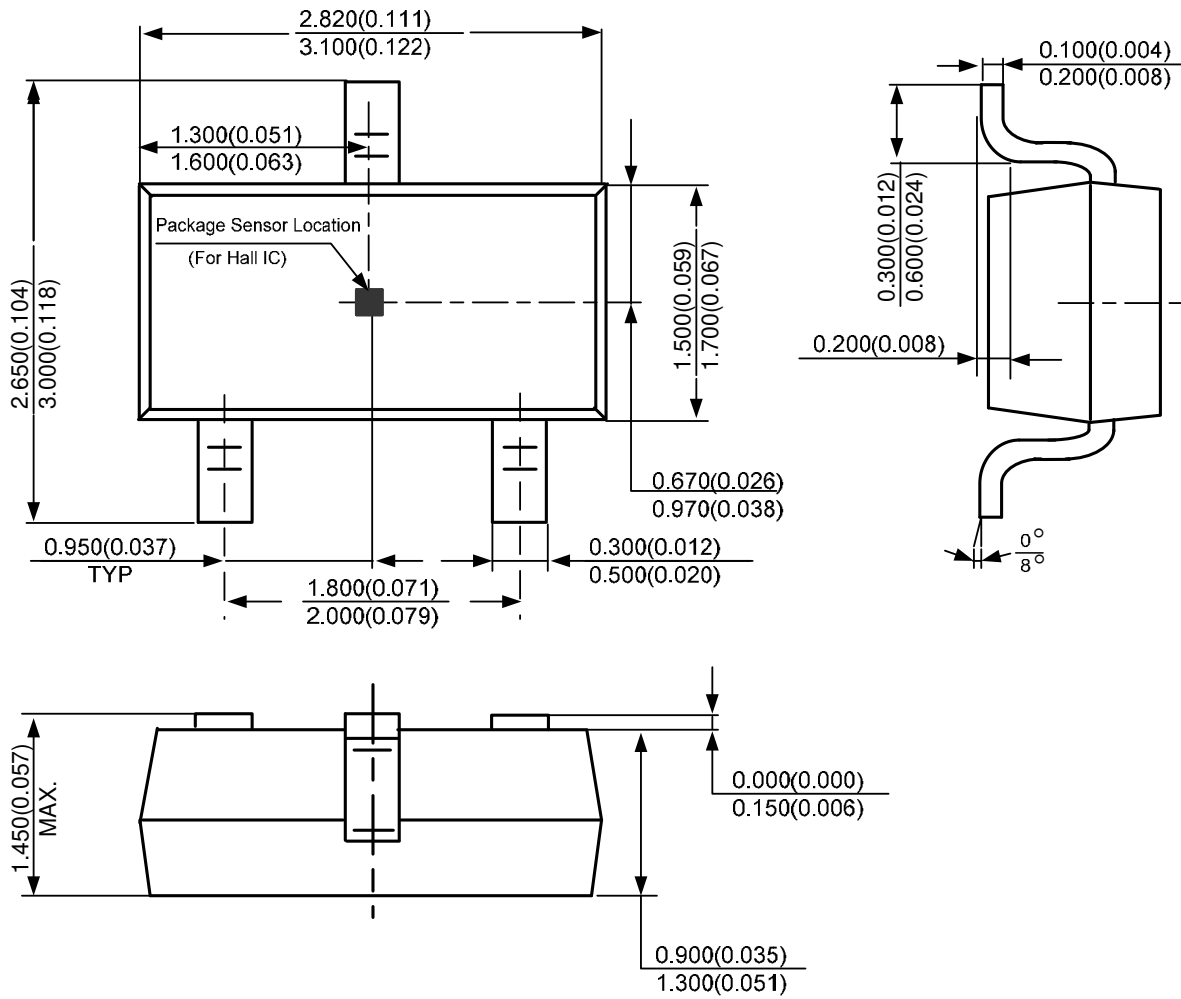



BCD Semiconductor Manufacturing Limited

<http://www.bcdsemi.com>

IMPORTANT NOTICE

BCD Semiconductor Manufacturing Limited reserves the right to make changes without further notice to any products or specifications herein. BCD Semiconductor Manufacturing Limited does not assume any responsibility for use of any its products for any particular purpose, nor does BCD Semiconductor Manufacturing Limited assume any liability arising out of the application or use of any its products or circuits. BCD Semiconductor Manufacturing Limited does not convey any license under its patent rights or other rights nor the rights of others.

MAIN SITE

- Headquarters

BCD (Shanghai) Micro-electronics Limited

No. 1600, Zi Xing Road, Shanghai ZiZhu Science-based Industrial Park, 200241, P. R. C.
Tel: +86-021-2416-2266, Fax: +86-021-2416-2277

- Wafer Fab

Shanghai SIM-BCD Semiconductor Manufacturing Co., Ltd.

800 Yishan Road, Shanghai 200233, China
Tel: +021-6485-1491, Fax: +86-021-5450-0008

REGIONAL SALES OFFICE

Shenzhen Office

Shanghai SIM-BCD Semiconductor Manufacturing Co., Ltd., Shenzhen Office

Unit A Room 1203, Skyworth Bldg., Gaoxin Ave.1.S., Nanshan District
Shenzhen 518057, China
Tel: +86-0755-8660-4900, Fax: +86-0755-8660-4958

Taiwan Office (Taipei)

BCD Semiconductor (Taiwan) Company Limited

3F, No.17, Lane 171, Sec. 2, Jiu-Zong Rd., Nei-Hu Dist., Taipei(114), Taiwan, R.O.C
Tel: +886-2-2656-2808
Fax: +886-2-2656-2806/26562950

Taiwan Office (Hsinchu)

BCD Semiconductor (Taiwan) Company Limited

8F, No.176, Sec. 2, Gong-Dao 5th Road, East District
HsinChu City 300, Taiwan, R.O.C
Tel: +886-3-5160181, Fax: +886-3-5160181

USA Office

BCD Semiconductor Corp.

48460 Kato Road, Fremont, CA 94538, USA
Tel: +1-510-668-1950
Fax: +1-510-668-1990

Korea Office

BCD Semiconductor Limited Korea office.

Room 101-1112, Digital-Empire II, 486 Sin-dong,
Yeongtong-Gu, Suwon-city, Gyeonggi-do, Korea
Tel: +82-31-695-8430