

REVISIONS				
P	LTR	DESCRIPTION	DATE	APVD
	T6	REVISED PER ECR-23-167923	20MAR2023	LP DSC

AMP WIRE RANGE	MILITARY WIRE RANGE
26-22 AWG STRANDED	26-24 AWG STRANDED

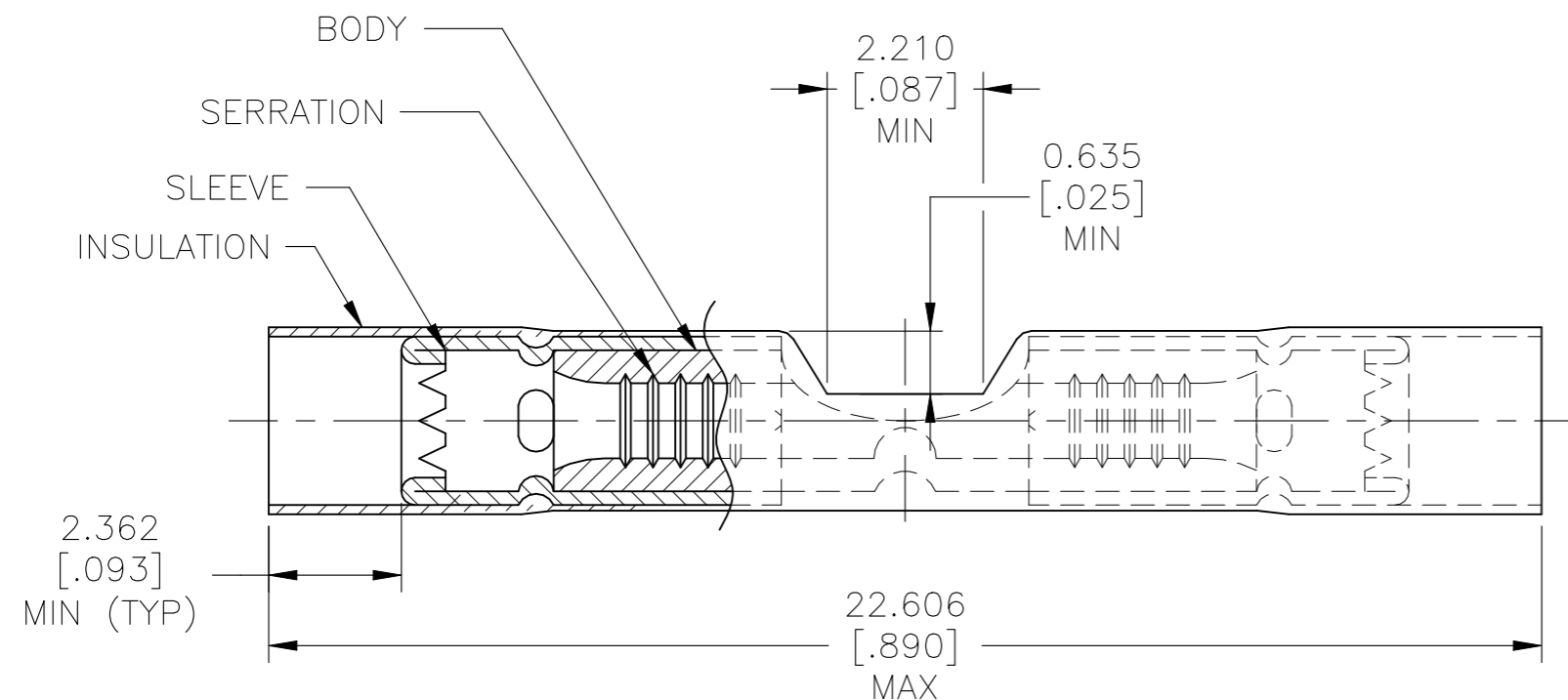

- 1 WIRE INSULATION DIAMETER: ϕ 1.270[.050] TO ϕ 2.083[.082]
- 2 MATERIAL:
BODY & SLEEVE - COPPER PER ASTM B152
INSULATION - NYLON
- 3 NOTE DELETED.
- 4 FINISH:
BODY & SLEEVE - TIN PLATE 0.00254[.000100]
MIN EXT THK PER ASTM B545
INSULATION COLOR - YELLOW

26-24 M7928/5-1 CLASS 1	QTY	PACKAGE TYPE	PART NO
--	25	LOOSE PIECE, BOX	8-323994-3
--	50	LOOSE PIECE, BOX	8-323994-2
--	4000	TAPE & REEL	2-323994-1
26-24 M7928/5-1 CLASS 1	50	LOOSE PIECE, FOIL BAG	323994
MILITARY P/N & CLASS PER SAE-AS7928			

AMP INCORPORATED CUSTOMER SERVICE SYSTEMS		MAX RECOMMENDED OPERATING TEMPERATURE: 105°C [221°F]	THIS DRAWING IS A CONTROLLED DOCUMENT.		DWN S.S. GOULDEN 9-28-93 CHK R. HERSEY 9-28-93 APVD M. ELLIS 9-28-93 PRODUCT SPEC APPLICATION SPEC 114-2157 WEIGHT -	TE Connectivity			
FOR ADDITIONAL PRODUCT INFORMATION OR COPIES OF DRAWINGS AND TECHNICAL DOCUMENTS PRODUCT INFORMATION CENTER 1-800-522-6752	FOR APPLICATION TOOLING ASSISTANCE CENTER TOOLING INFORMATION 1-800-722-1111	VOLTAGE RATING: 300 V MAX	DIMENSIONS: mm [INCHES]	TOLERANCES UNLESS OTHERWISE SPECIFIED: 0 PLC ± - 1 PLC ± - 2 PLC ± - 3 PLC ± 0.127[.005] 4 PLC ± - ANGLES ± -	NAME SPLICE, BUTT, PIDG, WIRE SIZE 26-22 AWG	SIZE A3	CAGE CODE 00779	DRAWING NO C-323994	RESTRICTED TO -
FOR ORDER ENTRY 1-800-526-5142	THIS DRAWING IS A CONTROLLED DOCUMENT FOR AMP INCORPORATED. IT IS SUBJECT TO CHANGE AND THE CONTROLLING ENGINEERING ORGANIZATION SHOULD BE CONTACTED FOR THE LATEST REVISION.		MATERIAL 2	FINISH 4	CUSTOMER DRAWING	SCALE NTS	SHEET 1 OF 1	REV T6	