

LUW025-Series Power Modules: dc-dc Converters: 36 Vdc to 75 Vdc In; 3.3 Vdc and 5 Vdc Out; 16.5 W and 25 W

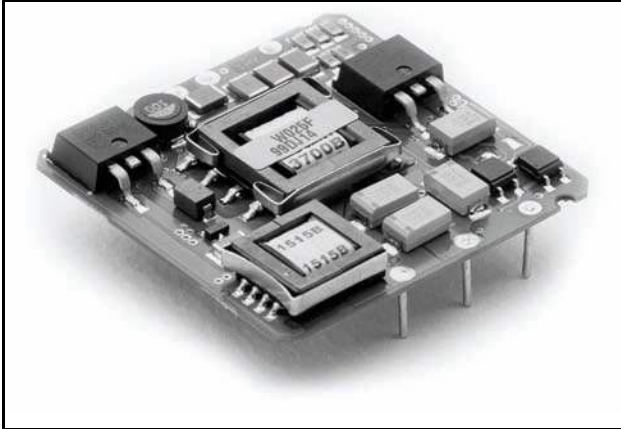

The LUW025-Series Power Modules use advanced, surface-mount technology and deliver high-quality, compact, dc-dc conversion at an economical price.

Applications

- Computer applications
- Communications equipment
- Distributed power architectures

Options

- Choice of remote on/off logic
- Short pins
- Surface mountable

Description

The LUW025-Series Power Modules are low-profile, open-frame dc-dc converters that operate over an input voltage range of 36 Vdc to 75 Vdc and provide a precisely regulated output. The output is isolated from the input, allowing versatile polarity configurations and grounding connections. The modules feature remote on/off and a wide range of output voltage adjustments. Built-in filtering for both input and output minimizes the need for external filtering.

Features

- Low profile and small size:
50 mm x 50 mm x 8.5 mm
(1.969 in. x 1.969 in. x 0.335 in.)
- Fixed frequency
- Wide operating temperature range
- Remote on/off
- Wide voltage adjustment (trim)
- Output overcurrent protection
- Output overvoltage protection
- Overtemperature protection
- ISO*9001 and ISO14001 Certified manufacturing facilities
- UL† 60950 Recognized, CSA‡ C22.2 No. 60950-00 Certified, VDE§ 0805 (IEC60950) Licensed
- CE mark meets 73/23/EEC and 93/68/EEC directives**

* ISO is a registered trademark of the International Organization for Standardization.

† UL is a registered trademark of Underwriters Laboratories, Inc.

‡ CSA is a registered trademark of Canadian Standards Association.

§ VDE is a trademark of Verband Deutscher Elektrotechniker e.V.

**This product is intended for integration into end-use equipment. All the required procedures for CE marking of end-use equipment should be followed. (The CE mark is placed on selected products.)

Absolute Maximum Ratings

Stresses in excess of the absolute maximum ratings can cause permanent damage to the device. These are absolute stress ratings only. Functional operation of the device is not implied at these or any other conditions in excess of those given in the operations sections of the data sheet. Exposure to absolute maximum ratings for extended periods can adversely affect device reliability.

Parameter	Symbol	Min	Typ	Max	Unit
Input Voltage:					
Continuous	V_I	0	—	80	Vdc
Transient (2 ms)	$V_{I, trans}$	0	—	100	V
Operating Temperature (See Thermal Considerations section.)	T_A	-40	—	75	°C
Storage Temperature	T_{stg}	-55	—	125	°C
I/O Isolation Voltage (for 1 minute)	—	—	—	1500	Vdc

Electrical Specifications

Unless otherwise indicated, specifications apply over all operating input voltage, resistive load, and temperature conditions.

Table 1. Input Specifications

Parameter	Symbol	Min	Typ	Max	Unit
Operating Input Voltage	V_I	36	48	75	Vdc
Maximum Input Current ($V_I = 0$ to 75 V; $I_O = I_{O, max}$; see Figures 1 and 2.)	$I_{I, max}$	—	—	1.36	A
Inrush Transient	I^2t	—	—	0.1	A ² s
Input Reflected-ripple Current (5 Hz to 20 MHz; 12 μ H source impedance; see Figure 10.)	I_I	—	3	—	mAp-p
Input Ripple Rejection (100 Hz—120 Hz)	—	—	60	—	dB
EMC, EN55022 (Nominal i/p volts, $I_O = I_{O, max}$)	(See EMC Considerations section.)				

Fusing Considerations

CAUTION: This power module is not internally fused. An input line fuse must always be used.

This encapsulated power module can be used in a wide variety of applications, ranging from simple stand-alone operation to an integrated part of a sophisticated power architecture. To preserve maximum flexibility, internal fusing is not included; however, to achieve maximum safety and system protection, always use an input line fuse. The safety agencies require a normal-blow fuse with a maximum rating of 5 A (see Safety Considerations section). Based on the information provided in this data sheet on inrush energy and maximum dc input current, the same type of fuse with a lower rating can be used. Refer to the fuse manufacturer's data for further information.

Electrical Specifications (continued)

Table 2. Output Specifications

Parameter	Device Suffix	Symbol	Min	Typ	Max	Unit
Output Voltage Set Point ($V_I = 48\text{ V}$; $I_O = I_{O, \text{max}}$; $T_{\text{ref}} = 25\text{ }^\circ\text{C}$)	F	$V_{O, \text{set}}$	3.25	3.30	3.35	Vdc
	A	$V_{O, \text{set}}$	4.92	5.00	5.08	Vdc
Output Voltage (Over all operating input voltage, resistive load, and temperature conditions until end of life; see Figure 12.)	F	V_O	3.16	—	3.44	Vdc
	A	V_O	4.85	—	5.15	Vdc
Output Regulation: Line ($V_I = 36\text{ V to }75\text{ V}$) Load ($I_O = I_{O, \text{min}}$ to $I_{O, \text{max}}$) Temperature ($T_{\text{ref}} = -40\text{ }^\circ\text{C to }+110\text{ }^\circ\text{C}$)	All	—	—	0.05	0.2	% V_O
	All	—	—	0.05	0.2	% V_O
	All	—	—	0.5	1.0	% V_O
Output Ripple and Noise Voltage: ($V_I = 48\text{ V}$; $I_O = I_{O, \text{max}}$; temperature = $-25\text{ }^\circ\text{C to }+100\text{ }^\circ\text{C}$; see Figure 11.): RMS (5 Hz to 20 MHz bandwidth) Peak-to-peak (5 Hz to 20 MHz bandwidth)	All	—	—	—	40	mVrms
	F	—	—	30	100	mVp-p
	A	—	—	50	100	mVp-p
External Load Capacitance (total capacitance; electrolytic, tantalum, and ceramic)	All	—	0	—	470	μF
Output Current (At $I_O < I_{O, \text{min}}$, the modules may exceed output ripple specifications.)	All	I_O	0.4	—	5.0	A
Output Current-limit Inception ($V_O = 90\%$ of $V_{O, \text{nom}}$)	All	$I_{O, \text{cli}}$	5.15	—	7.5	A
Efficiency ($V_I = 48\text{ V}$; $I_O = I_{O, \text{max}}$; $T_{\text{ref}} = 25\text{ }^\circ\text{C}$; see Figures 5, 6, and 12.): $V_O = 3.3\text{ V}$ Trimmed down to 1.8 V $V_O = 5\text{ V}$ Trimmed down to 3.3 V	F	η	76	78	—	%
	F	η	65	67	—	%
	A	η	77	79	—	%
	A	η	70	72	—	%
Switching Frequency	All	—	—	295	—	kHz
Dynamic Response ($\Delta I_O/\Delta t = 1\text{ A}/10\text{ }^\mu\text{s}$; $V_I = 48\text{ V}$; $T_{\text{ref}} = 25\text{ }^\circ\text{C}$; see Figures 7 and 8.): Load Change from $I_O = 50\%$ to 75% of $I_{O, \text{max}}$: Peak Deviation Settling Time ($V_O < 10\%$ of peak deviation) Load Change from $I_O = 50\%$ to 25% of $I_{O, \text{max}}$: Peak Deviation Settling Time ($V_O < 10\%$ of peak deviation)	All	—	—	50	—	mV
	All	—	—	1	—	ms
	All	—	—	50	—	mV
	All	—	—	1	—	ms

Table 3. Isolation Specifications

Parameter	Min	Typ	Max	Unit
Isolation Capacitance	—	2	—	nF
Isolation Resistance (250 Vdc)	10	—	—	$M\Omega$

Electrical Specifications (continued)

Table 4. General Specifications

Parameter	Device Suffix	Min	Typ	Max	Unit
Calculated MTBF ($I_O = 80\%$ of $I_{O, max}$; $T_A = 20\text{ }^\circ\text{C}$)	F		8,500,000		hours
	A		5,000,000		hours
Weight	All	—	—	28 (1)	g (oz.)

Table 5. Feature Specifications

Parameter	Device Suffix	Symbol	Min	Typ	Max	Unit
Remote On/Off Signal Interface ($V_I = 0\text{ V}$ to 75 V ; open collector or equivalent compatible; signal referenced to $V_I(-)$ terminal. See Feature Descriptions section and Figure 13.): Preferred Logic—Device Code Suffix “1”: Logic Low—Module On Logic High—Module Off Optional Logic: Logic Low—Module Off Logic High—Module On Logic Low: At $I_{on/off} = 1.0\text{ mA}$ At $V_{on/off} = 0\text{ V}$ Logic High: At $I_{on/off} = 0\text{ }\mu\text{A}$ Leakage Current Turn-on Time (At 80% of $I_{O, max}$; V_O within 10% of steady state; see Figure 9.)	All	$V_{on/off}$	0	—	1.2	V
	All	$I_{on/off}$	—	—	1.0	mA
	All	$V_{on/off}$	—	—	10	V
	All	$I_{on/off}$	—	—	50	μA
	All	—	—	27	50	ms
Output Voltage Adjustment Range (trim)	F	—	1.8	—	3.45	V
	A	—	3.3	—	5.25	V
Output Overvoltage Protection (clamp)	F	$V_{O, clamp}$	3.9	—	5	V
	A	$V_{O, clamp}$	5.6	—	7	V

Solder Ball and Cleanliness Requirements

The open frame (no case or potting) power module will meet the solder ball requirements per J-STD-001B. These requirements state that solder balls must neither be loose nor violate the power module minimum electrical spacing.

The cleanliness designator of the open frame power module is C00 (per J specification).

Solder, Cleaning, and Drying Considerations

Post solder cleaning is usually the final circuit-board assembly process prior to electrical board testing. The result of inadequate circuit-board cleaning and drying can affect both the reliability of a power module and the testability of the finished circuit-board assembly. For guidance on appropriate soldering, cleaning, and drying procedures, refer to the *Board-Mounted Power Modules: Soldering and Cleaning* Application Note (AP97-021EPS).

Characteristic Curves

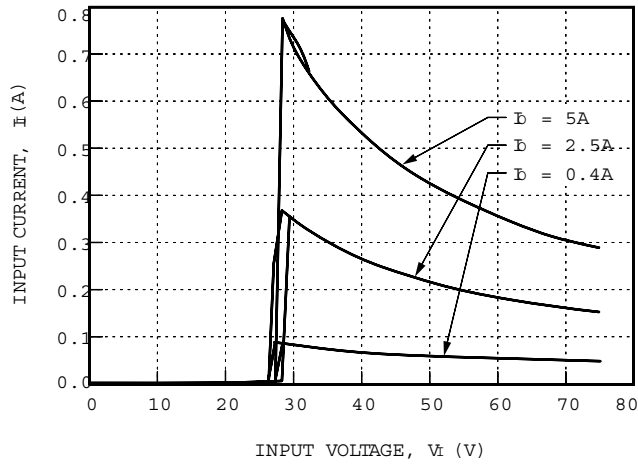

8-2233

Figure 1. LUW025F Typical Input Characteristics

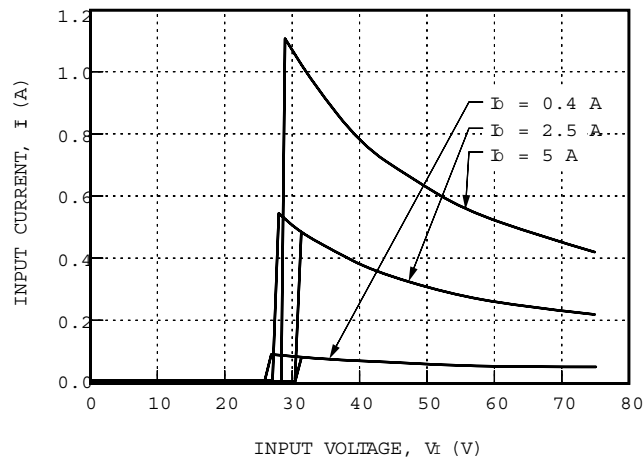

8-1982b

Figure 2. LUW025A Typical Input Characteristics

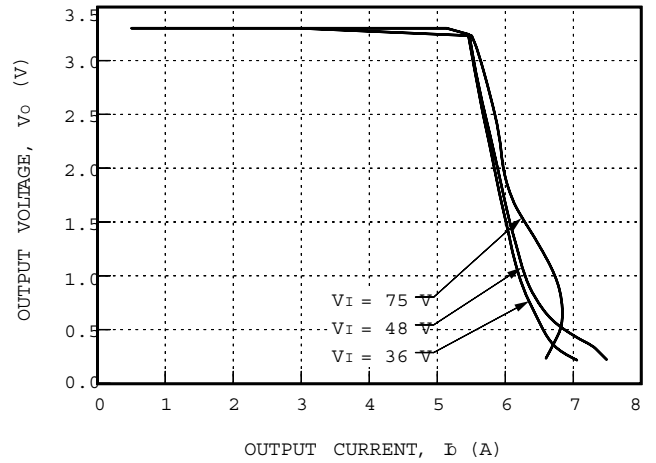

8-2234

Figure 3. LUW025F Typical Output Characteristics

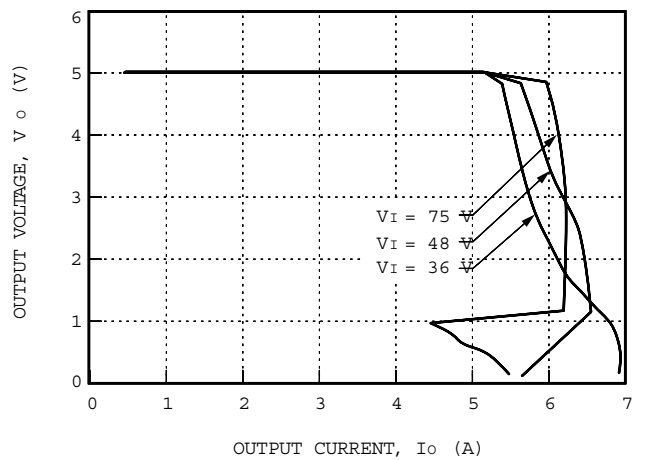

8-1983

Figure 4. LUW025A Typical Output Characteristics

Characteristics Curves (continued)

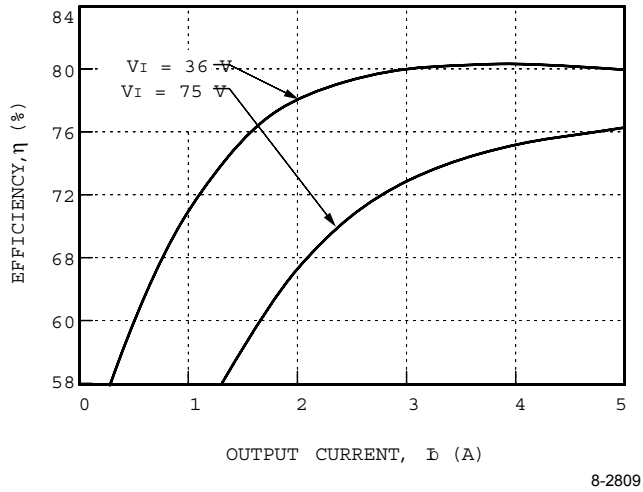

Figure 5. Typical LUW025F Converter Efficiency vs. Output Current, $T_A = 25\text{ }^\circ\text{C}$

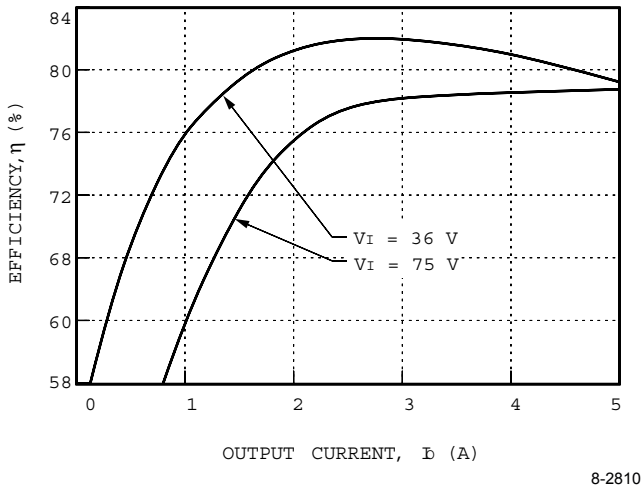

Figure 6. Typical LUW025A Converter Efficiency vs. Output Current, $T_A = 25\text{ }^\circ\text{C}$

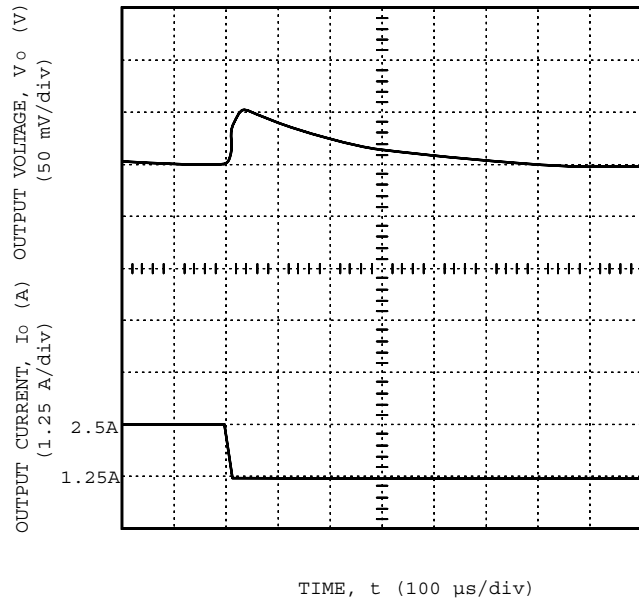

Figure 7. LUW025A, F Typical Output Voltage for a Step Load Change from 50% to 25%

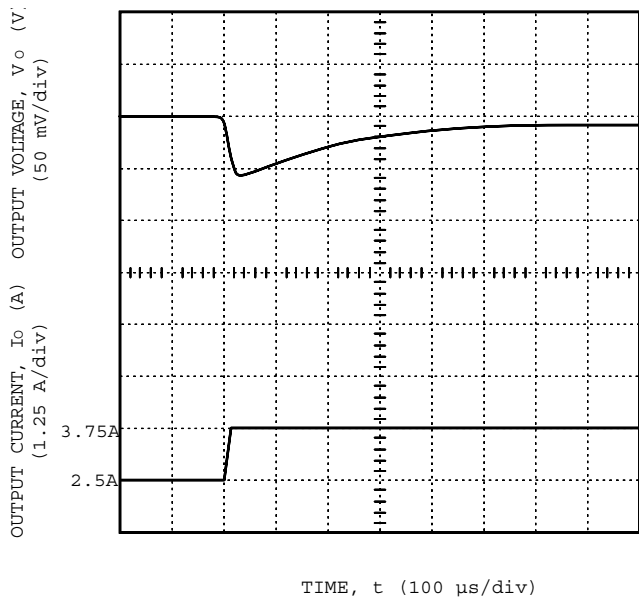

Figure 8. LUW025A, F Typical Output Voltage for a Step Load Change from 50% to 75%

Characteristics Curves (continued)

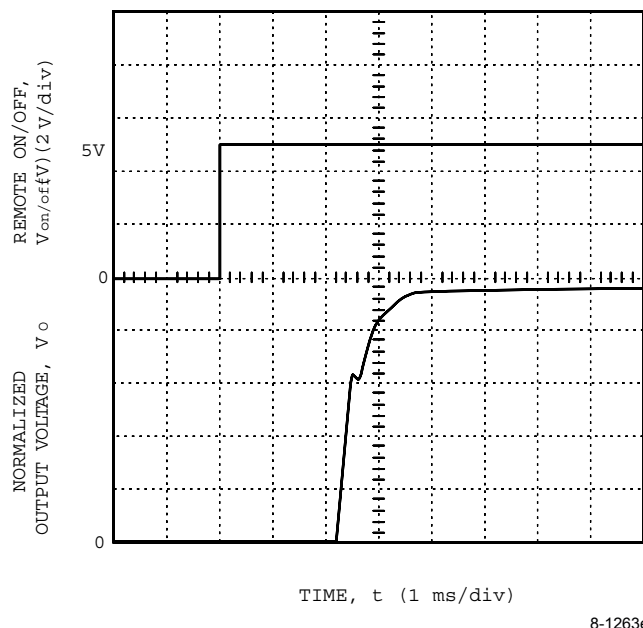
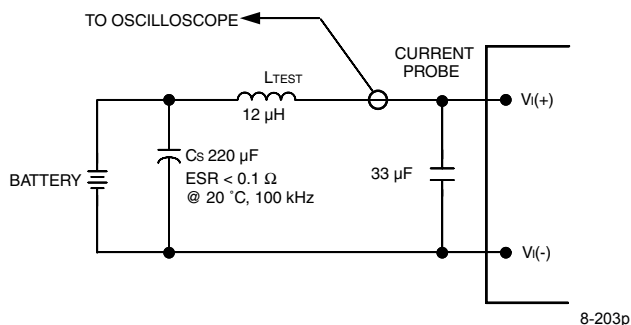

Figure 9. LUW025A, F Typical Output Voltage Start-Up when Signal Is Applied to Remote On/Off

Test Configurations



Note: Input reflected-ripple current is measured with a simulated source inductance (L_{TEST}) of 12 μH . Capacitor C_s offsets possible battery impedance. Current is measured at the input of the module.

Figure 10. Input Reflected-Ripple Test Setup

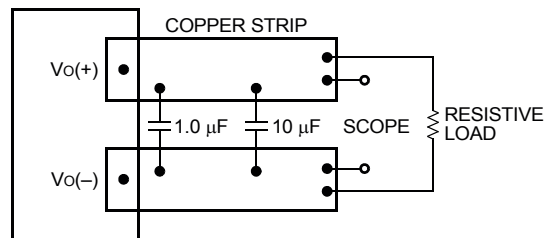

Note: Use one external 1 μF ceramic capacitor (nearest to the module) and one 10 μF aluminum or tantalum capacitor (nearest to the load). Scope measurement should be made using a BNC socket. Position the load between 50 mm and 75 mm (2 in. and 3 in.) from the module.

Figure 11. Peak-to-Peak Output Noise Measurement Test Setup

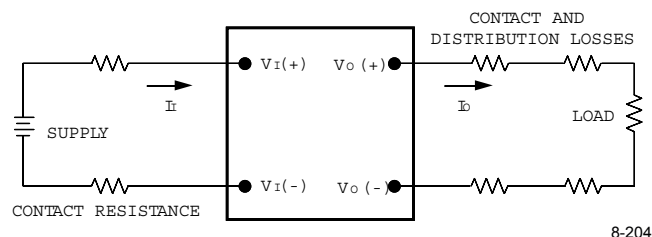

Note: All measurements are taken at the module terminals. When socketing, place Kelvin connections at module terminals to avoid measurement errors due to socket contact resistance.

$$\eta = \left(\frac{[V_O(+)-V_O(-)]I_O}{[V_I(+)-V_I(-)]I_I} \right) \times 100 \quad \%$$

Figure 12. Output Voltage and Efficiency Measurement Test Setup

Design Considerations

Input Source Impedance

The power module should be connected to a low ac-impedance input source (see Figure 10). Highly inductive source impedances can affect the stability of the power module. For the test configuration in Figure 10, a 33 μF electrolytic capacitor (ESR < 0.7 Ω at 100 kHz) mounted close to the power module helps ensure stability of the unit. For other highly inductive source impedances, consult the factory for further application guidelines.

Safety Considerations

For safety-agency approval of the system in which the power module is used, the power module must be installed in compliance with the spacing and separation requirements of the end-use safety agency standard, i.e., *UL* 60950, *CSA* C22.2 No. 60950-00, and *VDE* 0805 (*IEC*60950).

If the input source is non-SELV (ELV or a hazardous voltage greater than 60 Vdc and less than or equal to 75 Vdc), for the module's output to be considered meeting the requirements of safety extra-low voltage (SELV), all of the following must be true:

- n The input source is to be provided with reinforced insulation from any other hazardous voltages, including the ac mains.
- n One V_I pin and one V_O pin are to be grounded or both the input and output pins are to be kept floating.
- n The input pins of the module are not operator accessible.
- n Another SELV reliability test is conducted on the whole system, as required by the safety agencies, on the combination of supply source and the subject module to verify that under a single fault, hazardous voltages do not appear at the module's output.

Note: Do not ground either of the input pins of the module without grounding one of the output pins. This may allow a non-SELV voltage to appear between the output pins and ground.

The power module has extra-low voltage (ELV) outputs when all inputs are ELV.

The input to these units is to be provided with a maximum 5 A normal-blow fuse in the ungrounded lead.

Feature Descriptions

Overcurrent Protection

To provide protection in a fault (output overload) condition, the unit is equipped with internal current-limiting circuitry and can endure current limiting for an unlimited duration. At the point of current-limit inception, the unit shifts from voltage control to current control. If the output voltage is pulled very low during a severe fault, the current-limit circuit can exhibit either foldback or tailout characteristics (output-current decrease or increase). The unit operates normally once the output current is brought back into its specified range.

Remote On/Off

The remote on/off signal is referenced to the primary and is available with either positive or negative logic. Positive logic remote on/off turns the module on during a logic-high voltage on the REMOTE ON/OFF pin, and off during a logic low. Negative logic, device code suffix "1," turns the module off during a logic high and on during a logic low and is the factory-preferred configuration (see the Feature Specifications table).

To turn the power module output on and off, the user must supply a switch to control the voltage between the on/off terminal and the $V_I(-)$ terminal ($V_{on/off}$). The switch may be an open collector or equivalent (see Figure 13). A logic low is $V_{on/off} = 0$ V to 1.2 V. The maximum $I_{on/off}$ during a logic low is 1 mA. The switch should maintain a logic-low voltage while sinking 1 mA.

During a logic high, the maximum $V_{on/off}$ generated by the power module is 10 V. The maximum allowable leakage current of the switch at $V_{on/off} = 10$ V is 50 μ A.

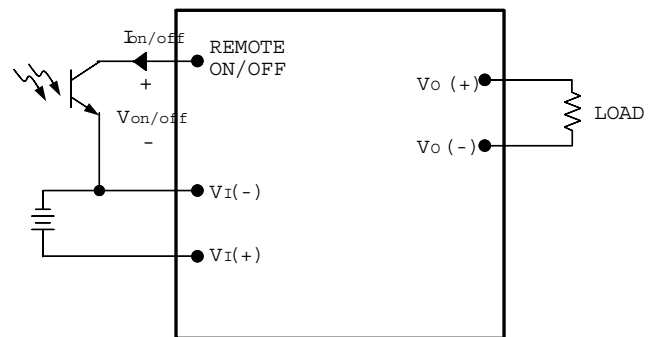

8-758e

Figure 13. Remote On/Off Implementation

Output Voltage Set-Point Adjustment (Trim)

Output voltage adjustment (trim) allows the user to increase or decrease the output voltage set point of a module. This is accomplished by connecting an external resistor between the TRIM pin and either the $V_O(+)$ or $V_O(-)$ pin.

Connecting an external resistor between the TRIM pin and $V_O(-)$ pin ($R_{adj-down}$) decreases the output voltage set point (see Figure 14). In order to maintain the output voltage accuracy, the trim resistor tolerance should be $\pm 0.1\%$.

Feature Descriptions (continued)

Output Voltage Set-Point Adjustment (Trim) (continued)

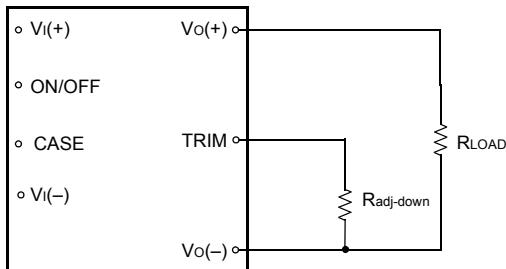

8-715h

Figure 14. Circuit Configuration to Decrease Output Voltage

The relationship between the output voltage and the trim resistor value for a $\gamma\%$ reduction in output voltage is:

$$R_{\text{adj-down}} = \left(\frac{511}{\Delta\%} - 6.11 \right) \text{ k}\Omega$$

Connecting an external resistor between the TRIM pin and Vo(+) pin ($R_{\text{adj-up}}$) increases the output voltage set point (see Figure 15).

The relationship between the output voltage and the trim resistor value for a $\gamma\%$ increase in output voltage is:

$$R_{\text{adj-up}} = \left(\frac{(V_o \cdot 5.11)(100 + \Delta\%)}{1.225\Delta\%} - \frac{511}{\Delta\%} - 6.11 \right) \text{ k}\Omega$$

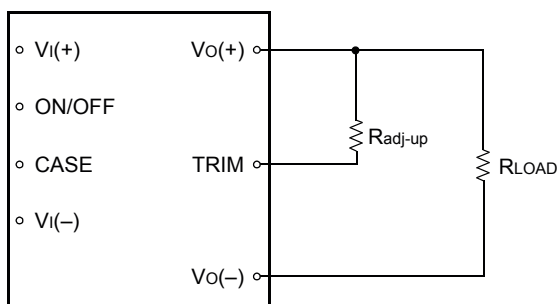

8-715g

Figure 15. Circuit Configuration to Increase Output Voltage

Output Overvoltage Protection

The output overvoltage clamp consists of control circuitry, independent of the primary regulation loop, that monitors the voltage on the output terminals. This control loop of the protection circuit has a higher voltage set point than the primary loop (see Feature Specifications table). In a fault condition, the overvoltage clamp ensures that the output voltage does not exceed $V_{O, \text{clamp, max}}$. This provides a redundant voltage-control that reduces the risk of output overvoltage.

Overtemperature Protection

These modules feature an overtemperature protection circuit to safeguard against thermal damage. The circuit shuts down and latches off the module when the maximum T_{ref} temperature is exceeded. The module will automatically restart when the T_{ref} temperature cools sufficiently.

Thermal Considerations

The power modules operate in a variety of thermal environments; however, sufficient cooling should be provided to help ensure reliable operation of the unit. Heat is removed by convection and radiation to the surrounding environment.

Considerations include ambient temperature, amount of airflow, module power dissipation, and need for increased reliability.

The monitor temperature reference point, T_{ref} , referenced in the specification is T1. Proper cooling can be verified by measuring the power module's temperature at the top center surface of T1 as shown in Figures 17—18. The temperature at the thermocouple location, T1, should not exceed 110 °C during the operation of the module. The output power of the module should not exceed the rated power.

The thermal data presented is based on measurements taken in a wind tunnel. The test setup shown in Figure 16 was used to collect data for Figures 17—18. Note that the orientation of the module with respect to airflow affects thermal performance. Two orientations are shown in Figures 17—18.

Thermal Considerations (continued)

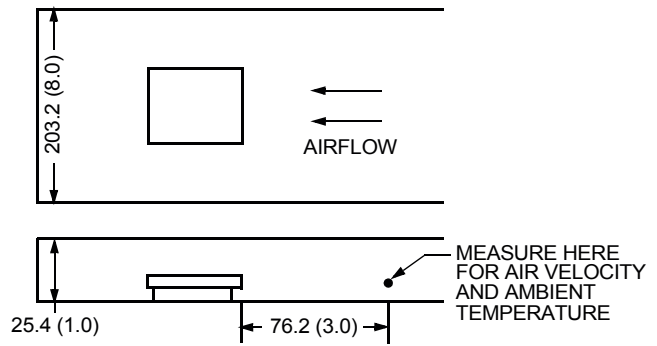

8-2603a

Note: Dimensions are in millimeters and (inches).

Figure 16. Thermal Test Setup

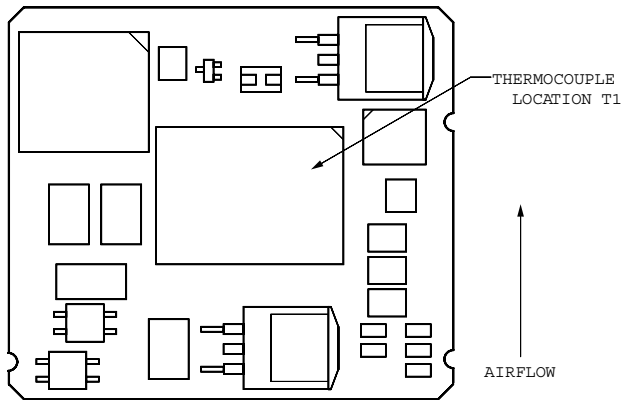

8-2788

Figure 17. T_a Temperature Measurement Location; Top View; Orientation 1

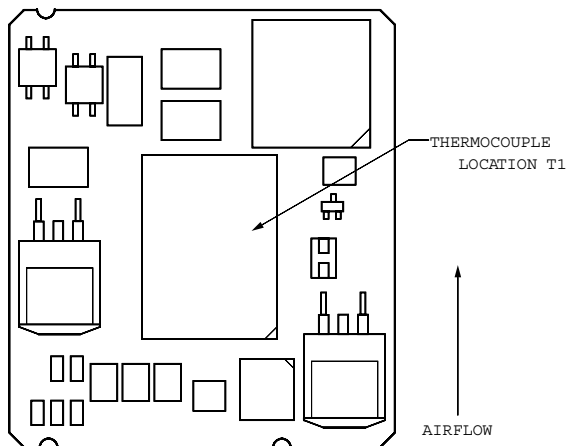

8-2789

Figure 18. T_a Temperature Measurement Location; Top View; Orientation 2

Convection Requirements for Cooling

To predict the approximate cooling needed for the module, determine the power dissipated as heat by the unit for the particular application. Figures 19—20 show typical heat dissipation for the module over a range of output currents.

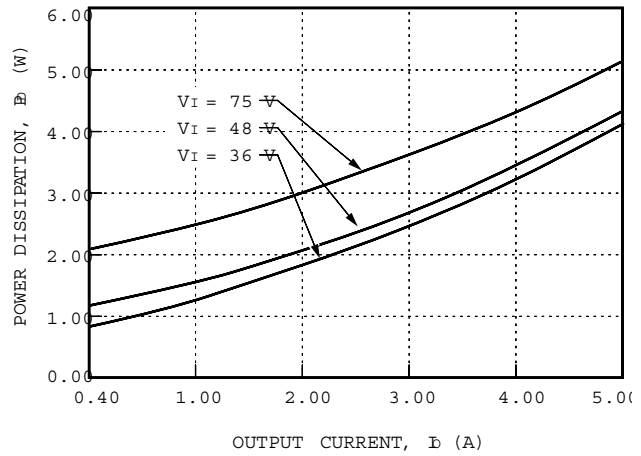

8-3026

Figure 19. LUW025F Power Dissipation vs. Output Current, $T_a = 25\text{ }^\circ\text{C}$; Either Orientation

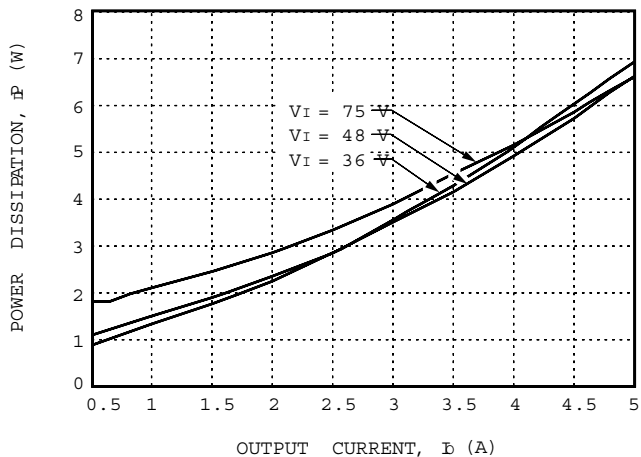

8-1888b

Figure 20. LUW025A Power Dissipation vs. Output Current, $T_a = 25\text{ }^\circ\text{C}$; Either Orientation

With the known heat dissipation, module orientation with respect to airflow, and a given local ambient temperature, the minimum airflow can be chosen from the derating curves in Figures 21—24.

Thermal Considerations (continued)

Convection Requirements for Cooling
(continued)

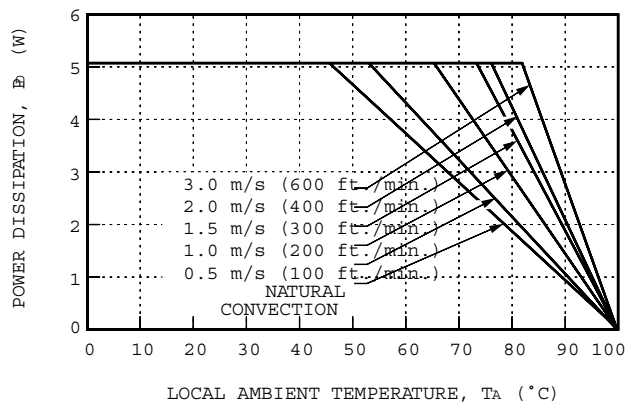

8-2980

Figure 21. LUW025F Power Derating vs. Local Ambient Temperature and Air Velocity; Orientation 1 (Preliminary)

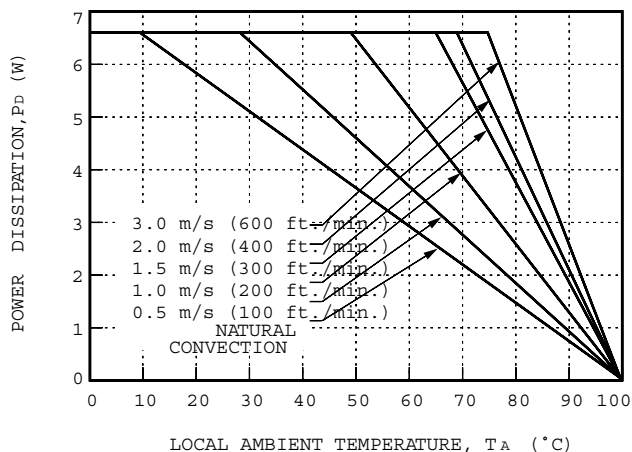

8-2981

Figure 22. LUW025A Power Derating vs. Local Ambient Temperature and Air Velocity; Orientation 1

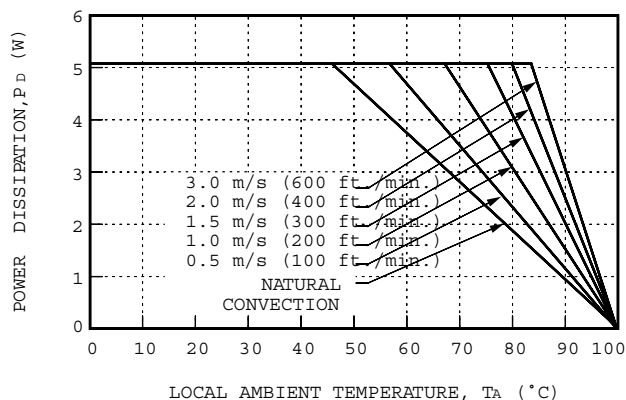

8-2979

Figure 23. LUW025F Power Derating vs. Local Ambient Temperature and Air Velocity; Orientation 2 (Preliminary)

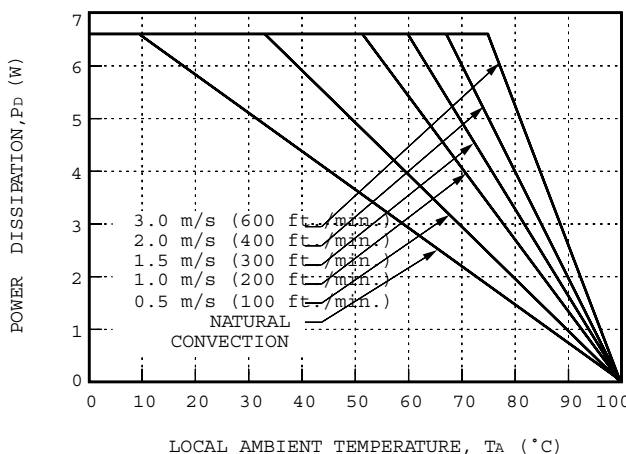

8-2982

Figure 24. LUW025A Power Derating vs. Local Ambient Temperature and Air Velocity; Orientation 2

For example, if the LUW025A dissipates 3 W of heat at 2.7 A load, the minimum airflow for Orientation 1 in a 80 °C environment is 1.0 m/s (200 ft./min.).

Keep in mind that these derating curves are approximations of the ambient temperatures and airflows required to keep the power module temperature below its maximum rating. Once the module is assembled in the actual system, the module's temperature should be checked as shown in Figures 17—18 to ensure it does not exceed 110 °C.

EMC Considerations

Figure 25 shows the suggested configuration to meet EN55022 Class B conducted limits.

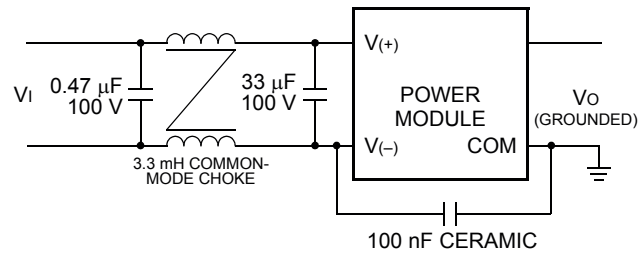

8-2684a

Figure 25. Suggested Configuration for EN55022

For assistance with designing for EMC compliance, refer to the *FLTR100V10 Filter Module* Data Sheet (DS99-294EPS).

Layout Considerations

Copper paths must not be routed beneath the power module conductive spacer. For additional layout guidelines, refer to the *FLTR100V10 Filter Module* Data Sheet (DS99-294EPS).

Outline Diagram (Surface Mount Outline)

Dimensions are in millimeters and (inches).

Tolerances: $x.x \pm 0.5$ mm (0.02 in.); $x.xx \pm 0.25$ mm (0.010 in.).

Top View

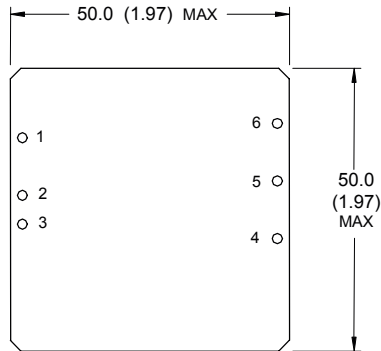

Side View

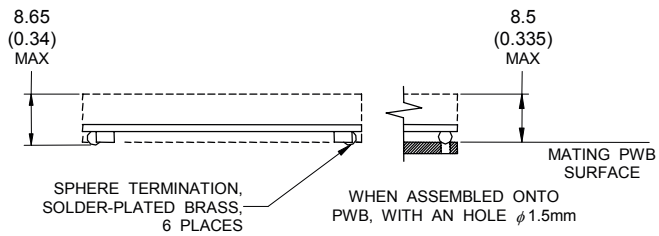

Bottom View

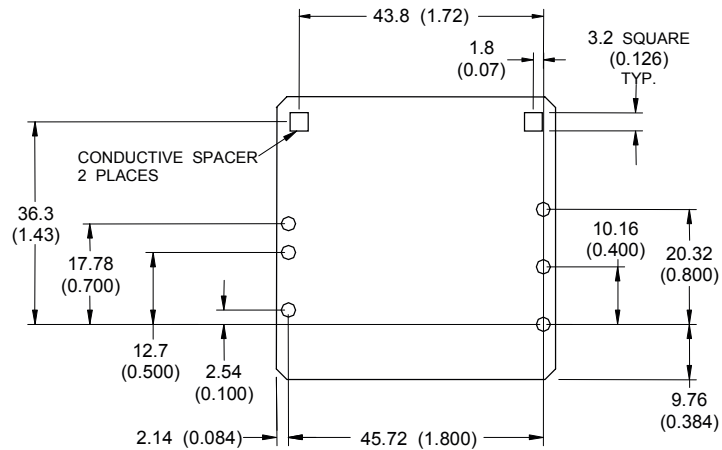

1-0222

Pin	Description
1	ON/OFF
2	$V_i(-)$
3	$V_i(+)$
4	$V_o(+)$
5	$V_o(-)$
6	TRIM

Recommended Hole Pattern (Surface Mount Footprint)

Component-side footprint. See pin descriptions on the previous page.

Dimensions are in millimeters and (inches).

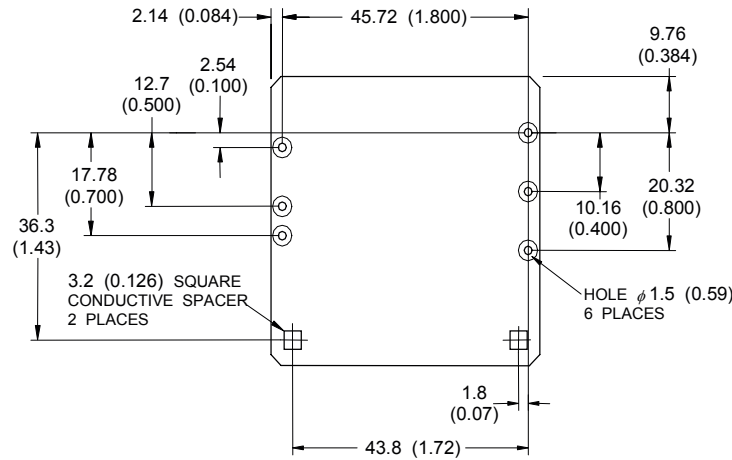

1-0224

Ordering Information

Please contact your Lineage Power Account Manager or Field Application Engineer for pricing and availability.

Table 6. Device Codes

Input Voltage	Output Voltage	Output Power	Device Code	Comcode
48 V	5 V	25 W	LUW025A	108409384
48 V	5 V	25 W	LUW025A8	108934258
48 V	5 V	25 W	LUW025A-S	108903469
48 V	3.3 V	16.5 W	LUW025F	108409392
48 V	3.3 V	16.5 W	LUW025F1-S	108869322
48 V	3.3 V	16.5 W	LUW025F6	108958257
48 V	3.3 V	16.5 W	LUW025F8	108934241
48 V	3.3 V	16.5 W	LUW025F-S	108959172

Optional features may be ordered using the device code suffixes shown below. The feature suffixes are listed numerically in descending order.

Table 7. Device Options

Option	Device Code Suffix
Surface mountable	-S
Short pins: 2.79 mm ± 0.25 mm (0.110 in. ± 0.010 in.)	8
Short pins: 3.81 mm ± 0.25 mm (0.150 in. ± 0.010 in.)	6
Negative remote on/off logic	1



LINEAGE POWER

World Wide Headquarters

Lineage Power Corporation

3000 Skyline Drive, Mesquite, TX 75149, USA

+1-800-526-7819

(Outside U.S.A.: **+1-972-284-2626**)

www.lineagepower.com

e-mail: techsupport1@lineagepower.com

Asia-Pacific Headquarters

Tel: +65 6416 4283

Europe, Middle-East and Africa Headquarters

Tel: +49 89 6089 286

India Headquarters

Tel: +91 80 28411633

Lineage Power reserves the right to make changes to the product(s) or information contained herein without notice. No liability is assumed as a result of their use or application. No rights under any patent accompany the sale of any such product(s) or information.

© 2008 Lineage Power Corporation, (Mesquite, Texas) All International Rights Reserved.

April 2008

FDS01-032EPS (Replaces FDS01-031EPS)