

10.3Gbps Thunderbolt™ and DisplayPort™ Switch

Features

- Supports 5.4Gbps for DisplayPort 1.2 and 10.3Gbps for Thunderbolt Electrical Standard
- Supports DP and DP++ Configuration
- Supports AUX and DDC MUX
- V_{DD} Operating Range for normal operation: 3.3V±10%
 - Extended operation down to 2.5V min on the LSTx/LSRx to TBC-9/TBC-11 channels (performance not guaranteed, but all buffers will still operate)
- ESD protection on all pins
 - 1.0kV HBM per JESD22 standard
- Packaging (Pb-free & Green):
 - 3.0 mm x 3.0 mm, 24-contact TQFN

Application

- Thunderbolt over mini-DP connector enablement

Pin Configuration (Top View)

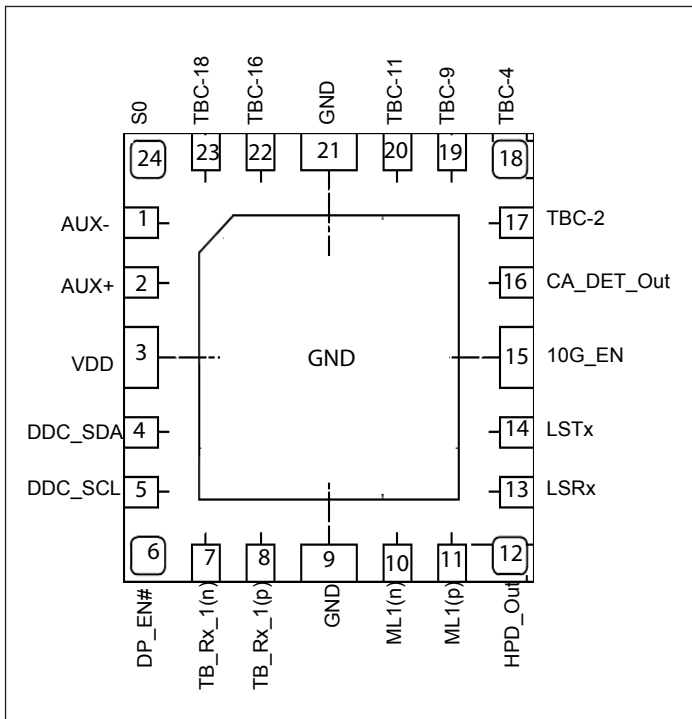

Description

Pericom Semiconductor's PI3TB212 is a high-speed multiplexer/demultiplexer switch. PI3TB212 can switch signals up to 10.3125Gbps for DisplayPort and Thunderbolt™(TB) applications. The device supports 5.4Gbps for DisplayPort and 10.3125Gbps for Thunderbolt.

PI3TB212 is a major advance over first-generation Thunderbolt solutions. PI3TB212 integrates the 10.3125 Gbps Thunderbolt path. This eliminates external PIN diode switches, thereby reducing board space, reducing cost, and improving link performance.

PI3TB212 achieves excellent signal integrity at 10.3125 Gbps as evidenced by measured results.

Block Diagram

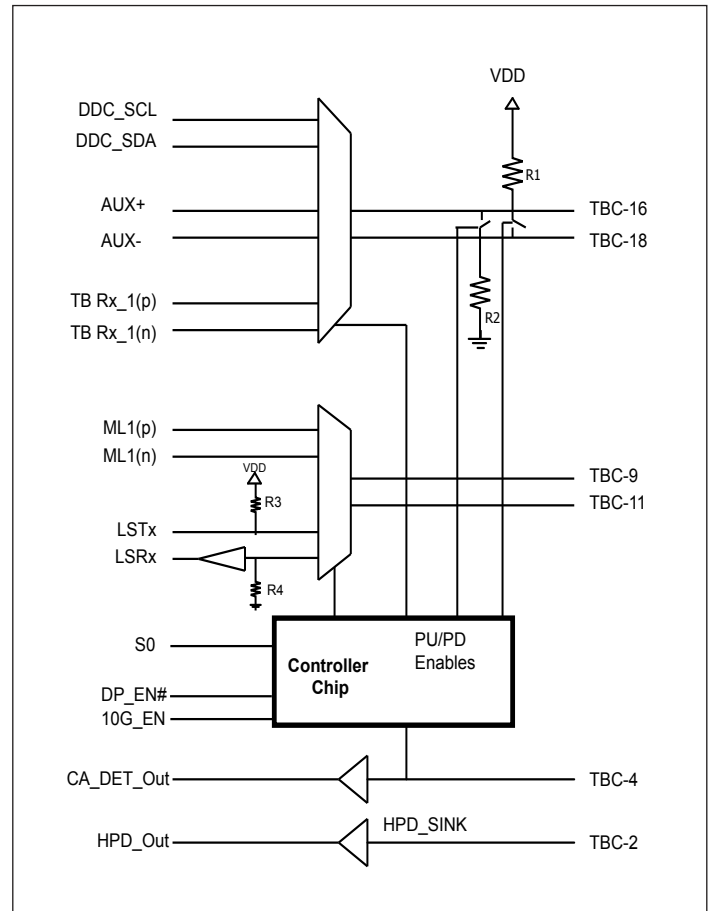

Pin Description

Pin #	Pin Name	Type	Description
17	TBC-2	I	Connector Side Hot Plug Detect Input. Connect to mini-DP connector pin2
11 10	ML1(p) ML1(n)	I/O	Controller Side Channel 1, DisplayPort Positive Signal (external AC coupling is required) Controller Side Channel 1, DisplayPort Negative Signal (external AC coupling is required)
22 23	TBC-16 TBC-18	I/O	Sink Side TB Rx1(p) or AUX+ Signal or DDC_SCL. Connect to mini-DP connector pin 16. Sink Side TB Rx1(n) or AUX- Signal or DDC_SDA. Connect to mini-DP connector pin 18.
19 20	TBC-9 TBC-11	I/O	Sink Side DP Main Link + Signal or LSTX. Connect to mini-DP connector pin 9. Sink Side DP Main Link - Signal or LSRX. Connect to mini-DP connector pin 11
2 1	AUX+ AUX-	I/O	Controller Side AUX Positive Signal Controller Side AUX Negative Signal
8 7	TB Rx_1(p) TB Rx_1(n)	I/O	Controller Side 10Gbps Positive Signal (external AC coupling is required) Controller Side 10Gbps Negative Signal (external AC coupling is required)
5 4	DDC_SCL DDC_SDA	I/O	Controller Side DDC Clock Controller Side DDC Data
18	TBC-4	I	Connector Side Cable Detect for DP++ Dongle. Connect to mini-DP connector pin 4.
12	HPD_Out	O	Controller Side Buffered Hot Plug Detect Output
14 13	LSTx LSRx	I/O O	Controller Side un-buffered UART TX Signal. Integrated 9KΩ pull-up Controller Side buffered UART RX Signal. 1MΩ pull-down present at buffer input
24	S0	I	Control signal. See truth table for detailed functionality
16	CA_DET_Out	O	Cable detect buffered output coming from TBC-4 (pin 18)
6	DP_EN#	I	DisplayPort path enable. See truth table for detailed functionality.
15	10G_EN	I	10G path enable. See truth table for detailed functionality.
3	VDD	Power	3.3V+/-10% power supply voltage
Center Pad, 9, 21	GND	Ground	Ground. both pins and center pad must all be connected to GND plane.

Description of Operation

Truth Table

Device States	Control Pins				Device and PU/PD Configurations			
	S0	10G_EN	DP_EN#	TBC-4	2:1 Mux	3:1 Mux	LSRx, HPD_Out, & CA_DET_Out buffers	R1, R2 status
Thunderbolt 10G mode	1 (System Active)	1	1	X	LSTx & LSRx	TB Rx_1	ALL BUFFERS ON	R1 = R2 = OFF
	0 (System Sleep)	1	1	X	LSTx & LSRx	Hi-z		R1 = R2 = OFF
DisplayPort Mode	1 (System Active)	0	0	0	DP ML1 (p, n)	AUX	ALL BUFFERS ON	R1 = R2 = ON
	0 (System Sleep)	0	0	0	Hi-Z	Hi-z		R1 = R2 = ON
TMDS Mode	1 (System Active)	0	0	1	DP ML1 (p, n)	DDC	ALL BUFFERS ON	R1 = R2 = ON
	0 (System Sleep)	0	0	1	Hi-Z	Hi-z		R1 = R2 = ON
Detect Mode	X - don't care	0	1	X	LSTx & LSRx	Hi-z	ALL BUFFERS ON	R1 = R2 = ON
Chip Disable mode	X - don't care	1	0	x	hi-z	hi-z	ALL BUFFERS ON	R1 = ON, R2 = ON
Power off (VDD = 0V)	X - don't care	x	x	x	hi-z	hi-z	ALL BUFFERS OFF	R1 = OFF, R2 = ON

ThunderBolt Connector Pins	Controller Pin Names
TBC-16	DDC_SCL or AUX(p) or TB RX_1 (p)
TBC-18	DDC_SDA or AUX(n) or TB RX_1 (n)
TBC-9	ML1 (p) or LSTx
TBC-11	ML1 (n) or LSRx
TBC-4	CA_DET_Out
TBC-2	HPD_Out

Maximum Ratings

(Above which useful life may be impaired. For user guidelines, not tested.)

Storage Temperature	-65°C to +150°C
Supply Voltage to Ground Potential	-0.5V to +4.6V
I/O (Pin7 and 8) DC Input Voltage	-0.5V to 1.5V
I/O (pin 1, 2, 4, and 5)	-0.5V to 4.0V
I/O (pin 10 and 11).....	-0.5V to 2.6V
I/O (pin 19 and 20)	-0.5V to 4.0V
DC Output Current	120mA
Power Dissipation	0.5W
Control Logic DC Input Voltage	VDD + 0.5V

Note: Stresses greater than those listed under MAXIMUM RATINGS may cause permanent damage to the device. This is a stress rating only and functional operation of the device at these or any other conditions above those indicated in the operational sections of this specification is not implied. Exposure to absolute maximum rating conditions for extended periods may affect reliability.

Electrical Characteristics
 Recommended Operating Conditions

Symbol	Parameter	Conditions	Min	Typ	Max	Units
VDD	3.3V Power Supply		3.0	3.3	3.6	V
I _{DD}	current consumption in normal operation	Control pins = GND or VDD, LSTx = VDD		300	780	uA
I _{DDQ} (System off)	Current consumption when S0 = 0	S0 = 0, TBC-2 and TBC-4 = GND or VDD, LSTx = VDD, all I/Os are floating		100	300	
I _{DD_detect}	Current consumption during detect	S0 = VDD, 10G_EN = 0, DP_EN# = VDD, LSTx = VDD, all I/Os are floating		120	300	
P _{DD}	Total Power from V _{DD} 3.3V supply	Control pins = GND or VDD, LSTx = VDD		1	2.8	mW
P _{DDQ} (System off)	Power consumption when S0 = 0	S0 = 0, TBC-2 and TBC-4 = GND or VDD, LSTx = VDD		330	1080	uW
P _{DD_Detect}	Power consumption during detect	S0 = VDD, 10G_EN = 0, DP_EN# = VDD, LSTx = VDD		400	1080	uW
T _{CASE}	Case operating temperature range		0		105	C

DC Electrical Characteristics for Switching over Operating Range

Parameters	Description	Test Conditions ⁽¹⁾	Min	Typ ⁽¹⁾	Max	
V _{IH}	Input HIGH Voltage for S0, DP_EN#, 10G_EN, TBC-4, TBC-2, TBC-11	VDD = 3.3V	1.8			V
V _{IL}	Input LOW Voltage for S0, DP_EN#, 10G_EN, TBC-4, TBC-2, TBC-11	VDD = 3.3V			0.8	
V _{IK}	Clamp Diode Voltage	VDD= Max., I _{IN} = -18mA		-0.7	-1.2	
I _{IH}	Input HIGH Current for S0, DP_EN#, 10G_EN, TBC-4, TBC-2	VDD = Max., V _{IN} = V _{DD}	-1		1	uA
I _{IL}	Input LOW Current for S0, DP_EN#, 10G_EN, TBC-4, TBC-2	VDD = Max., V _{IN} = 0V	-1		1	
I _{OFF} (TBC pins)	leakage from TBC-16	VDD = 0V, 1.5V present on TBC-16 TB Rx_1 (p/n) is floating	-60		+60	uA
	leakage from TBC-18	VDD = 0V, 1.5V present on TBC-18 TB Rx_1 (p/n) is floating	-20		+20	
	leakage from TBC-9, TBC-11, TBC-4, & TBC-2	VDD = 0V, 3.3V present on TBC pins ML1(p/n) is floating	-20		+20	

DC Electrical Characteristics for Switching over Operating Range

Parameters	Description	Test Conditions ⁽¹⁾	Min	Typ ⁽¹⁾	Max	Units
I _{Leakage}	Leakage on TB-16/TB-18 Thunderbolt 10G Mode	VDD = 3.6V. TB path on. Vin = 1.0V, TBRx_1 (p/n) is floating		20	50	μA
IOZL	I/O leakage for DDC/AUX	VDD = 3.6V. Vin = 0V		10	15	
	I/O leakage for TB Rx1(p/n)	VDD = 3.6V. Vin = 0V; TBC16, 18 = 0.2V		20	50	
	I/O leakage for ML1	VDD = 3.6V. Vin = 0V; TBC9, 11 = 0.5V		10	15	
	I/O leakage for LSTx	VDD = 3.6V. Vin = 0V	-600	-400	-300	
	I/O leakage for TBC9 and 11	VDD = 3.6V, Vin = 0V, ML1 (p/n) is floating		10	15	
	I/O leakage for TBC16 and 18	VDD = 3.6V, Vin = 0V, S0=low, 10G_EN = high, DP_EN# = high, TBRx_1 (p/n) is floating, Thunderbolt Mode		40	78	
IOZH	I/O leakage for DDC/AUX	VDD = 3.6V. Vin = VDD		10	15	
	I/O leakage for TB Rx1(p/n)	VDD = 3.6V. Vin = 0.5V		20	50	
	I/O leakage for ML1	VDD = 3.6V. Vin = 2.6V		10	15	
	I/O leakage for LSTx	VDD = 3.6V. Vin = VDD		10	15	
	I/O leakage for TBC9 and 11	VDD = 3.6V, Vin = VDD, ML1(p/n) is floating		10	15	
	I/O leakage for TBC16 and 18	VDD = 3.6V, Vin = VDD, S0=low, 10G_EN = high, DP_EN# = high, TBRx_1 (p/n) is floating, Thunderbolt mode		80	150	

R_{ON} Table

Parameters	Description	Test Conditions	Min.	Typ.	Max.	Units
R _{ON} AUX/LSTx	AUX & LSTx On Resistance	VDD = 3.3V Vin _{input} = 3.3V, I _{input} = -40mA		9	15	Ohms
R _{ON} TB	TB On Resistance	VDD = 3.3V Vin _{input} = 0V, I _{input} = -40mA		5	8	
R _{ON} DP	DP On Resistance	VDD = 3.3V Vin _{input} = 0V, I _{input} = -40mA		5	8	
R _{ON} DDC	DDC On Resistance	VDD = 3.3V Vin _{input} = 3.3V, I _{input} = -40mA		5	25	

Dynamic Electrical Characteristics

Parameter	Description	Test Conditions	Min.	Typ. ⁽¹⁾	Max.	Units
DDIL ⁽²⁾ (TB RX_1)	Insertion Loss on TB Rx_1 (p, n) to TBC-16 and TBC-18 path (V _{IN} = -10dBm, DC = 0V)	f=4.0GHz f=5.0GHz f=8.0GHz		-1.2 -1.5 -3.0		dB
DDIL (ML1)	Insertion Loss on ML1 (p, n) to TBC-9 and TBC-11 path (V _{IN} = -10dBm, DC = 0V)	f=810MHz (RBR) f=1.35GHz (HBR1) f=2.7GHz (HBR2)		-0.5 -0.7 -1.1		dB
DDRL ⁽²⁾ (TB Rx_1)	Differential Return Loss on 10G thunderbolt path	f= 4.0GHz f= 5.0GHz f= 8.0GHz		-24 -16 -9		dB
DDRL (ML1)	Differential Return Loss on DP path	f= 1.35GHz f= 2.7GHz f= 6.0GHz		-31 -27 -17		dB
Off-Isolation ³	Off-isolation for DP path	f = 810MHz f = 1.35GHz f = 2.7GHz		-27 -22 -16		dB
	Off-isolation for TB path	f = 4.0GHz f = 5.0GHz		-16 -15		dB

Notes:

1. Guaranteed by design. Typical values are at V_{DD} = 3.3V, T_A = 25°C ambient and maximum loading.
2. Refer to figure 1 for test setup
3. Refer to figure 3 for test setup

Buffers (HPD_Out, CA_DET_Out, TBC-2, TBC-4 and LSRx)

Parameters	Description	Test Conditions	Min.	Typ.	Max.	Units
VIH	Input high for TBC-2, TBC-4 and TBC-11	VDD = 3.6V	1.8			V
VIL	Input Low for TBC-2, TBC-4 and TBC-11	VDD = 3.6V			0.8	
VOH	Output high for HPD_Out, CA_DET_Out, and LSRx	VDD = 3.3V+/-10%, I _{oh} = -2mA	2.4		VDD	
VOL	Output Low for HPD_Out, CA_DET_Out and LSRx	VDD = 3.6V, I _{ol} = 2mA			0.8	

Timing

Parameter	Description	Test Conditions	Min.	Typ. ⁽¹⁾	Max.	Units
Tsw	Switching time between paths	VDD = 3.0V			2	us
Tstartup	VDD valid to channel enable	VDD valid = 2.7V VDD ramp is from 0V to 3.3V			10	us
Twakeup	From sleep mode to on mode (toggling S0)	VDD = 3.0V			2	us
Tb-b	Bit-to-bit skew within the same differential pair	VDD = 3.0V	(between pin 22 & 23)	2	5	ps
			(between pin 19 & 20)	2	5	

Linear region for Analog switches (non-buffered paths)

Parameter	Description	Test Conditions	Min.	Typ	Max.	Units
Vp_TBT	TB Rx_1(p) and TB Rx_1(n) path ⁽²⁾	VDD = 3.3V, Ipass = 10mA	1.0	1.3		V
Vp_AUX/DDC	AUX+, AUX-, DDC_SCL, & DDC_SDA path ⁽²⁾	VDD = 3.3V, Ipass = 10mA	3.6	4.2		V
Vp_ML	ML1(p) and ML1(n) path ⁽²⁾	VDD = 3.3V, Ipass = 10mA	2.2	2.5		V
Vp_LSTx	LSTx signal path ⁽²⁾	VDD = 3.3V, Ipass = 10mA	3.6	4.2		V

Pull-up/Pull-downs

Parameter	Description	Test Conditions	Min.	Typ. ⁽¹⁾	Max.	Units
R2	Pull-down value on AUX+ path	S0 = 10G_EN = DP_EN# = TBC-4 = 0V VDD = 3.3V, TBC-16 = 3.3V VDD = 0V, TBC-16 = 3.3V		88 88	105 105	Kohm
R1	Pull-up value on AUX- path	S0 = 10G_EN = DP_EN# = TBC-4 = 0V VDD = 3.3V, TBC-18 = 0V		88	105	Kohm
R4	Pull-down value on LSRx path	S0 = 10G_EN = 0V; DP_EN# = TBC-11 = 3.3V; VDD = 3.3V	1	1.5		Mohm
R3	Pull-up value on LSTx path	S0 = 10G_EN = 0V; DP_EN# = VDD; LSTx = 0V VDD = 3.3V		8.8	10.5	Kohm

Notes:

1. Typical values are at VDD = 3.3V, TA = 25°C ambient and maximum loading.
2. See figure 2 for test setup

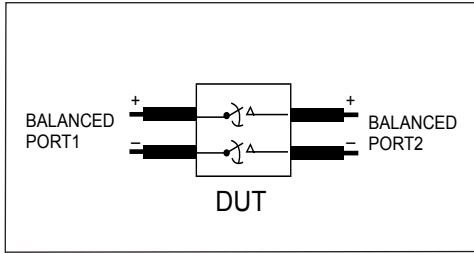

Fig 1: Diff. Insertion Loss and Return Test Circuit

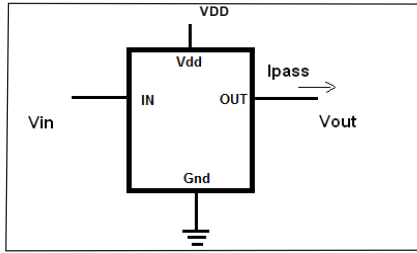

Fig 2: Linear Region Test Setup

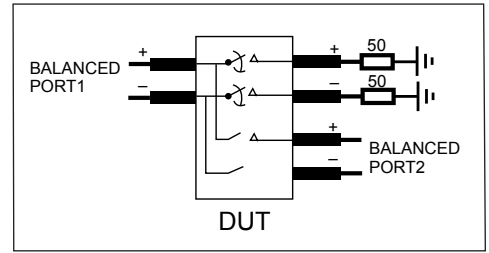
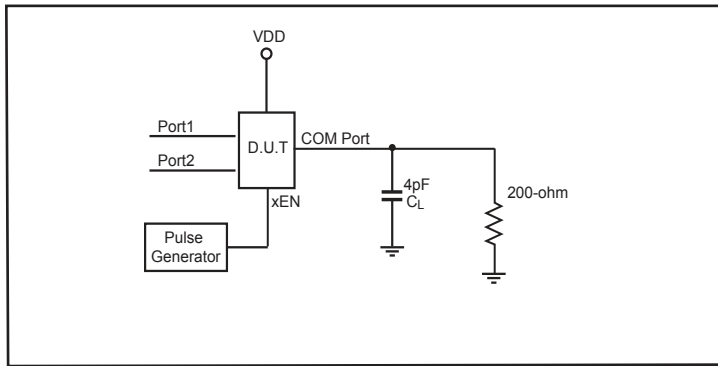

Fig 3: Diff. Off Isolation Test Circuit

Test Circuit for Electrical Characteristics⁽¹⁻⁵⁾



Notes:

1. C_L = Load capacitance: includes jig and probe capacitance.
2. R_T = Termination resistance: should be equal to Z_{OUT} of the Pulse Generator
3. Output 1 is for an output with internal conditions such that the output is low except when disabled by the output control.
output 2 is for an output with internal conditions such that the output is high except when disabled by the output control.
4. All input impulses are supplied by generators having the following characteristics: $PRR \leq \text{MHz}$, $Z_O = 50\Omega$, $t_R \leq 2.5\text{ns}$, $t_F \leq 2.5\text{ns}$.
5. The outputs are measured one at a time with one transition per measurement.

Switching Waveforms

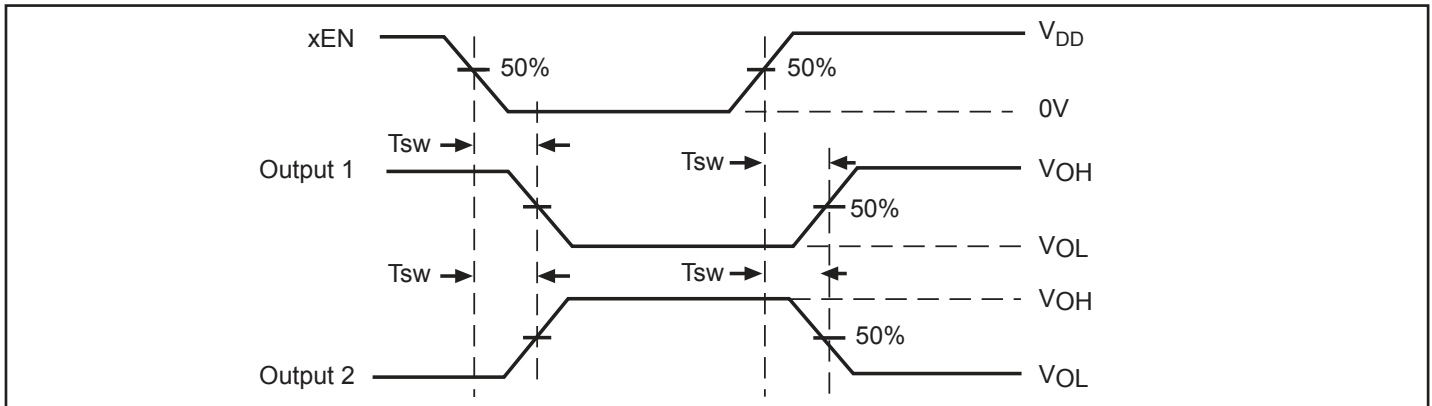

Test Condition:
Output1: Port 1=Low, Port 2=High
Output2: Port 1=High, Port 2=Low

Voltage Waveforms Switching Times

Measured Insertion loss for 10Gbps Thunderbolt Path at $V_{DD} = 3.3V$, $T_A = 25^\circ C$

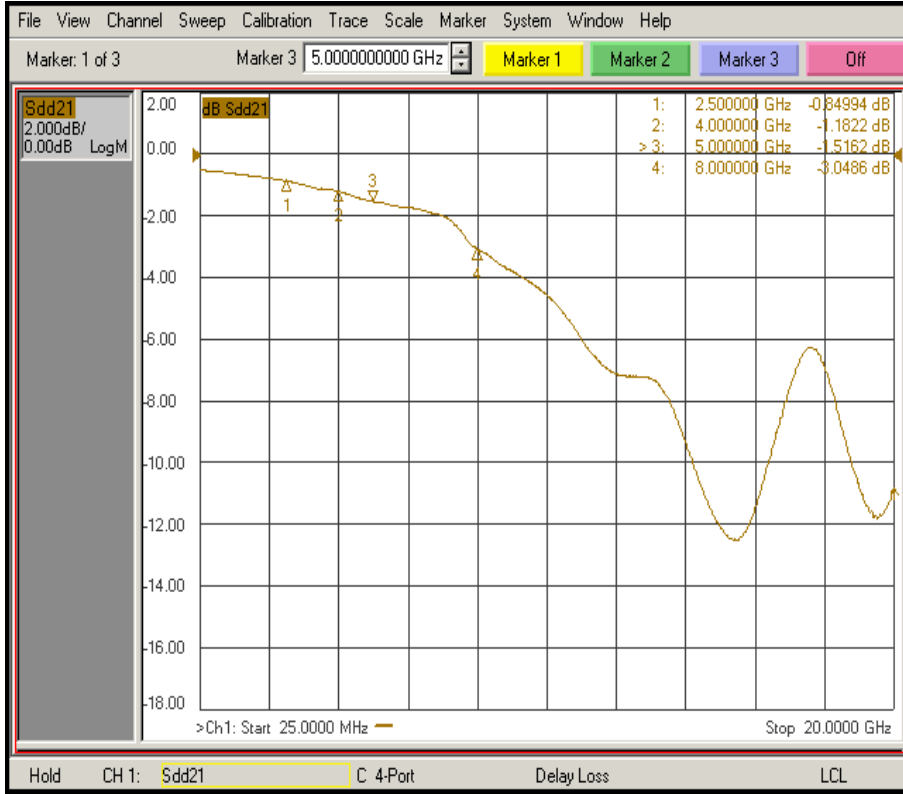

Measured Return loss for 10Gbps Thunderbolt Path at $V_{DD} = 3.3V$, $T_A = 25^\circ C$

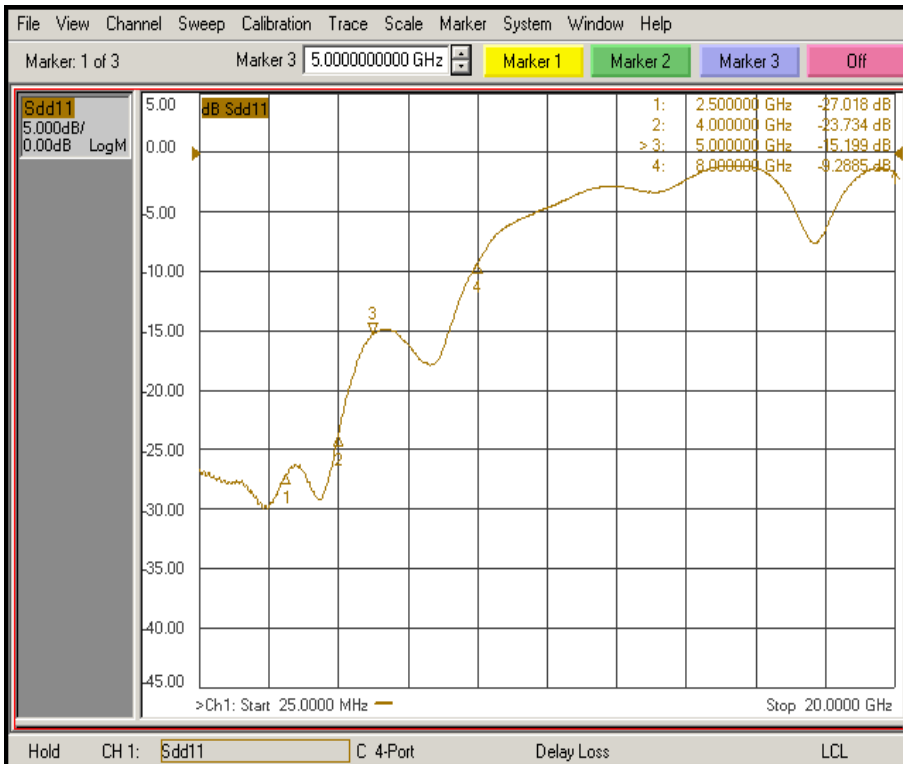

Measured Data Eye for 10.3125 Gbps Thunderbolt Path at $V_{DD} = 3.0V$, $T_A = 25^{\circ}C$, PRBS2⁷⁻¹

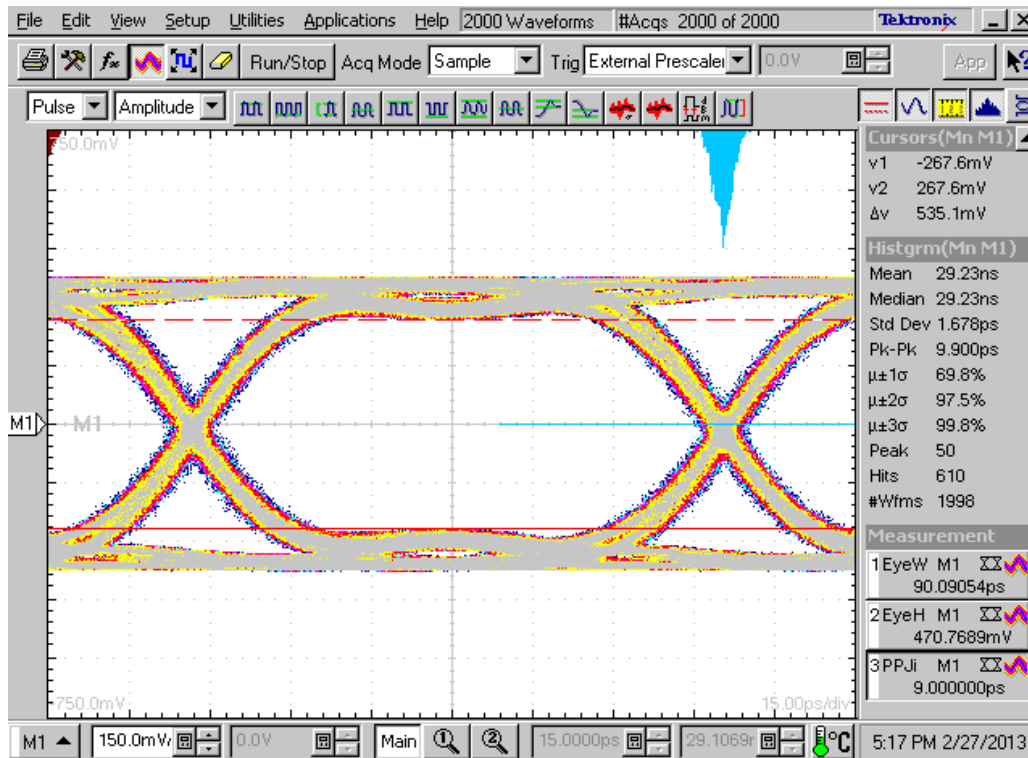

Measured Data Eye for 5.4 Gbps Display Port Path at $V_{DD} = 3.0V$, $T_A = 25^{\circ}C$, PRBS2⁷⁻¹

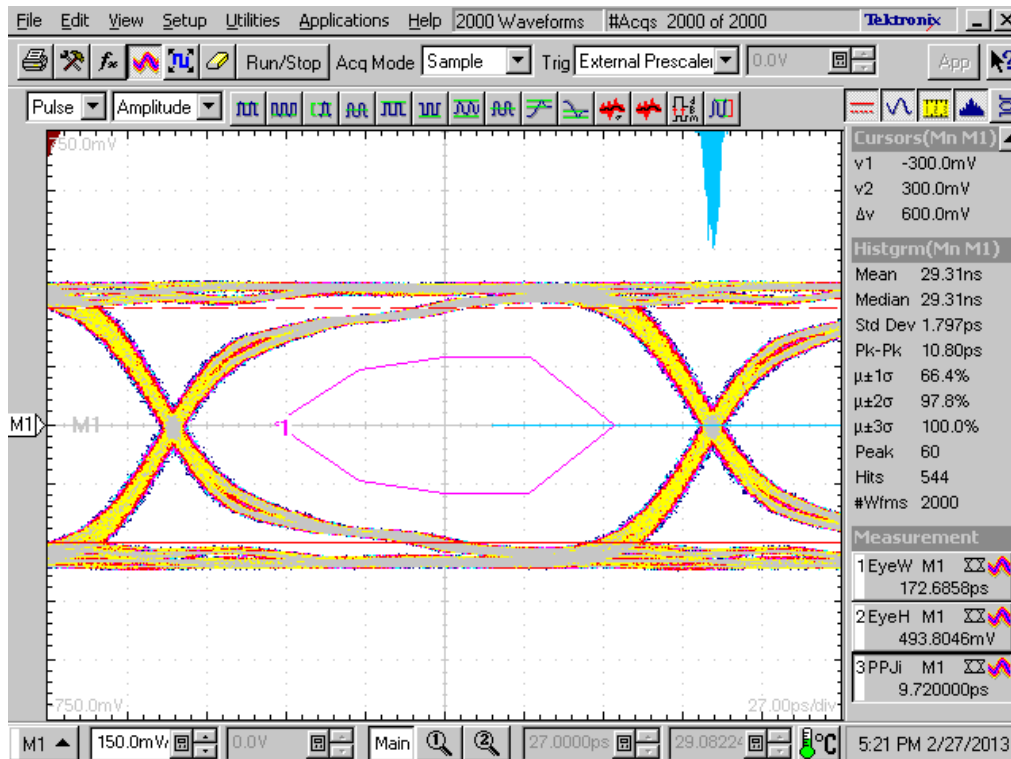

Packaging Mechanical: 24-Contact TQFN

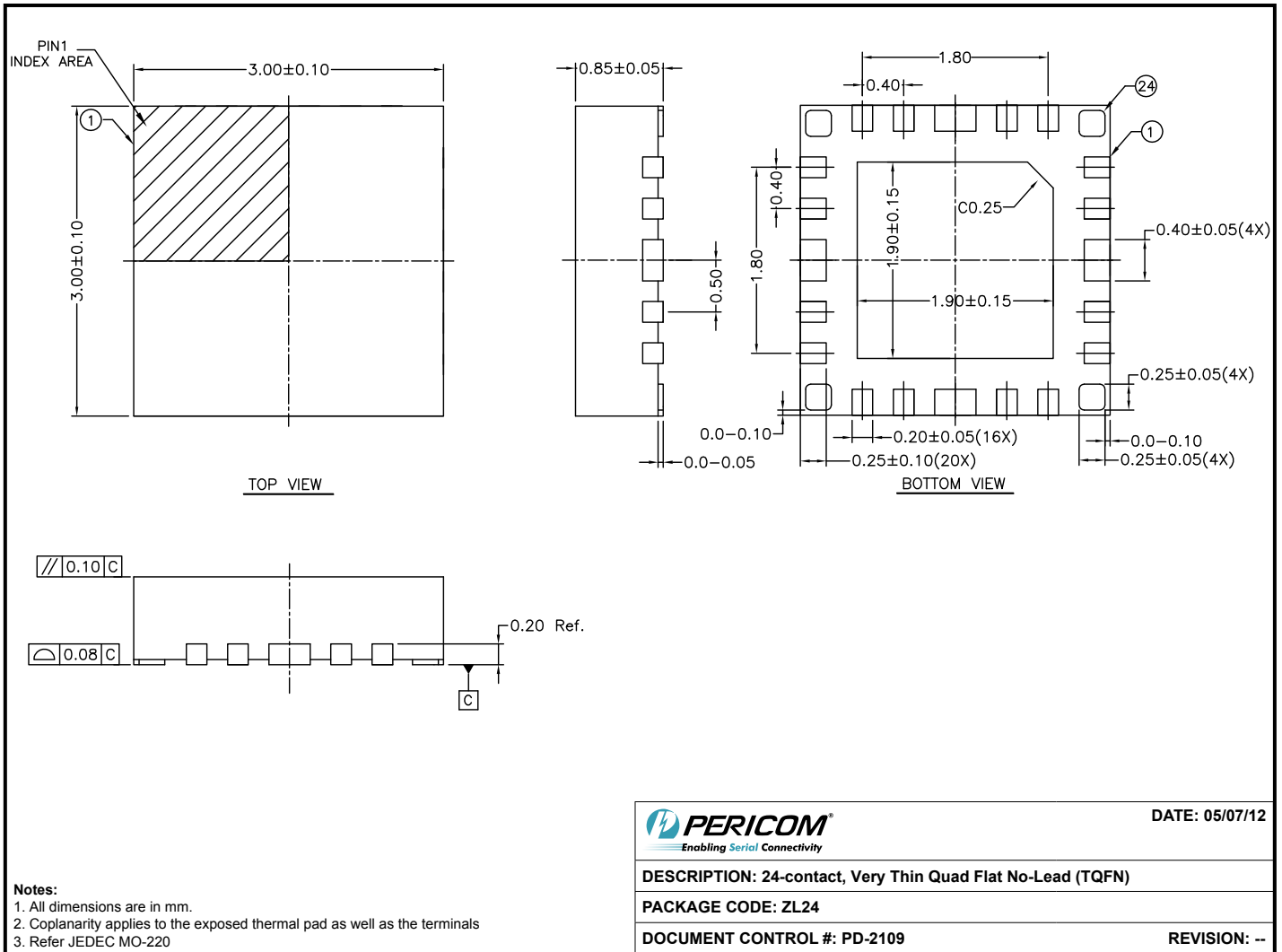

Please check for the latest package information on the Pericom web site at www.pericom.com/packaging/

Ordering Information

Ordering Number	Package Code	Package Description
PI3TB212ZLE	ZL	Pb-free & Green 24-Contact TQFN

- Thermal characteristics can be found on the company web site at www.pericom.com/packaging/
- E = Pb-free and Green
- X suffix = Tape/Reel