

**Up to 1200W, Single Output,
Medical and Industrial Power
supply**



Features	Benefits
• BF ready medical isolation (MOPP)	Eases design into systems (including BF)
• Low speed, low audible noise fan	Enhanced patient / user experience
• PMBus™ communication option	Remote monitoring and control
• 7 year warranty	Low cost of ownership

**Multiple output units available,
see TDK-Lambda's QM Series**

Standard models. Select the order code from the table below according to the required output voltage and options.

Base Unit	Voltage	Adjustment range	Max Current	Max Output power	Ripple and noise				Load regulation	Max capacitive load	Transient response	
					0-70°C		-20-0°C				deviation _a	recovery _b
					>5%load	≤5%load	>5%load	≤5%load				
QS4-600-12	12	12-13.2V	50A	600W	4%	1%	4%	2%	<1%	1000µF/A	<5%	1ms
QS4-600-24	24	24-26.4V	25A	600W	4%	1%	4%	2%	<1%	750µF/A	<5%	1ms
QS4-600-48	48	48-52.8V	12.5A	600W	4%	1%	4%	2%	<1%	250µF/A	<5%	1ms
QS5-600-12	12	12-13.2V	50A	600W	4%	1%	4%	2%	<1%	1000µF/A	<5%	1ms
QS5-600-24	24	24-26.4V	25A	600W	4%	1%	4%	2%	<1%	750µF/A	<5%	1ms
QS5-600-48	48	48-52.8V	12.5A	600W	4%	1%	4%	2%	<1%	250µF/A	<5%	1ms
QS5H-1080-12	12	12-12.8V	90A	1080W	4%	1%	4%	2%	<3.5% _c	1000µF/A	<5%	30ms
QS5H-1200-24	24	24-26.4V	50A	1200W	4%	1%	4%	2%	<1%	650µF/A	<5%	1ms
QS5H-1200-48	48	48-52.8V	25A	1200W	4%	1%	4%	2%	<1%	500µF/A	<5%	1ms
QS7-1080-12	12	12-12.8V	90A	1080W	4%	1%	4%	2%	<3.5% _c	1000µF/A	<5%	30ms
QS7-1200-24	24	24-26.4V	50A	1200W	4%	1%	4%	2%	<1%	650µF/A	<5%	1ms
QS7-1200-48	48	48-52.8V	25A	1200W	4%	1%	4%	2%	<1%	500µF/A	<5%	1ms

a - Transient deviation as a percentage of set voltage for 50% load change above 25% load.
b - For recovery to 1% of set voltage
c - for 1-100% load change

Order codes for standard models. See Standby/Signals section for details. Additional variants available - contact sales for details

Base unit	No standby	5V / 2A standby			5V / 0.25A standby	
		PMBus™ (-P5H)	Inhibit (-T5H)	Enable (-E5H)	Inhibit (-T5L)	Enable (-E5L)
QS4-600-12	QS400011	QS40002K	QS400034	QS40004N	QS400057	QS40006S
QS4-600-24	QS40007B	QS40008W	QS40009F	QS4000BD	QS4000CY	QS4000DH
QS4-600-48	QS4000FL	QS4000G5	QS4000HP	QS4000JT	QS4000KC	QS4000LX
QS5-600-12	QS5000VR	QS5000YW	QS50012N	QS50015M	QS50018X	QS5001C7
QS5-600-24	QS5000WP	QS50010M	QS50013N	QS50016P	QS50019R	QS5001D2
QS5-600-48	QS5000XN	QS50011G	QS50014G	QS50017F	QS5001B4	QS5001F8
QS5H-1080-12	QS50001M	QS5000GX	QS5000K7	QS50008F	QS5000ND	QS5000CX
QS5H-1200-24	QS50002N	QS5000HM	QS5000L6	QS50009G	QS5000PG	QS5000DY
QS5H-1200-48	QS500047	QS5000JP	QS5000M5	QS5000BW	QS5000RF	QS5000FY
QS7-1080-12	QS70001G	QS70008D	QS7000C5	QS7000GW	QS7000KY	QS7000NR
QS7-1200-24	QS700029	QS70009B	QS7000DL	QS7000HV	QS7000LS	QS7000PP
QS7-1200-48	QS70004B	QS7000BK	QS7000FM	QS7000JT	QS7000M0	QS7000RN

Input	
Input voltage	90-264Vac. QS5H limited to 700W output power below 180Vac input, QS4 limited to 550W below 180Vac input.
Frequency	47 - 63 Hz (440Hz with reduced PFC)
Input fuses	25A (QS5 = 16A) / 250Vac, HBC Fast acting (not user accessible) in both Live and Neutral lines (single fusing optional)
Inrush current	QS5 & QS5H <40A, QS7 <45A at 25°C and 264Vac (cold start)
Leakage current	<300µA
Touch current	<100µA
Power factor	> 0.95 (at 230Vac, 100% load)

Isolation		
Input to output / signals	Reinforced	2 x MOPPs (3rd edition 60601) 4kVac, 5.7kVdc type tested to 4kVac (equivalent to 5.7kVdc), production tested to 4.3kVdc.
Input to earth	Basic	1 x MOPP, 1.5kVac
Output / signals to earth	Basic	1 x MOPP, 1.5kVac
Output / signals to output / signals	Basic	200Vdc

Output Specification	QS4/5/5H	QS7	
Turn on time	2s max		at 90Vac and 100% rated output power
Efficiency	up to 91%		240Vac & above 50% rated power, configuration dependent
Minimum hold up	10ms	20ms	at maximum output power.
Standard signals	Output good, output inhibit		
Rise time	<75ms		(with resistive load) to 90% of voltage, monotonic rise above 10%
Turn on overshoot	<5%		Load type dependent
Voltage setting accuracy	<1%		of set voltage
Remote sense	Yes		0.5V (voltage at the output terminals must remain within the adjustment range specified above)
Minimum load	0W		
Temperature coefficient	0.016%		of rated voltage per °C
Line regulation	<0.1%		for 90-264Vac input change
Over voltage protection	Yes		Latching, module shuts down, cycle ac to restart.
Over current protection	Hiccup		Auto recovers
Short circuit protection	Yes		Indefinitely protected
Over temperature protection	Yes		Primary side protection shuts down main output and fan, auto restarts. Secondary side protection shuts down main output, cycle ac to restart. Shutdown temperature varies according to ambient, output power and input voltage.

Environment	
Temperature	-20°C to 70°C operational, -40°C to 70°C storage.
Derating	50°C to 70°C derate total output power and each output current by 2.5% per °C Additionally, the 0.25A standby supply provided with the E5H, E12H, T5H and T12H options derates by 2.4% per °C from 25°C to 50°C when the unit is inhibited (fan not running)
Low temperature startup	-40°C
Humidity	5 - 95% RH non condensing
Shock	±3 x 30g shocks in each plane, total 18 shocks (11ms (+/-0.5msec), half sine) Conforms to EN60068-2-27, EN60068-2-47, IEC68-2-27, IEC68-2-47, JIS C0041-1987. Conforms to MIL-STD-810G, Method 516.6, Pro IV
Vibration	Single axis 10 - 500 Hz at 2g (sweep and endurance at resonance) in all 3 planes Conforms to EN60068-2-6, IEC68-2-6 Conforms to MIL-STD-810G, Method 514.6, Pro I
Altitude	5000 metres operational, 5000 metres storage/transportation
Pollution	Degree 2, Material group IIIb
IP Rating	IPX0

Immunity EN61000-6-2:2005, EN60601-1-2:2015 - see application notes for best installation practice					Criteria
Electrostatic discharge	EN61000-4-2	Level 4	F type cooling only		A
Electromagnetic field	EN61000-4-3	Level 3	Proximity fields, EN60601-1-2, Levels as defined in standard, Criteria A		A
Fast / burst transient	EN61000-4-4	Level 4	Tested at 5kHz and 100kHz		A
Surge immunity	EN61000-4-5	Level 3			A
Conducted RF immunity	EN61000-4-6	Level 3			A
Power frequency magnetic field	EN61000-4-8	Level 4			A
Voltage dips, variations, interruptions	EN61000-4-11	Class 3	Criteria B for 5s and 1 cycle interruptions		A
Voltage sags	Semi F-47	compliant	above 180Vac input		
Ring wave	EN61000-4-12	Level 3			A
	ANSI C62.41	3kV	30Ω Neutral Grounding (0.5μs-100kHz Ring Wave)		A
Voltage fluctuations	EN61000-4-14	Class 3	See EMC report for full details.		A

Emissions EN61000-6-3:2007, EN60601-1-2:2015 - see application notes for best installation practice				
Radiated electric field	EN55011, EN55032	(as per CISPR.11/32) Class B, FCC47 part 15 subpart B - 'L' leakage current variants (Units with 'R' type leakage current option achieve Class A)		
Conducted emissions	EN55011, EN55032	(as per CISPR.11/32) Class B, FCC47 part 15 subpart B - 'L' leakage current variants (Units with 'R' type leakage current option achieve Class A)		
Conducted harmonics	EN61000-3-2	Class A and Class C		
Flicker	EN61000-3-3	Compliant - d _{max} only		

Approvals / Accreditations	
IEC/EN 62368-1, UL62368-1 / CSA 22.2 No 62368-1	File E135494
IEC/EN 60950-1, UL60950-1 / CSA 22.2 No 60950-1	File E135494
IEC/EN 60601-1, UL/CSA 60601-1, ANSI/AAMI ES60601-1, CAN/CSA-C22.2 No 60601-1	File E349607
IEC/EN 61010-1	Designed to meet
CE Mark (EN62368-1)	Low Voltage Directive (LVD), electromagnetic compatibility (EMC) and Restriction of Hazardous Substances (RoHS)
CB certificate and Report available on request	
Designed and manufactured under the control of ISO9001 and ISO13485 (including risk management).	

Other variants (input connection, cooling, etc)

The standard models listed are supplied with 'F' cooling, Screw terminal inputs and outputs, dual ac fuses and 300μA earth leakage current. Other options are possible by selecting from the table below.

Case size	QS4	↑	
	QS5		
	QS5H		
	QS7		
Output power	600	↑	
	1080		
	1200		
Output voltage	12	↑	
	24		
	48		
Output Connection	blank	↑	
	Screw		
Standby / Signals	blank	none	↑
	-E5L	5V / 250mA, Enable	
	-E5H	5V / 2A, 5V / 250mA, Enable	
	-T5L	5V / 250mA, Inhibit	
	-T5H	5V / 2A, 5V / 250mA, Inhibit	
-P5H	5V / 2A, see PMBus™ app note		

see specification page for details

QS7-	1200-	24		-T5H
------	-------	----	--	------

Unit options blank for all defaults or all of

-Cooling	Input	Fuse	Leakage
-F	S	D	L

Cooling	F	Variable speed Forward air
---------	---	----------------------------

Input Connection	S	Screw (default)
	I	IEC320 (QS5 and QS5H only)

Input fuse	D	Dual AC fuses
------------	---	---------------

Leakage Current (max at 264Vac, 63Hz)	L	300μA
---------------------------------------	---	-------

Contact TDK-Lambda to validate configuration and issue a part number.

Standby / Signals

Maximum power per channel	See table below
Available signals (Exx or Txx type)	PSU inhibit (Txx type) or enable (Exx type), AC Good
Available signals (Pxx type)	PMBus™ control of power supply fan speed and fail warning Serial number, date of manufacture, run time, on/off power cycles For further details, see the product range application notes, PMBus™ section
Additional Leakage Current (max at 264Vac, 63Hz)	xxL = 13.1µA, xxH = 15µA Must also add the leakage current from modules and selected filter option.

Available Output Voltages (at PSU signal connector)

Option type	Standby 1			Standby 2			PSU on/off
	V	Max Current	Power	V	Max Current	Power	
E5L	5V	250mA	1.25W	not available			Enable
E5H	5V	250mA	1.25W	5V	2A	10W	Enable
T5L	5V	250mA	1.25W	not available			Inhibit
T5H	5V	250mA	1.25W	5V	2A	10W	Inhibit
P5H	5V	2A	10W	not available			see PMBus™ application note

Txx or Exx option		
Pin	5L	5H
1	Do not connect	Standby 2 +
2	Do not connect	Standby 2 -
3	Standby 1 +	Standby 1 +
4	Standby 1 -	Standby 1 -
5	PSU on/off+	PSU on/off+
6	PSU on/off-	PSU on/off-
7	AC fail Out	AC fail Out
8	AC fail Rtn	AC fail Rtn
9	Do not connect	
10	Do not connect	

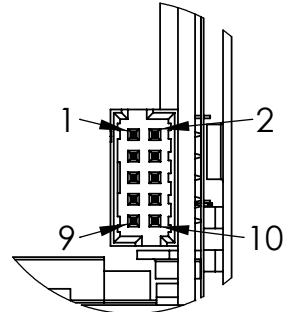

Pin	P5H or P12H option
1	Standby +
2	Standby -
3	Do not connect
4	Fan fail
5	Address 0
6	Address 1
7	Address 2
8	Address 3
9	SCL - Clock
10	SDA - Data
11	Control line in
12	GND

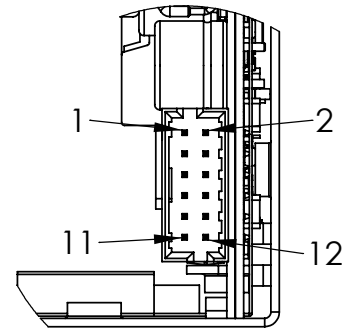

Output Specification

	Standby 1	Standby 2
Rise time	<30ms	(with resistive load) to 90% of voltage, monotonic rise above 10%
Ripple and noise	<1%	pk-pk, using 20MHz bandwidth
Voltage setting accuracy	<3%	of set voltage
Remote sense	No	
Minimum load	0W	on any output
Temperature coefficient	0.02%	of rated voltage per °C
Load regulation	<1.5%	<1%
Line regulation	<0.1%	for 90-264Vac input change
Cross regulation	<0.4%	for 100% load change on any output
Transient deviation	<5%	of set voltage for 25-50% load change
Recovery	1ms	for recovery to 1% or 100mV of set voltage
Over voltage protection	Yes	Latching, output shuts down, cycle ac to reset
Over current protection	Constant Current	Auto recovers
Short circuit protection	Constant Current	Auto recovers

Output connections

QS4-600-x and QS5-600-x

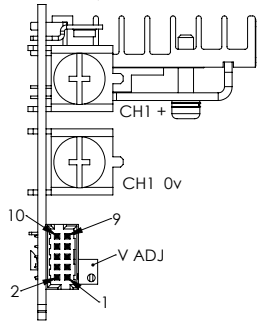

QS5H-1200-x and QS7-1200-x

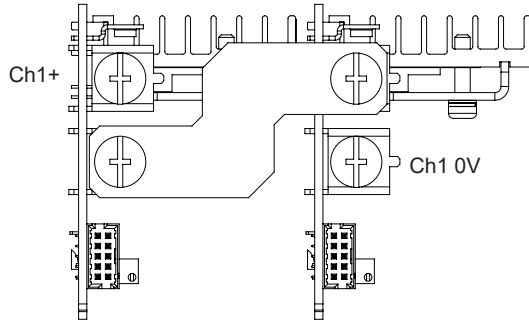

QS5H-1080-12 and QS7-1080-12

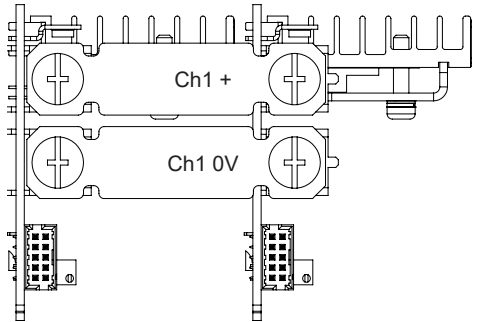

See application notes for signal connection details

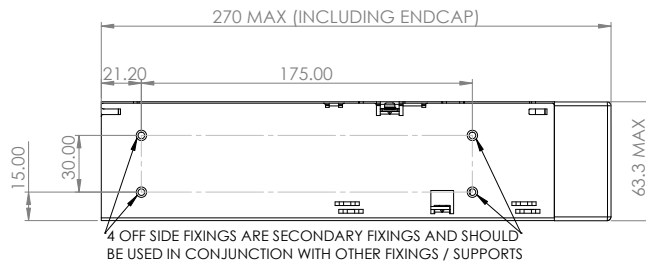

4 OFF SIDE FIXINGS ARE SECONDARY FIXINGS AND SHOULD BE USED IN CONJUNCTION WITH OTHER FIXINGS / SUPPORTS

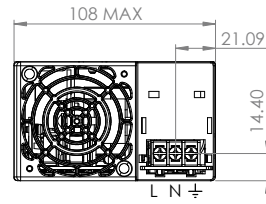

TERMINAL COVER REMOVED

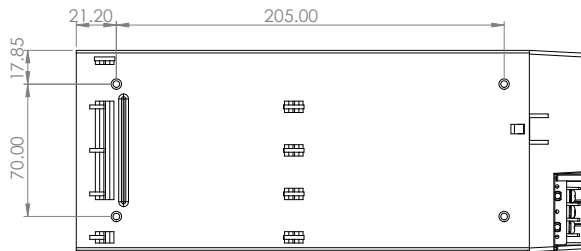

Customer Fixings.
8 holes M4.
Max thread penetration:- 4.5mm

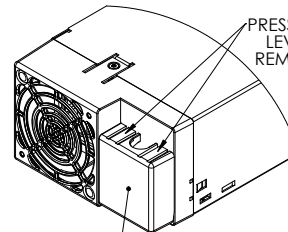

ACCESS TO SCREW TERMINALS BY REMOVING COVER

QS4 Units with factory fitted fan ('F' or 'R' type cooling)

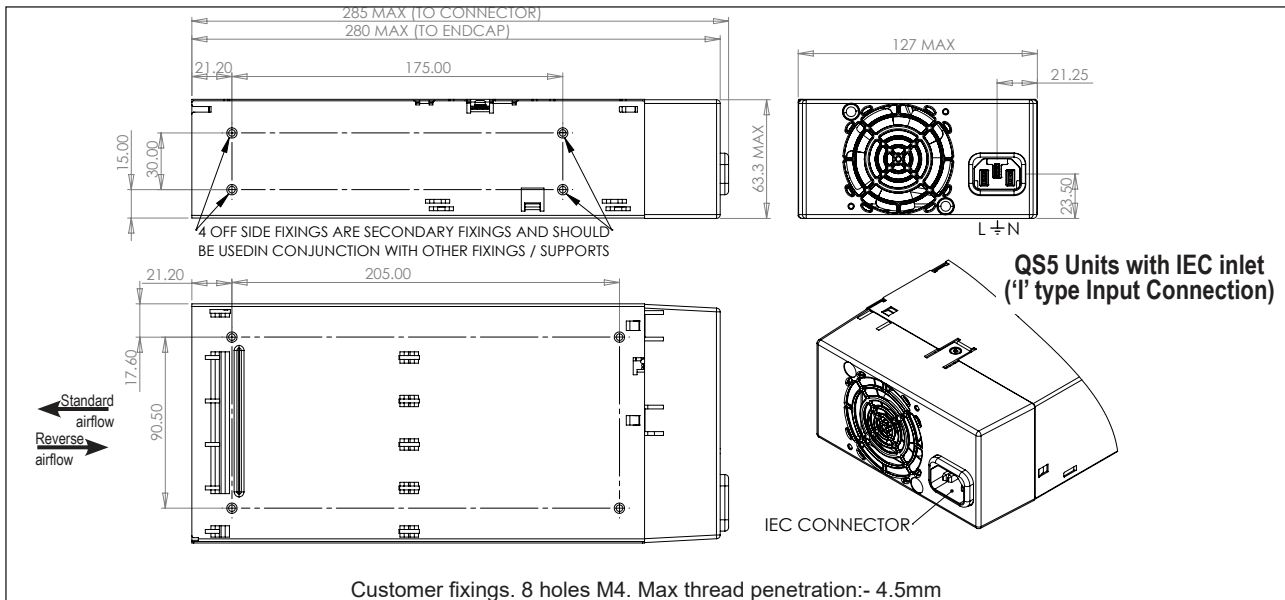
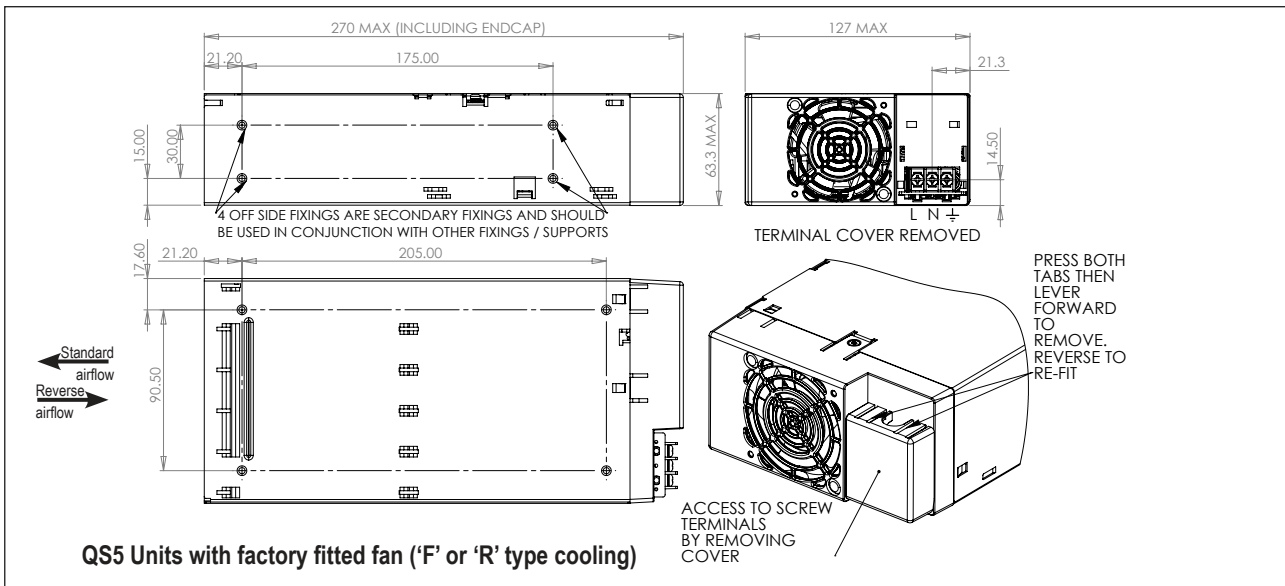
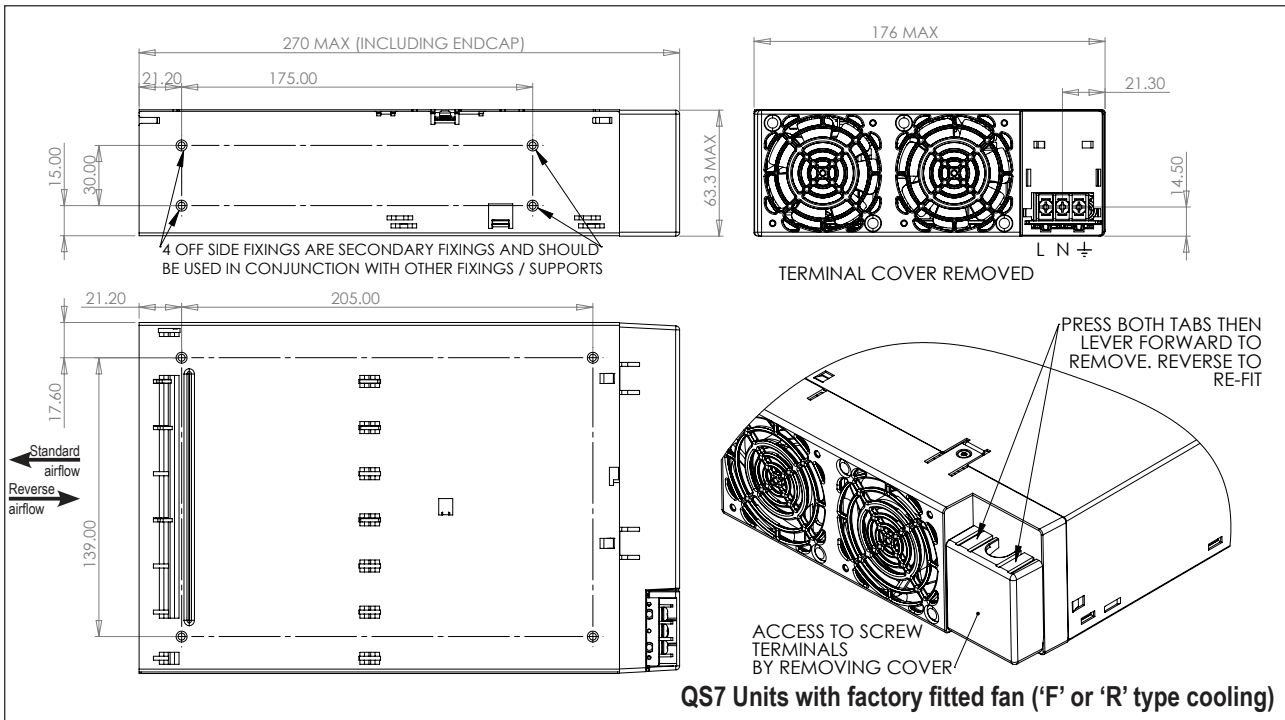



TDK-Lambda France SAS

Tel: +33 1 60 12 71 65
france@fr.tdk-lambda.com
www.emea.lambda.tdk.com/fr



Italy Sales Office

Tel: +39 02 61 29 38 63
info.italia@it.tdk-lambda.com
www.emea.lambda.tdk.com/it



Netherlands

info@nl.tdk-lambda.com
www.emea.lambda.tdk.com/nl



TDK-Lambda Germany GmbH

Tel: +49 7841 666 0
info.germany@de.tdk-lambda.com
www.emea.lambda.tdk.com/de



Austria Sales Office

Tel: +43 2256 655 84
info@at.tdk-lambda.com
www.emea.lambda.tdk.com/at



Switzerland Sales Office

Tel: +41 44 850 53 53
info@ch.tdk-lambda.com
www.emea.lambda.tdk.com/ch



Nordic Sales Office

Tel: +45 8853 8086
info@dk.tdk-lambda.com
www.emea.lambda.tdk.com/dk



TDK-Lambda UK Ltd.

Tel: +44 (0) 12 71 85 66 66
powersolutions@uk.tdk-lambda.com
www.emea.lambda.tdk.com/uk



TDK-Lambda Ltd.

Tel: +9 723 902 4333
info@tdk-lambda.co.il
www.emea.lambda.tdk.com/il



C.I.S.

Commercial Support:

Tel: +7 (495) 665 2627

Technical Support:

Tel: +7 (812) 658 0463

info@tdk-lambda.ru
www.emea.lambda.tdk.com/ru



TDK-Lambda Americas

Tel: +1 800-LAMBDA-4 or 1-800-526-2324
powersolutions@us.tdk-lambda.com
www.us.lambda.tdk.com



TDK Electronics do Brasil Ltda

Tel: +55 11 3289-9599
sales.br@tdk-electronics.tdk.com
www.tdk-electronics.tdk.com/en



TDK-Lambda Corporation

Tel: +81-3-6778-1113
www.jp.lambda.tdk.com



TDK-Lambda (China) Electronics Co. Ltd.

Tel: +86 21 6485-0777
powersolutions@cn.tdk-lambda.com
www.lambda.tdk.com.cn



TDK-Lambda Singapore Pte Ltd.

Tel: +65 6251 7211
tfs.mkt@sg.tdk-lambda.com
www.sg.lambda.tdk.com



TDK India Private Limited, Power Supply Division

Tel: +91 80 4039-0660
mathew.philip@in.tdk-lambda.com
www.sg.lambda.tdk.com

