



## STD35N3LH5

N-channel 30 V, 12.5 m $\Omega$  35 A, DPAK  
STripFET™ V Power MOSFET

### Features

Order code	V <sub>DSS</sub>	R <sub>DS(on)</sub> max	I <sub>D</sub>
STD35N3LH5	30 V	< 16 m $\Omega$	35 A

- 100% avalanche tested
- Surface mounting DPAK (TO-252)
- Low gate drive power losses

### Applications

- Switching applications
  - Automotive

### Description

The STD35N3LH5 is a N-channel STripFET™ V. This Power MOSFET technology is among the latest improvements, which have been especially tailored to achieve very low on-state resistance providing also one of the best-in-class figure of merit (FOM).

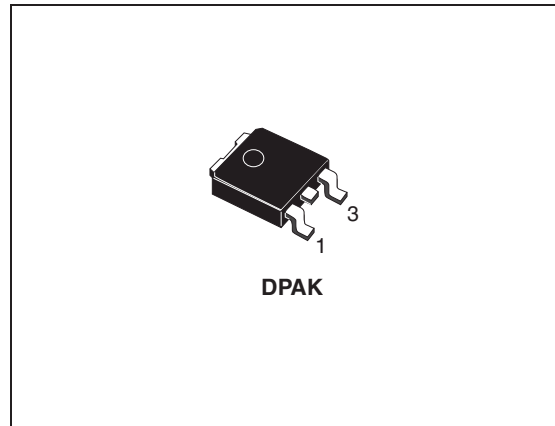
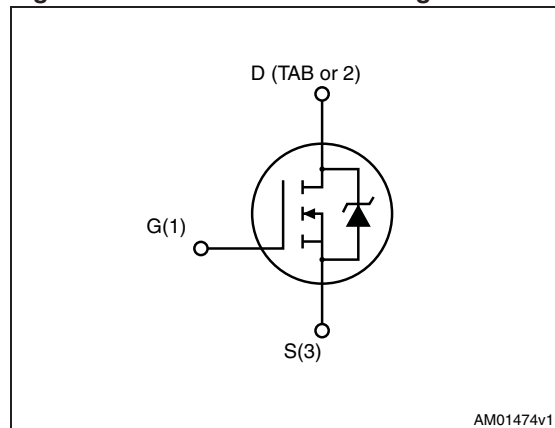

Figure 1. Internal schematic diagram



AM01474v1

Table 1. Device summary

Order code	Marking	Package	Packaging
STD35N3LH5	D35N3LH5	DPAK	Tape and reel

---

# Contents

<b>1</b>	<b>Electrical ratings</b> .....	<b>3</b>
<b>2</b>	<b>Electrical characteristics</b> .....	<b>4</b>
	2.1 Electrical characteristics (curves) .....	6
<b>3</b>	<b>Test circuits</b> .....	<b>8</b>
<b>4</b>	<b>Package mechanical data</b> .....	<b>9</b>
<b>5</b>	<b>Packaging mechanical data</b> .....	<b>10</b>
<b>6</b>	<b>Revision history</b> .....	<b>11</b>

# 1 Electrical ratings

**Table 2. Absolute maximum ratings**

Symbol	Parameter	Value	Unit
$V_{DS}$	Drain-source voltage ( $V_{GS}=0$ )	30	V
$V_{GS}$	Gate-source voltage	$\pm 20$	V
$I_D^{(1)}$	Drain current (continuous) at $T_C = 25\text{ }^\circ\text{C}$	35	A
$I_D$	Drain current (continuous) at $T_C = 100\text{ }^\circ\text{C}$	22	A
$I_{DM}^{(2)}$	Drain current (pulsed)	140	A
$P_{TOT}$	Total dissipation at $T_C = 25\text{ }^\circ\text{C}$	35	W
$T_j$ $T_{stg}$	Operating junction temperature Storage temperature	-55 to 175	$^\circ\text{C}$

1. The value is rated according  $R_{thj-c}$
2. Pulse is rated according safe operating area

**Table 3. Thermal resistance**

Symbol	Parameter	Value	Unit
$R_{thj-case}$	Thermal resistance junction-case max	4.3	$^\circ\text{C/W}$
$R_{thj-pcb}^{(1)}$	Thermal resistance junction-ambient max	50	$^\circ\text{C/W}$

1. When mounted on 1 inch<sup>2</sup> FR-4 2Oz Cu board

**Table 4. Avalanche data**

Symbol	Parameter	Value	Unit
$I_{AV}$	Not-repetitive avalanche current	14	A
$E_{AS}$	Single pulse avalanche energy (starting $T_J = 25\text{ }^\circ\text{C}$ , $I_D = I_{AV}$ , $V_{DD} = 24\text{ V}$ )	100	mJ

## 2 Electrical characteristics

(T<sub>CASE</sub> = 25 °C unless otherwise specified)

**Table 5. Static**

Symbol	Parameter	Test conditions	Min.	Typ.	Max.	Unit
V <sub>(BR)DSS</sub>	Drain-source breakdown voltage	I <sub>D</sub> = 250 μA, V <sub>GS</sub> = 0	30			V
I <sub>DSS</sub>	Zero gate voltage drain current (V <sub>GS</sub> = 0)	V <sub>DS</sub> = Max rating, V <sub>DS</sub> = Max rating, T <sub>c</sub> = 125 °C			1 10	μA μA
I <sub>GSS</sub>	Gate body leakage current (V <sub>DS</sub> = 0)	V <sub>GS</sub> = ±20 V			±100	nA
V <sub>GS(th)</sub>	Gate threshold voltage	V <sub>DS</sub> = V <sub>GS</sub> , I <sub>D</sub> = 250 μA	1		2.5	V
R <sub>DS(on)</sub>	Static drain-source on resistance	V <sub>GS</sub> = 10 V, I <sub>D</sub> = 15 A V <sub>GS</sub> = 4.5 V, I <sub>D</sub> = 15 A		12.5 18	16 20	mΩ mΩ

**Table 6. Dynamic**

Symbol	Parameter	Test conditions	Min	Typ.	Max.	Unit
C <sub>iss</sub>	Input capacitance	V <sub>DS</sub> = 27.5 V, f = 1 MHz, V <sub>GS</sub> = 0	-	713	-	pF
C <sub>oss</sub>	Output capacitance			135		pF
C <sub>rss</sub>	Reverse transfer capacitance			22		pF
Q <sub>g</sub>	Total gate charge	V <sub>DD</sub> = 15 V, I <sub>D</sub> = 19 A	-	5.4	-	nC
Q <sub>gs</sub>	Gate-source charge	V <sub>GS</sub> = 4.5 V		2		nC
Q <sub>gd</sub>	Gate-drain charge	<a href="#">Figure 14</a>		2.1		nC
R <sub>G</sub>	Intrinsic gate resistance	f = 1 MHz open drain	-	3.3	-	Ω

**Table 7. Switching on/off (inductive load)**

Symbol	Parameter	Test conditions	Min.	Typ.	Max.	Unit
$t_{d(on)}$ $t_r$	Turn-on delay time Rise time	$V_{DD}=15\text{ V}$ , $I_D=5.5\text{ A}$ , $R_G=4.7\ \Omega$ , $V_{GS}=10\text{ V}$ <i>Figure 16</i>	-	4 4	-	ns ns
$t_{d(off)}$ $t_f$	Turn-off delay time Fall time		-	20 3.5	-	ns ns

**Table 8. Source drain diode**

Symbol	Parameter	Test conditions	Min.	Typ.	Max.	Unit
$I_{SD}$ $I_{SDM}^{(1)}$	Source-drain current Source-drain current (pulsed)		-		35 140	A A
$V_{SD}^{(2)}$	Forward on voltage	$I_{SD}=35\text{ A}$ , $V_{GS}=0$	-		1.5	V
$t_{rr}$ $Q_{rr}$ $I_{RRM}$	Reverse recovery time Reverse recovery charge Reverse recovery current	$I_{SD}=11\text{ A}$ , $di/dt=100\text{ A}/\mu\text{s}$ , $V_{DD}=24\text{ V}$ , $T_j=150\text{ }^\circ\text{C}$ <i>Figure 15</i>	-	20 10.5 1		ns nC A

1. Pulse width limited by safe operating area
2. Pulsed: pulse duration = 300  $\mu\text{s}$ , duty cycle 1.5%

## 2.1 Electrical characteristics (curves)

Figure 2. Safe operating area

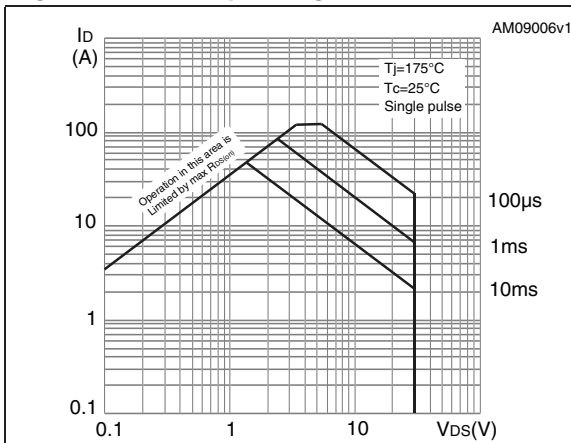

Figure 3. Thermal impedance

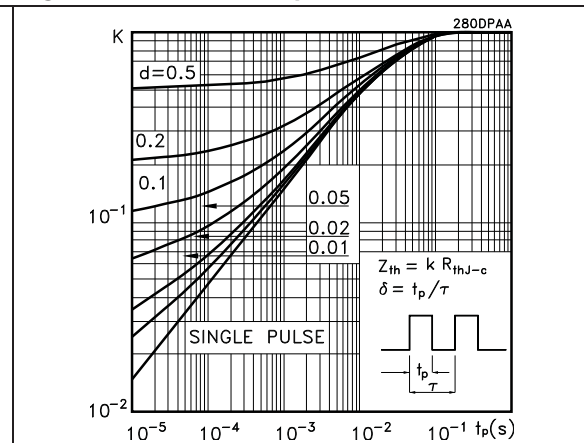

Figure 4. Output characteristics

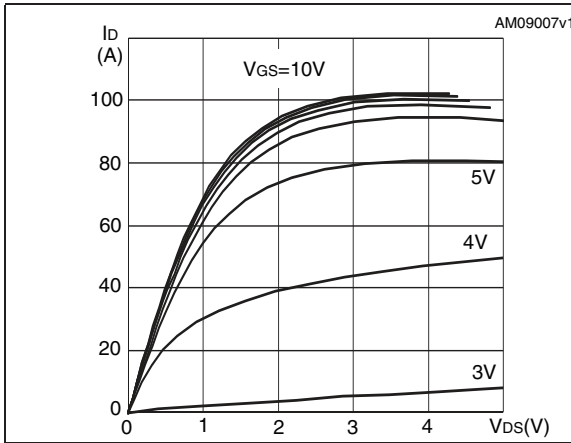

Figure 5. Transfer characteristics

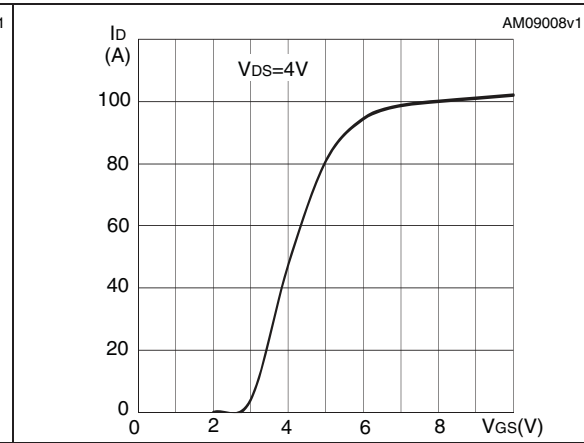

Figure 6. Normalized  $B_{V_{DSS}}$  vs temperature

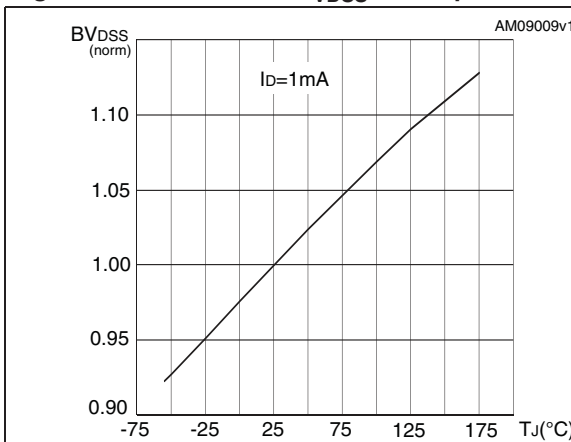

Figure 7. Static drain-source on resistance

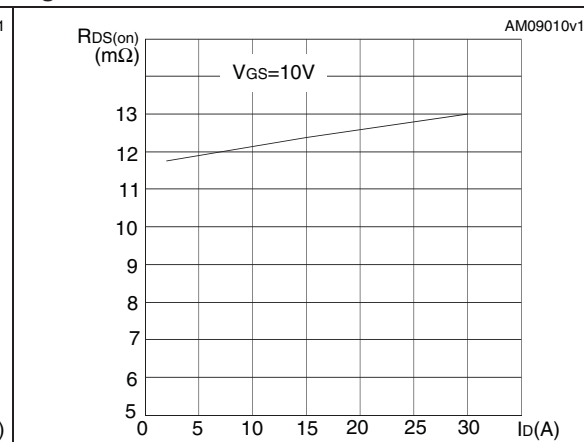

Figure 8. Gate charge vs gate-source voltage Figure 9. Capacitance variations

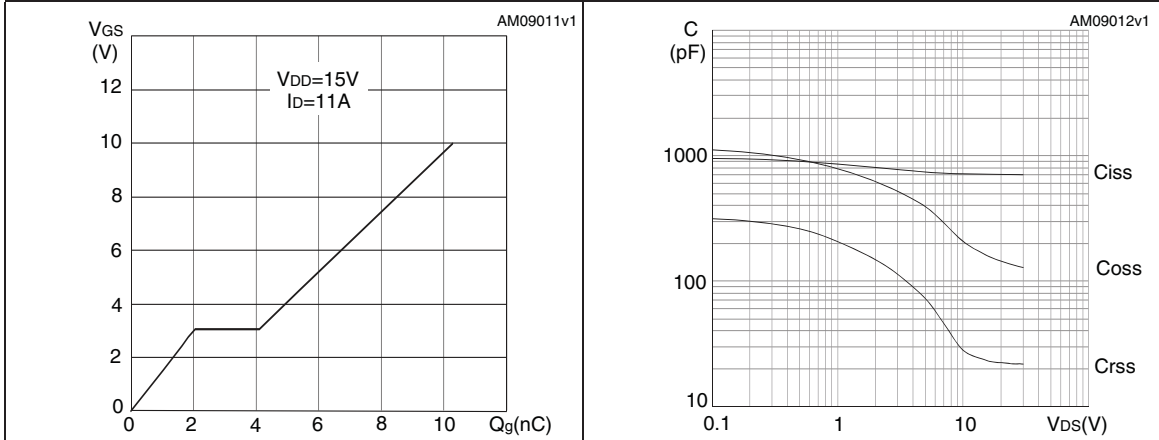

Figure 10. Normalized gate threshold voltage vs temperature Figure 11. Normalized on resistance vs temperature

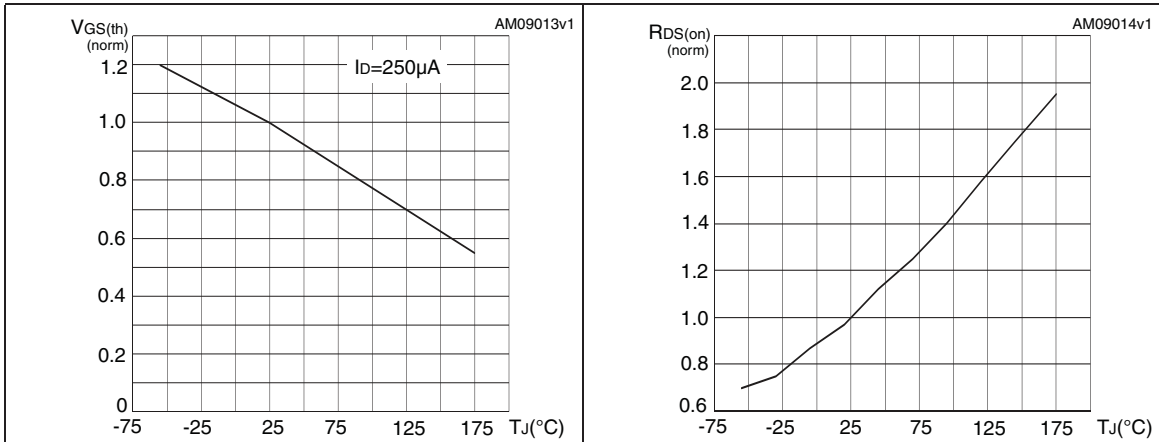
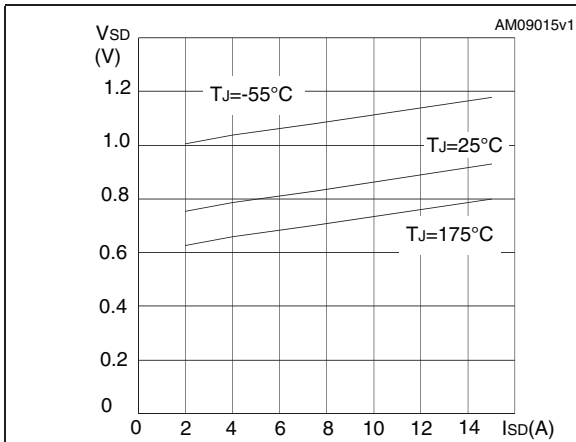

Figure 12. Source-drain diode forward characteristics



### 3 Test circuits

Figure 13. Switching times test circuit for resistive load

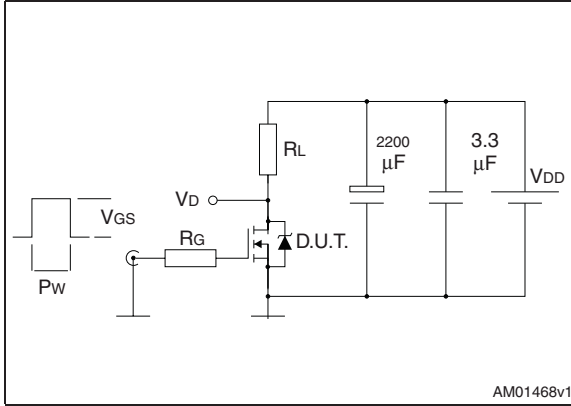

Figure 14. Gate charge test circuit

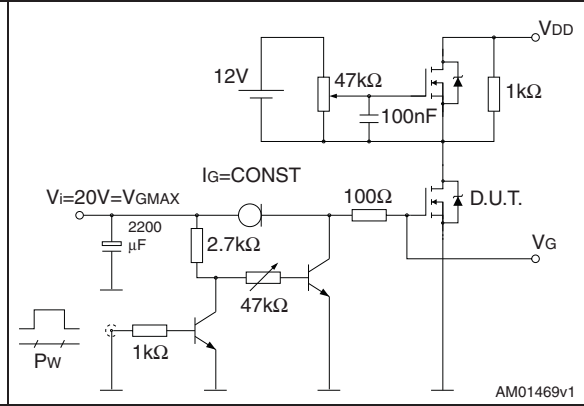

Figure 15. Test circuit for inductive load switching and diode recovery times

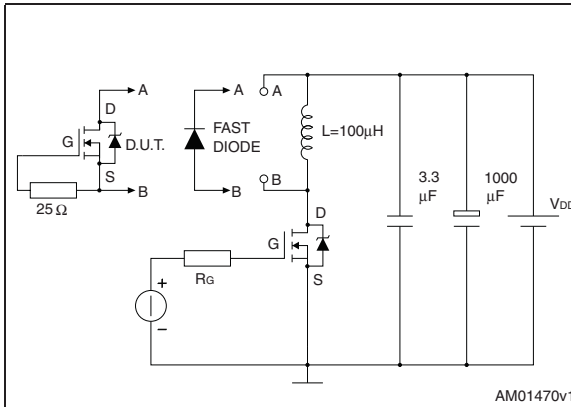

Figure 16. Unclamped inductive load test circuit

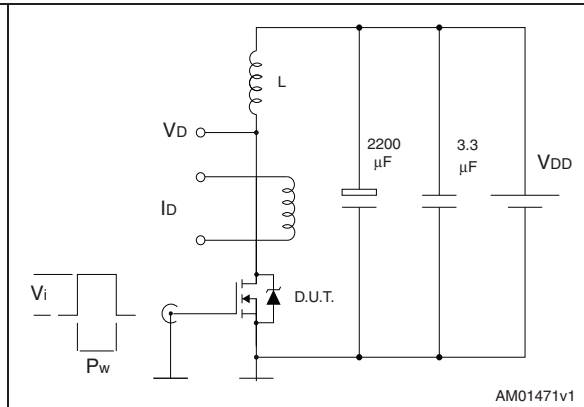

Figure 17. Unclamped inductive waveform

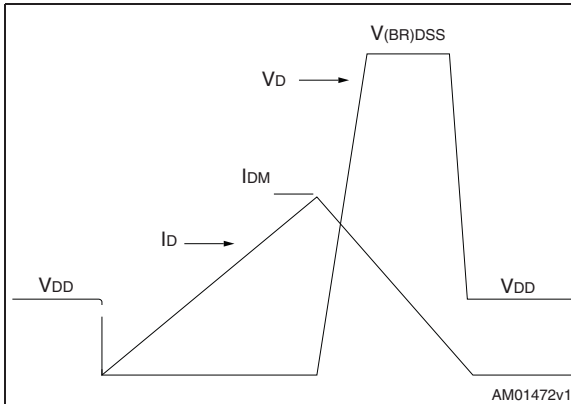
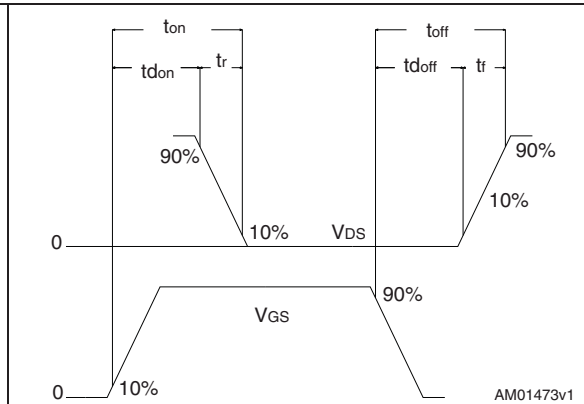

Figure 18. Switching time waveform





## 4 Package mechanical data

In order to meet environmental requirements, ST offers these devices in different grades of ECOPACK<sup>®</sup> packages, depending on their level of environmental compliance. ECOPACK<sup>®</sup> specifications, grade definitions and product status are available at: [www.st.com](http://www.st.com). ECOPACK is an ST trademark.

Table 9. DPAK (TO-252) mechanical data

Dim.	mm		
	Min.	Typ.	Max.
A	2.20		2.40
A1	0.90		1.10
A2	0.03		0.23
b	0.64		0.90
b4	5.20		5.40
c	0.45		0.60
c2	0.48		0.60
D	6.00		6.20
D1		5.10	
E	6.40		6.60
E1		4.70	
e		2.28	
e1	4.40		4.60
H	9.35		10.10
L	1		1.50
L1		2.80	
L2		0.80	
L4	0.60		1
R		0.20	
V2	0°		8°

Figure 19. DPAK footprint<sup>(a)</sup>

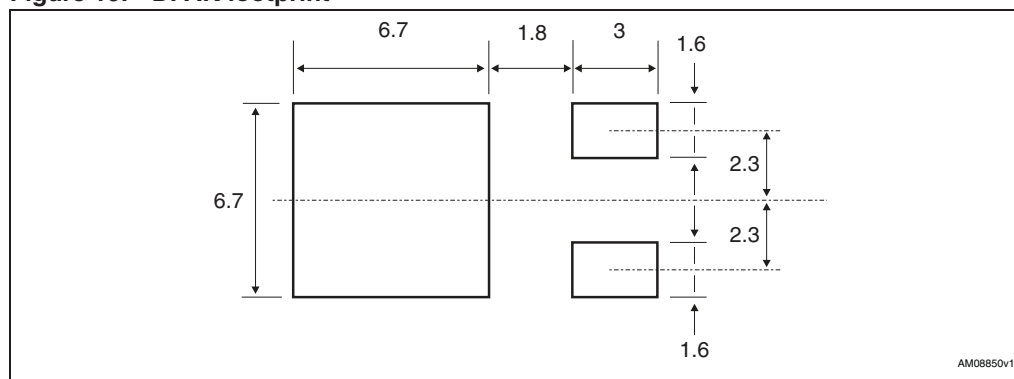

a. All dimension are in millimeters

Figure 20. DPAK (TO-252) drawing

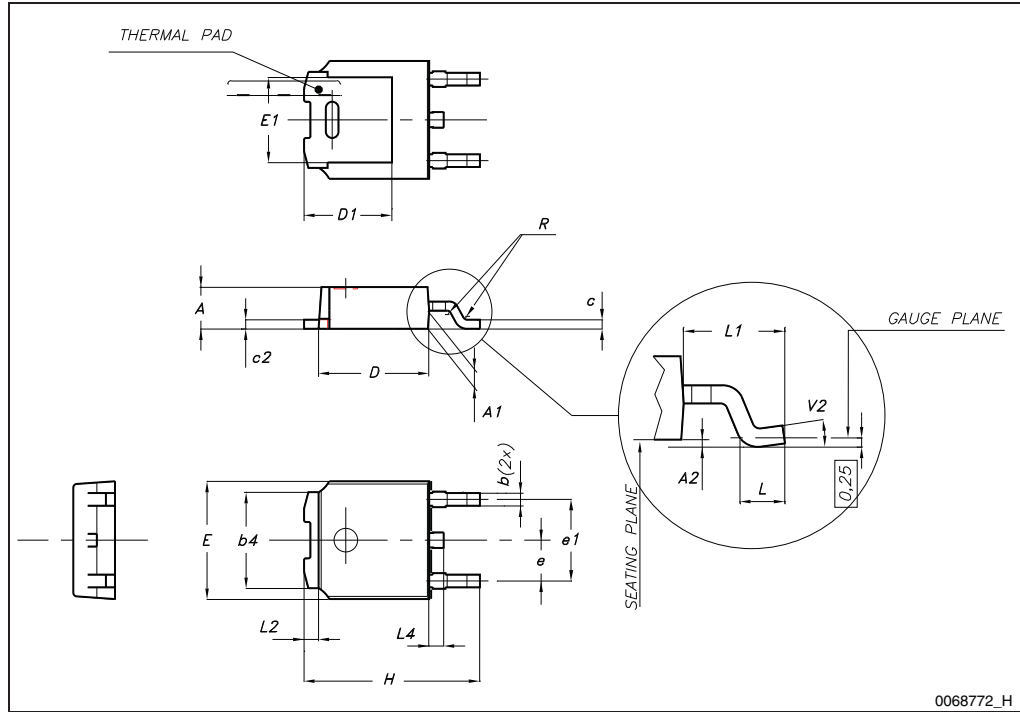

## 5 Packaging mechanical data

Table 10. DPAK (TO-252) tape and reel mechanical data

Tape			Reel		
Dim.	mm		Dim.	mm	
	Min.	Max.		Min.	Max.
A0	6.8	7	A		330
B0	10.4	10.6	B	1.5	
B1		12.1	C	12.8	13.2
D	1.5	1.6	D	20.2	
D1	1.5		G	16.4	18.4
E	1.65	1.85	N	50	
F	7.4	7.6	T		22.4
K0	2.55	2.75			
P0	3.9	4.1		Base qty.	2500
P1	7.9	8.1		Bulk qty.	2500
P2	1.9	2.1			
R	40				
T	0.25	0.35			
W	15.7	16.3			

Figure 21. Tape for DPAK (TO-252)

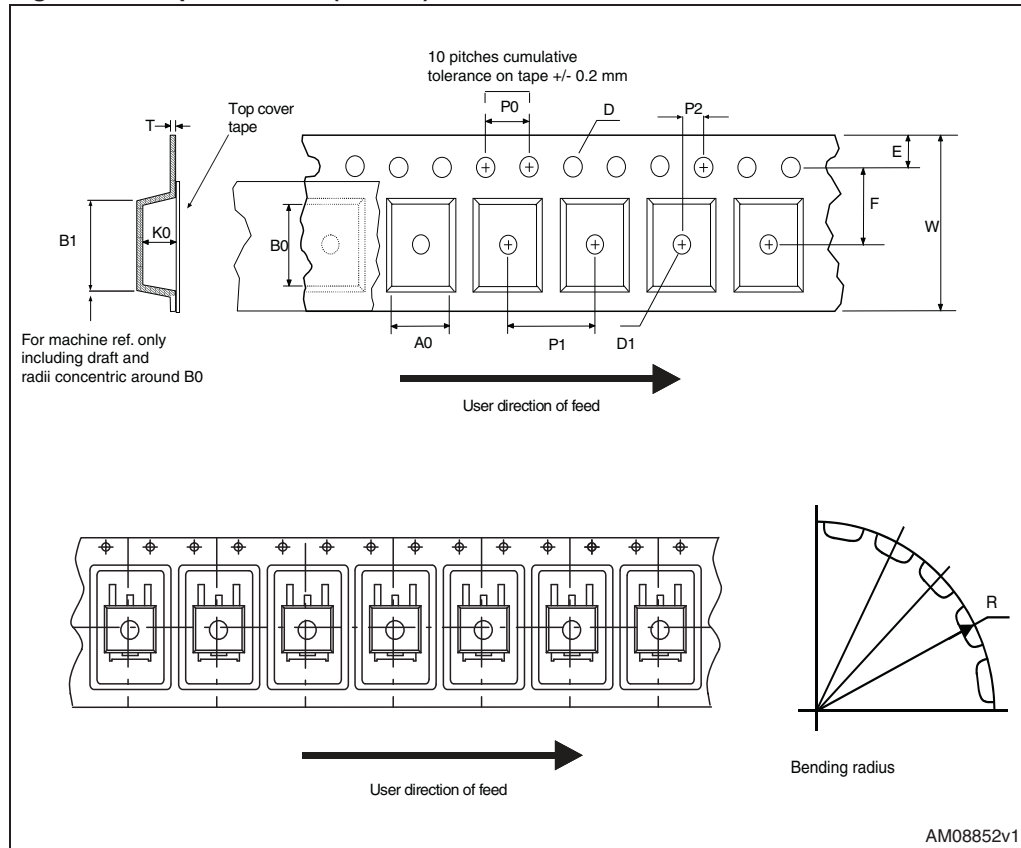
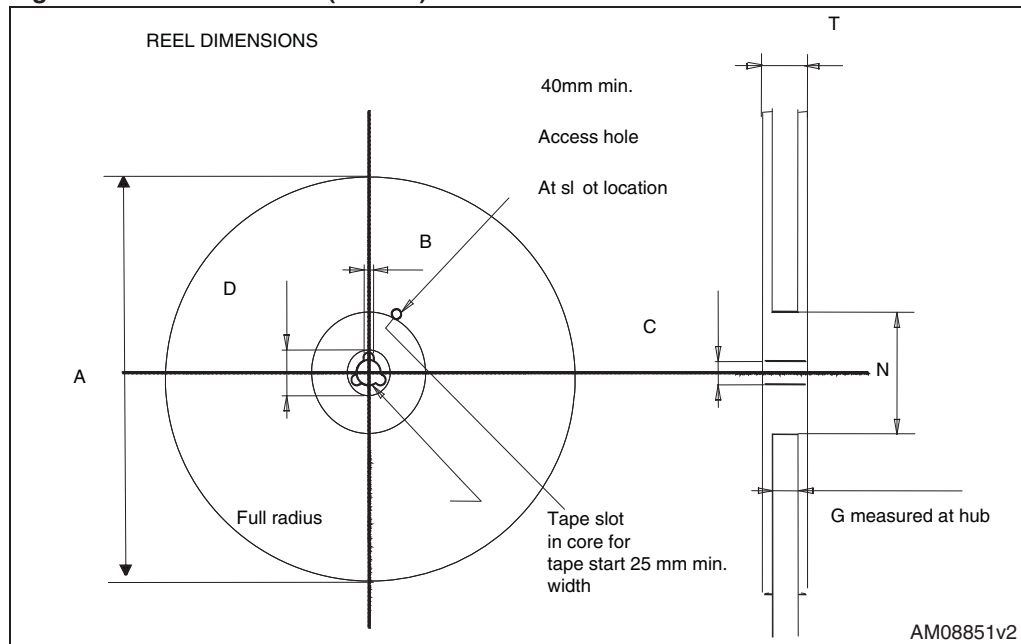

Figure 22. Reel for DPAK (TO-252)



## 6 Revision history

Table 11. Document revision history

Date	Revision	Changes
02-Oct-2009	1	First release.
18-May-2011	2	Document status promoted from preliminary data to datasheet.

**Please Read Carefully:**

Information in this document is provided solely in connection with ST products. STMicroelectronics NV and its subsidiaries ("ST") reserve the right to make changes, corrections, modifications or improvements, to this document, and the products and services described herein at any time, without notice.

All ST products are sold pursuant to ST's terms and conditions of sale.

Purchasers are solely responsible for the choice, selection and use of the ST products and services described herein, and ST assumes no liability whatsoever relating to the choice, selection or use of the ST products and services described herein.

No license, express or implied, by estoppel or otherwise, to any intellectual property rights is granted under this document. If any part of this document refers to any third party products or services it shall not be deemed a license grant by ST for the use of such third party products or services, or any intellectual property contained therein or considered as a warranty covering the use in any manner whatsoever of such third party products or services or any intellectual property contained therein.

**UNLESS OTHERWISE SET FORTH IN ST'S TERMS AND CONDITIONS OF SALE ST DISCLAIMS ANY EXPRESS OR IMPLIED WARRANTY WITH RESPECT TO THE USE AND/OR SALE OF ST PRODUCTS INCLUDING WITHOUT LIMITATION IMPLIED WARRANTIES OF MERCHANTABILITY, FITNESS FOR A PARTICULAR PURPOSE (AND THEIR EQUIVALENTS UNDER THE LAWS OF ANY JURISDICTION), OR INFRINGEMENT OF ANY PATENT, COPYRIGHT OR OTHER INTELLECTUAL PROPERTY RIGHT.**

**UNLESS EXPRESSLY APPROVED IN WRITING BY AN AUTHORIZED ST REPRESENTATIVE, ST PRODUCTS ARE NOT RECOMMENDED, AUTHORIZED OR WARRANTED FOR USE IN MILITARY, AIR CRAFT, SPACE, LIFE SAVING, OR LIFE SUSTAINING APPLICATIONS, NOR IN PRODUCTS OR SYSTEMS WHERE FAILURE OR MALFUNCTION MAY RESULT IN PERSONAL INJURY, DEATH, OR SEVERE PROPERTY OR ENVIRONMENTAL DAMAGE. ST PRODUCTS WHICH ARE NOT SPECIFIED AS "AUTOMOTIVE GRADE" MAY ONLY BE USED IN AUTOMOTIVE APPLICATIONS AT USER'S OWN RISK.**

Resale of ST products with provisions different from the statements and/or technical features set forth in this document shall immediately void any warranty granted by ST for the ST product or service described herein and shall not create or extend in any manner whatsoever, any liability of ST.

ST and the ST logo are trademarks or registered trademarks of ST in various countries.

Information in this document supersedes and replaces all information previously supplied.

The ST logo is a registered trademark of STMicroelectronics. All other names are the property of their respective owners.

© 2011 STMicroelectronics - All rights reserved

STMicroelectronics group of companies

Australia - Belgium - Brazil - Canada - China - Czech Republic - Finland - France - Germany - Hong Kong - India - Israel - Italy - Japan - Malaysia - Malta - Morocco - Philippines - Singapore - Spain - Sweden - Switzerland - United Kingdom - United States of America

[www.st.com](http://www.st.com)