

THIS DRAWING AND THE SUBJECT MATTER SHOWN THEREON ARE CONFIDENTIAL AND THE PROPERTY OF BEL/STEWART/TRP CONNECTOR AND SHALL NOT BE REPRODUCED, COPIED, OR USED IN ANY MANNER WITHOUT THE WRITTEN CONSENT OF TRP CONNECTOR.

PRODUCT MAY BE PROTECTED BY ONE OR MORE OF THE FOLLOWING US PATENTS:
 5736910 5939955 6425781 6428361 6554638 6840817 7123117
 7429195 7717749 7808751 6217391 6149050 7924130

REVISIONS					
P	LYR	DESCRIPTION	DATE	DWN	APVD
1		INITIAL RELEASE	16AUG2017	RL	TY

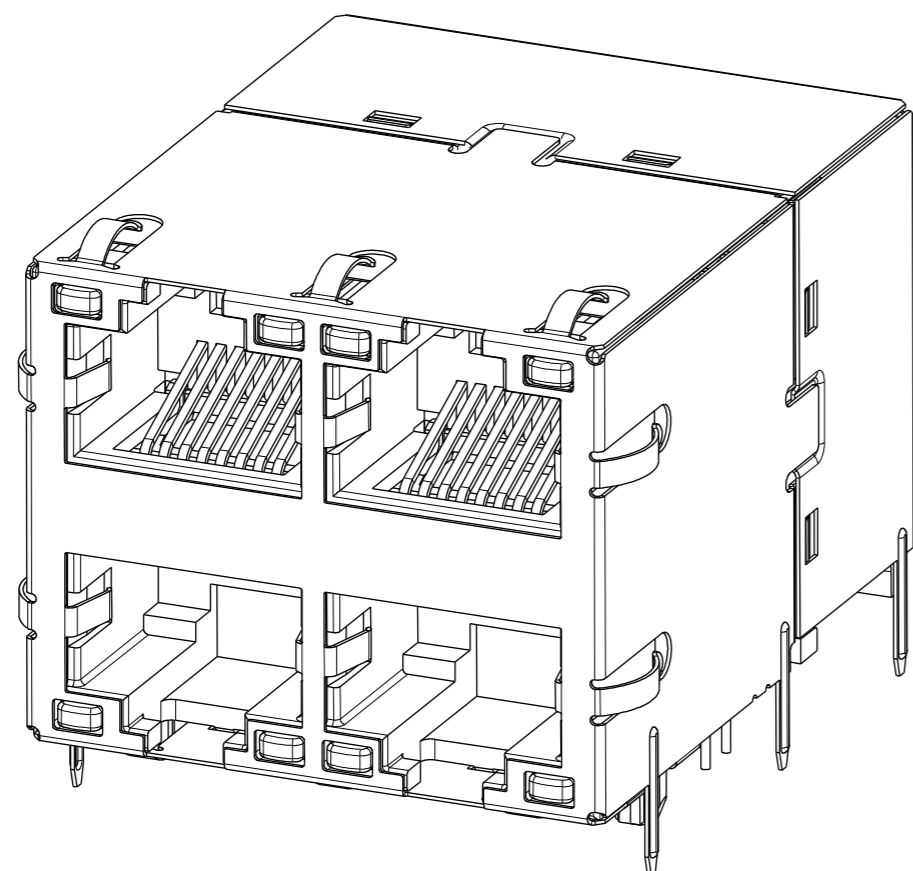

S9UFG02ET 5G 4PPOE CIRCUIT

TOP AND BOTTOM PORTS

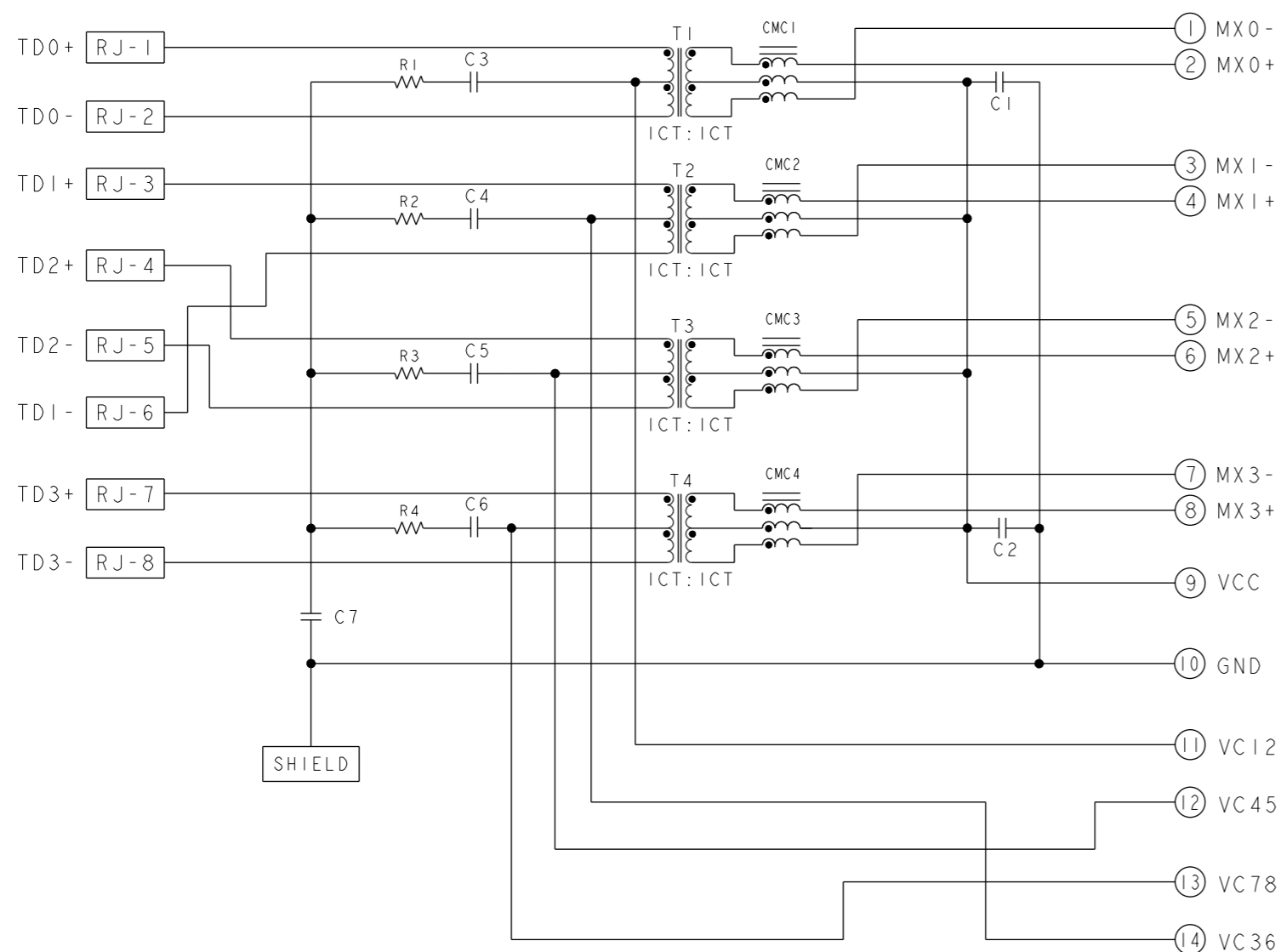

C1-C2 = 10nF, 50V, X7R, CAPACITORS
 C3-C6 = 22nF, 100V, CAPACITORS
 C7 = 1000pF, 2kV, CAPACITOR
 R1-R4 = 75 Ohms, 1/16W, RESISTORS

1. MATERIALS:
 PLASTIC HOUSING: BLACK, THERMOPLASTIC FLAMMABILITY RATING UL 94V-0
 SHIELD: BRASS, PREPLATED WITH 0.76um MIN SEMI-BRIGHT NICKEL,
 POST DIPPED WITH 2.54um MIN SAC SOLDER OR PURE TIN SOLDER DIP
 ON SOLDER TAILS,
 CONTACTS: PHOSPHOR BRONZE, 1.27um MIN OVERALL NICKEL
 UNDERPLATE WITH SELECT 1.27um MIN GOLD AT MATING INTERFACE AND
 2.54um MIN MATTE TIN ON SOLDER TAILS.
 LED: DIFFUSED EPOXY LENS, CARBON STEEL LEAD FRAME TAILS OF LED
 ARE PREPLATED WITH 2.03um MIN SILVER OVER 1.02um MIN NICKEL
 UNDERPLATE OVER 1.02um MIN COPPER UNDERPLATE. POST-PLATED WITH
 2.54um MIN MATTE TIN AND/OR SAC SOLDER DIP OR PURE TIN SOLDER DIP
2. MAGNETICS
 APPLICATION: 5G BASE-T, 4PPOE
 IMPEDANCE: 100 OHMS
 TURNS RATIO (CHIP:CABLE): 1:1 ALL FOUR PAIRS
 OPEN CIRCUIT INDUCTANCE (OCL):
 ALL CHANNELS 180uH MIN @ 100KHz, 0.1 VRMS WITH 8mA DC BIAS FROM -40°C TO 85°C,
 120uH MIN @ 100KHz, 0.1 VRMS WITH 23mA DC BIAS FROM -40°C TO 85°C
 ALL FOUR PAIRS BI-DIRECTIONAL
 POE CURRENT: 1A DC MAX
 PERFORMANCE @ 25°C, PLEASE REFER TO SEPARATE SHEET.
 ISOLATION VOLTAGE: 2250VDC(MAX) FOR 60 SECONDS WITH A RISE TIME OF
 500V/SEC AND WITH ALL PORTS CONNECTED.
3. PART NUMBER, DATE CODE AND COUNTRY OF ORIGIN ARE
 LOCATED IN APPROXIMATE AREA SHOWN.
 DATE CODE: YYWWD WHERE "YY" IS YEAR, "WW" IS WORK WEEK, "D" IS DAY
 OF WEEK, WITH SUNDAY = 1
4. TRP CONNECTOR LOGO AND AGENCY APPROVAL LOGO ARE
 LOCATED IN APPROXIMATE AREA SHOWN.
5. OPERATING TEMP: FROM -40°C TO 85°C.
6. RJ45 CAVITY CONFORMS TO FCC RULES AND REGULATION PART 68 SUBPART F.
7. INDICATED MAGNETIC CONNECTIONS ARE SYMMETRICAL AND
 SUPPORT AUTO-MDI/MDIX.
8. DATUM AND BASIC DIMENSION ESTABLISHED BY CUSTOMER.
9. BASIC DIMENSION ESTABLISHED BY CUSTOMER, BUT MAY NOT BE
 GREATER THAN 5.08mm.
10. LEDs ARE DRIVEN WITH CONSTANT CURRENT AT APPROX 20mA
 LED COLOR: DOMINANT WAVELENGTH (λD): GREEN 568 nm TYP. @ IF=20mA
 FORWARD VOLTAGE (VF): GREEN 2.2V TYP. @ IF=20mA
 DOMINANT WAVELENGTH (λD): ORANGE 605 nm TYP. @ IF=20mA
 FORWARD VOLTAGE (VF): ORANGE 2.1V TYP. @ IF=20mA
11. THE PARTS ARE RECOMMENDED FOR WAVE SOLDERING PROCESS,
 PEAK TEMPERATURE 260°C MAX, 10 SECONDS MAX.

2.30	GREEN/ORANGE	GREEN/ORANGE	GREEN/ORANGE	GREEN/ORANGE	2250539-1
DIM A	BOTTOM LED 2	BOTTOM LED 1	TOP LED 2	TOP LED 1	PART NUMBER
THIS DRAWING IS A CONTROLLED DOCUMENT, AND COMPLIANT TO ASME Y14.5M		DWN: RICK LI 16AUG2017 CHK: TOMMY REN / TERRY LIN 16AUG2017 APVD: TONY YUAN 16AUG2017		 DONGGUAN CHINA	
DIMENSIONS: mm		TOLERANCES UNLESS OTHERWISE SPECIFIED:		DESC: 2X2 S9UFG02ET 5G 4PPOE 100W CIRCUIT, W/ LED	
0 PLC ±0.25 1 PLC ±0.25 2 PLC ±0.25 3 PLC ± 4 PLC ± ANGLES ± APPLICATION SPEC		MODEL NAME: MAGJACK STACK 4PPOE		SIZE: A1	
PRODUCT SPEC: 108-104017		APPLICATION SPEC: -		SCALE: NTS	
CUSTOMER DRAWING		DRAWING NO: C=2250539		SHEET 1 OF 5	

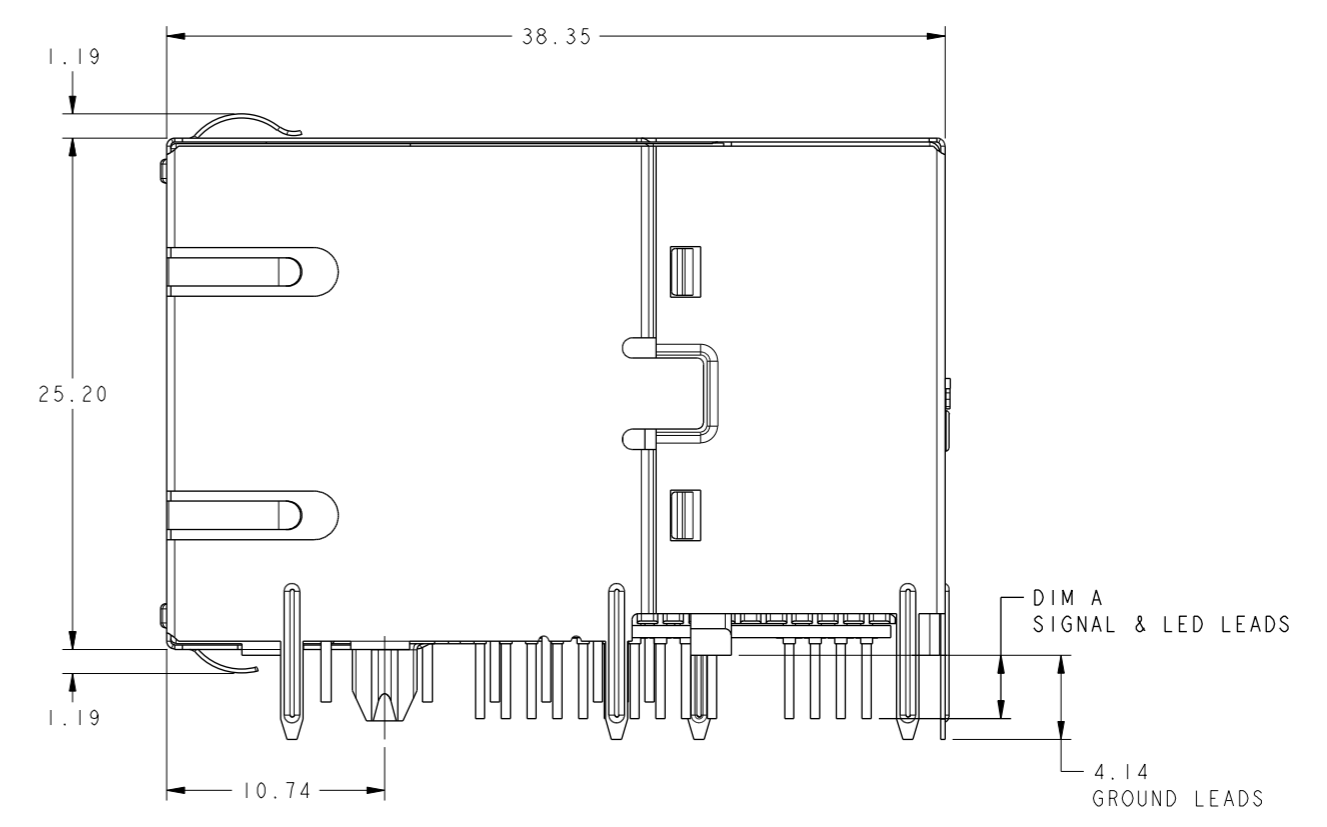
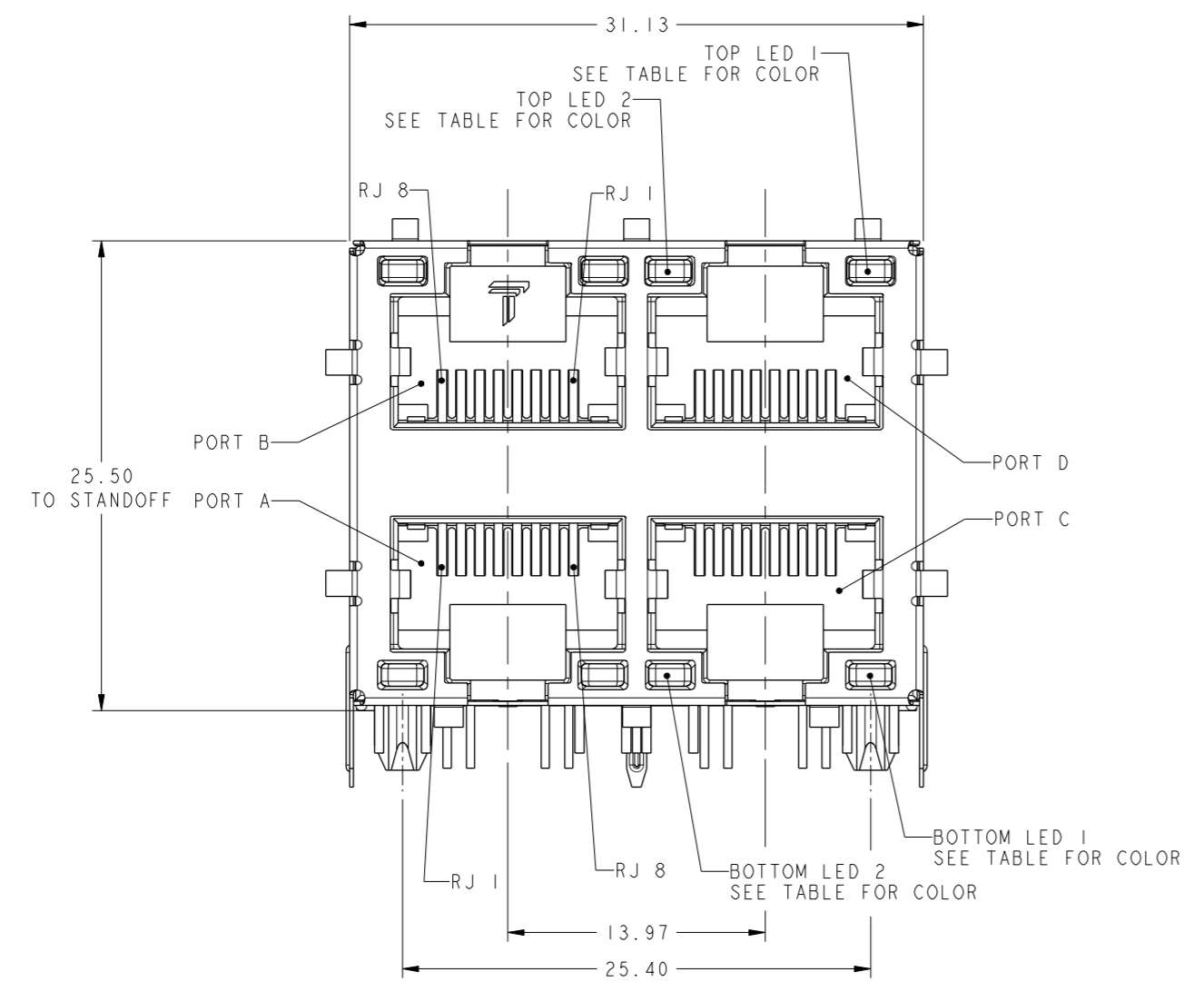
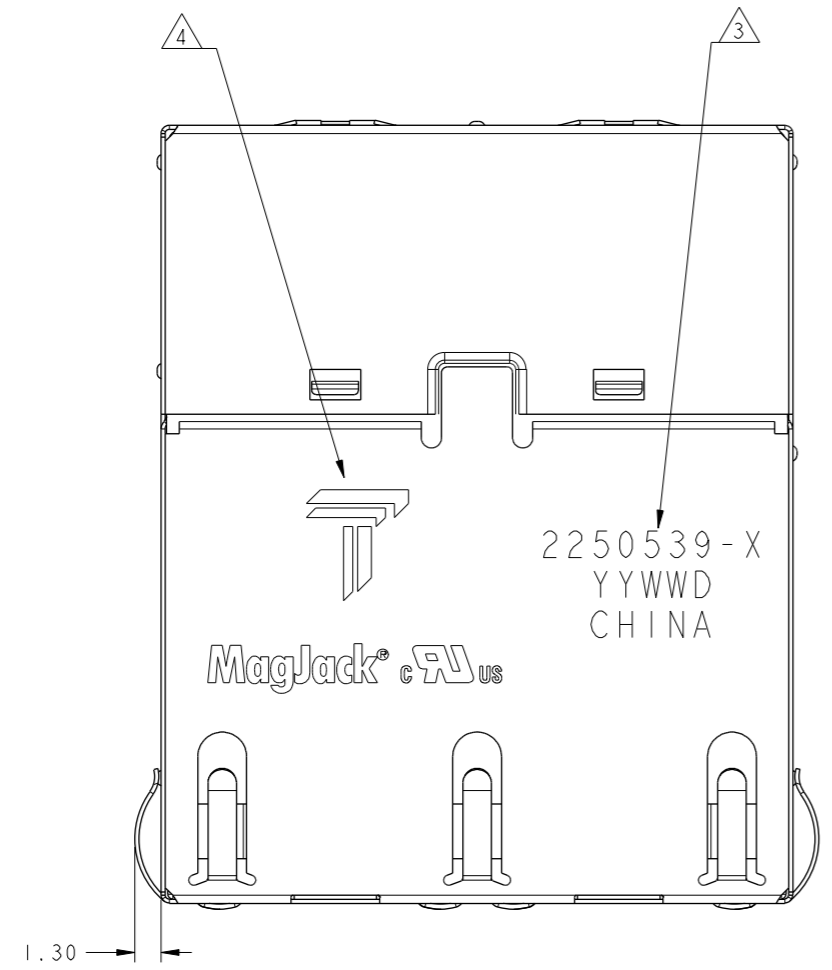

THIS DRAWING IS A CONTROLLED DOCUMENT. AND COMPLIANT TO ASME Y14.5M		DWN: RICK LI 16AUG2017 CHK: TOMMY REN / TERRY LIN 16AUG2017 APPR: TONY YUAN 16AUG2017	DONGGUAN CHINA
DIMENSIONS: mm	TOLERANCES UNLESS OTHERWISE SPECIFIED: 0 PLC ±0.25 1 PLC ±0.25 2 PLC ±0.25 3 PLC ± 4 PLC ± ANGLES ± APPLICATION SPEC -	MODEL NAME: MAGJACK STACK 4PPOE	
PRODUCT SPEC 108-104017		SIZE: A1 CAGE CODE: C=2250539 DRAWING NO:	RESTRICTED TO:
CUSTOMER DRAWING		SCALE: NTS	SHEET 2 OF 5 REV 1

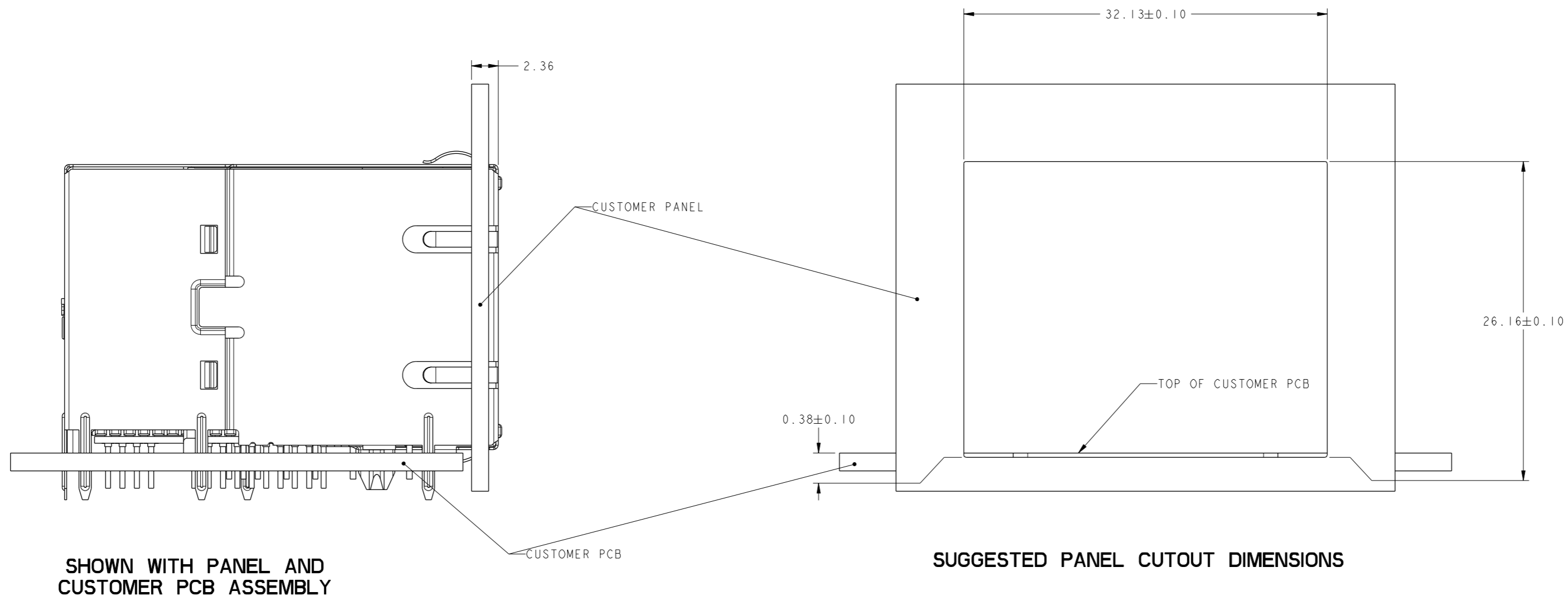

THIS DRAWING IS A CONTROLLED DOCUMENT. AND COMPLIANT TO ASME Y14.5M		DWN: RICK LI 16AUG2017 CHK: TOMMY REN / TERRY LIN 16AUG2017 APPR: TONY YUAN 16AUG2017	trp CONNECTOR a bel group DONGGUAN CHINA
DIMENSIONS: mm	TOLERANCES UNLESS OTHERWISE SPECIFIED: 0 PLC ±0.25 1 PLC ±0.25 2 PLC ±0.25 3 PLC ± 4 PLC ± ANGLES ± APPLICATION SPEC -	MODEL NAME MAGJACK STACK 4PPOE	
PRODUCT SPEC 108-104017		SIZE A1	CAGE CODE C=2250539
CUSTOMER DRAWING		SCALE NTS	SHEET 4 OF 5 REV 1

2250539					STOCK DISPOSITION			
2X2 S9UFG02ET 5G 4PPOE 100W CIRCUIT, W/ LED					A: CONTINUE AS IS		D: USE OLD FIRST	
					B: REWORK		E: PARTS TO CONFORM	
REVISION HISTORY					C: SCRAP		F: OTHER	
DATE	REV	CHANGES	REASON	APPROVAL	INVENTORY (A,B,C,D,E,F)	WORK IN PROCESS (A,B,C,F)	SUPPLIER ORDERS (A,E,F)	OPEN CUST ORDERS (A,E,F)
16AUG2017	I	-	INITIAL RELEASE	TY	-	-	-	-

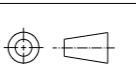
THIS DRAWING IS A CONTROLLED DOCUMENT. AND COMPLIANT TO ASME Y14.5M		DWN: RICK LI 16AUG2017		 trp CONNECTOR <small>a bel group</small>		DONGGUAN CHINA	
DIMENSIONS: mm		TOLERANCES UNLESS OTHERWISE SPECIFIED:				CHK: TOMMY REN / TERRY LIN 16AUG2017	
		0 PLC ±0.25 1 PLC ±0.25 2 PLC ±0.25 3 PLC ± 4 PLC ± ANGLES ± APPLICATION SPEC -		MODEL NAME: MAGJACK STACK 4PPOE		DESC: 2X2 S9UFG02ET 5G 4PPOE 100W CIRCUIT, W/ LED	
PRODUCT SPEC: 108-104017		APPLICATION SPEC: -		SIZE: A1		CAGE CODE: C=2250539	
CUSTOMER DRAWING				SCALE: NTS		SHEET 5 OF 5 REV 1	