

**SINGLE-PHASE GLASS PASSIVATED
SILICON BRIDGE RECTIFIER**
VOLTAGE RANGE 50 to 1000 Volts CURRENT 2.0 Amperes

FEATURES

- * Good for automation insertion
- * Surge overload rating - 60 amperes peak
- * Ideal for printed circuit board
- * Reliable low cost construction utilizing molded
- * Glass passivated device
- * Polarity symbols molded on body
- * Mounting position: Any

MECHANICAL DATA

- * Epoxy: Device has UL flammability classification 94V-0

MAXIMUM RATINGS AND ELECTRICAL CHARACTERISTICS

Ratings at 25 °C ambient temperature unless otherwise specified.
resistive or inductive load.



DB-S

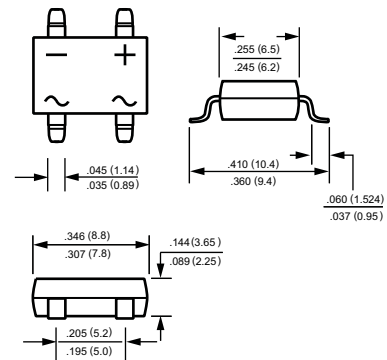

MAXIMUM RATINGS (At $T_A = 25^\circ\text{C}$ unless otherwise noted)

| RATINGS | SYMBOL | DB201S | DB202S | DB203S | DB204S | DB205S | DB206S | DB207S | UNITS |
|---|-----------------|--------------|--------|--------|--------|--------|--------|--------|---------------------------|
| Maximum Recurrent Peak Reverse Voltage | V_{RRM} | 50 | 100 | 200 | 400 | 600 | 800 | 1000 | Volts |
| Maximum RMS Bridge Input Voltage | V_{RMS} | 35 | 70 | 140 | 280 | 420 | 560 | 700 | Volts |
| Maximum DC Blocking Voltage | V_{DC} | 50 | 100 | 200 | 400 | 600 | 800 | 1000 | Volts |
| Maximum Average Forward Output Current at $T_A = 40^\circ\text{C}$ | I_O | 2.0 | | | | | | | Amps |
| Peak Forward Surge Current 8.3 ms single half sine-wave superimposed on rated load (JEDEC method) | I_{FSM} | 60 | | | | | | | Amps |
| Typical Current Squared Time | I^2T | 14.9 | | | | | | | A·S |
| Typical Thermal Resistance (Note 2) | $R_{\theta JA}$ | 40 | | | | | | | $^\circ\text{C}/\text{W}$ |
| | $R_{\theta JL}$ | 15 | | | | | | | |
| Operating and Storage Temperature Range | T_J, T_{STG} | -55 to + 150 | | | | | | | $^\circ\text{C}$ |

ELECTRICAL CHARACTERISTICS (At $T_A = 25^\circ\text{C}$ unless otherwise noted)

| CHARACTERISTICS | SYMBOL | DB201S | DB202S | DB203S | DB204S | DB205S | DB206S | DB207S | UNITS |
|--|-----------------------------|--------|--------|--------|--------|--------|--------|--------|-------|
| Maximum Forward Voltage Drop per Bridge Element at 2.0A DC | V_F | 1.1 | | | | | | | Volts |
| Maximum Reverse Current at Rated DC Blocking Voltage per element | @ $T_A = 25^\circ\text{C}$ | 5.0 | | | | | | | uAmps |
| | @ $T_A = 125^\circ\text{C}$ | 0.5 | | | | | | | |

Note: 1. "ROHS compliant"

2. Thermal Resistance: Mounted on PCB.

2022-09/97
REV:D

RATING AND CHARACTERISTICS CURVES (DB201S THRU DB207S)

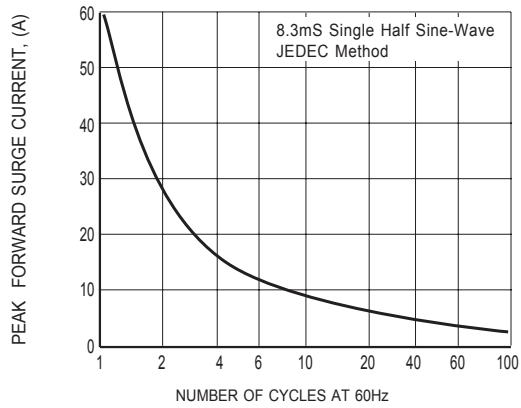

FIG. 1 - MAXIMUM NON-REPETITIVE FORWARD SURGE CURRENT

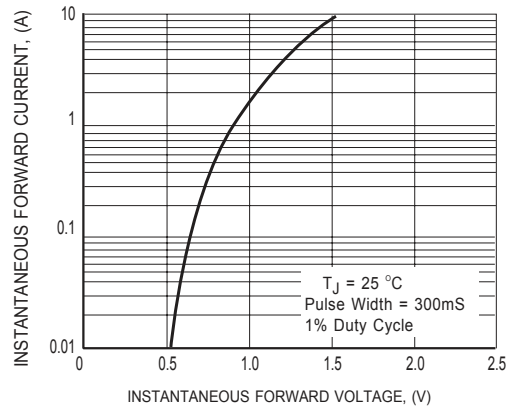

FIG. 2 TYPICAL INSTANTANEOUS FORWARD CHARACTERISTICS

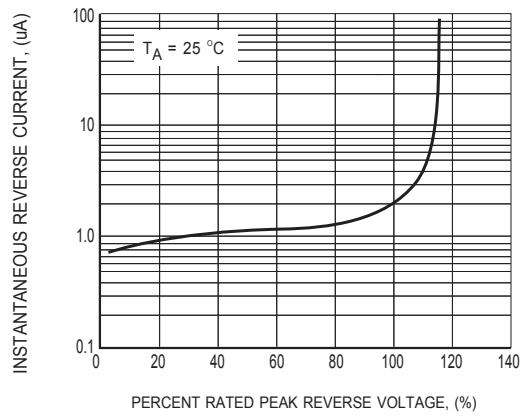

FIG. 3 TYPICAL REVERSE CHARACTERISTICS

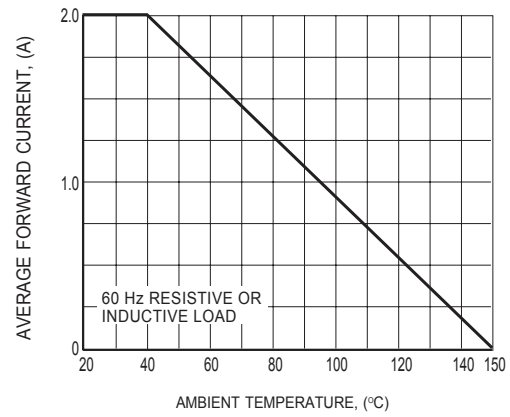
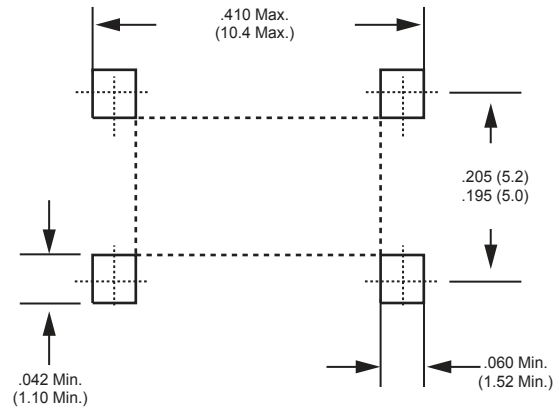

FIG. 4 TYPICAL FORWARD CURRENT DERATING CURVE

Mounting Pad Layout



Dimensions in inches and (millimeters)

REEL TAPING SPECIFICATIONS FOR SURFACE MOUNT DEVICES - DBS

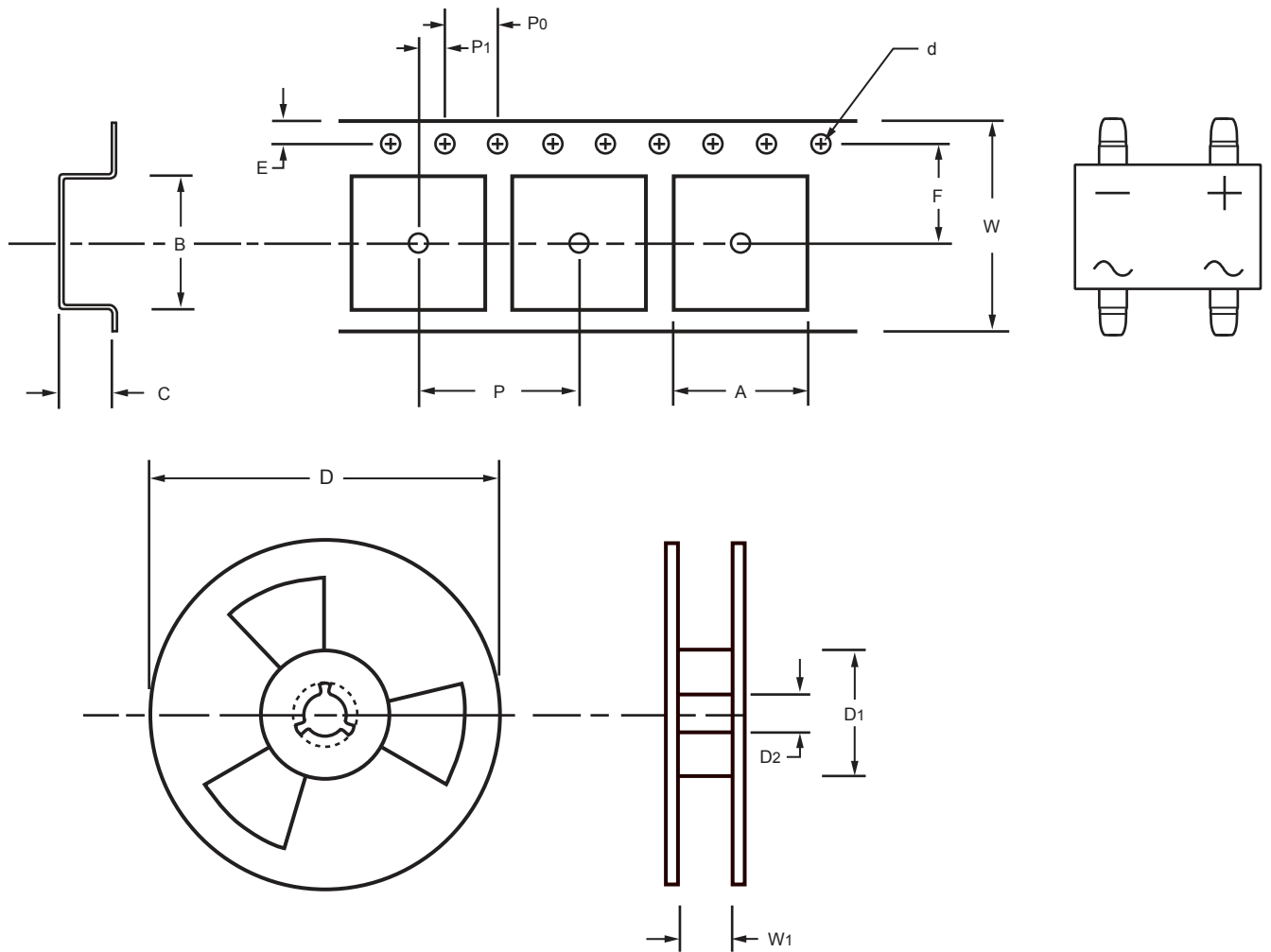

Fig.: Configuration of DBS REEL TAPING

| ITEM | SYMBOL | SPECIFICATIONS (mm) | SPECIFICATIONS (inch) |
|------------------------|--------|---------------------|-----------------------|
| Carrier width | A | 10.2 ± 0.1 | 0.402 ± 0.004 |
| Carrier length | B | 10.3 ± 0.1 | 0.406 ± 0.004 |
| Carrier depth | C | 4.25 ± 0.1 | 0.167 ± 0.004 |
| Sprocket hole | d | 1.55 ± 0.1 | 0.061 ± 0.004 |
| Reel outside diameter | D | 330.0 ± 2.0 | 12.992 ± 0.079 |
| Reel inner diameter | D1 | 16.4 ± 2.0 | 0.646 ± 0.079 |
| Feed hole diameter | D2 | 13.0 ± 0.2 | 0.512 ± 0.008 |
| Sprocket hole position | E | 1.75 ± 0.1 | 0.069 ± 0.004 |
| Punch hole position | F | 7.5 ± 0.1 | 0.295 ± 0.004 |
| Punch hole pitch | P | 12.0 ± 0.1 | 0.472 ± 0.004 |
| Sprocket hole pitch | P0 | 4.0 ± 0.1 | 0.157 ± 0.004 |
| Embossment center | P1 | 2.0 ± 0.1 | 0.079 ± 0.004 |
| Tape width | W | 16.0 ± 0.3 | 0.63 ± 0.012 |
| Reel width | W1 | 22.4 ± 1.0 | 0.882 ± 0.039 |

Notes : 1. Devices are packed in accordance with EIA stand RS-481-D and specifications listed above. Available only for DB-S devices.

2. Available on 7 inch (1000 c.t.) or 13 inch (5000 c.t.) diameter reels.

Visit [http:// www.rectron.com](http://www.rectron.com) for complete datasheets

Marking Description

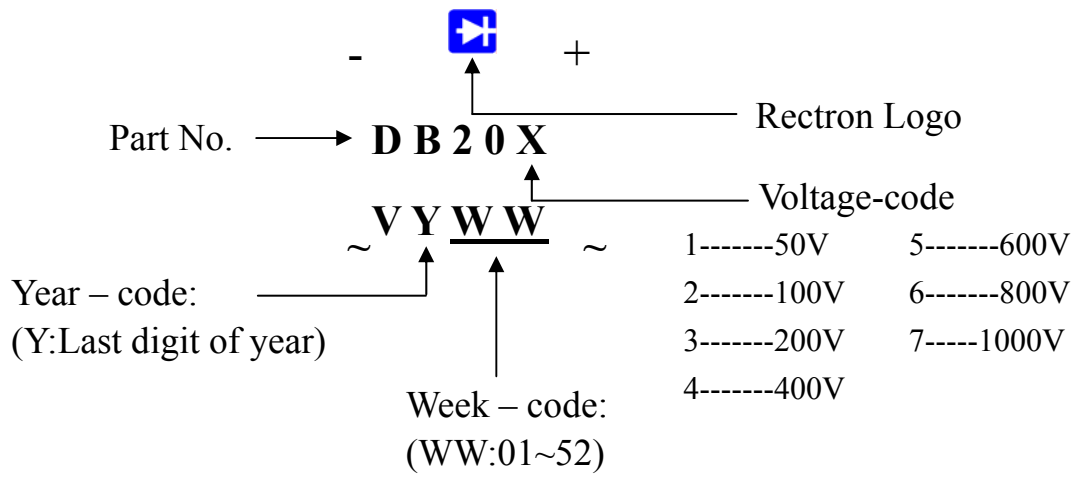

PACKAGING OF DIODE AND BRIDGE RECTIFIERS

REEL PACK

| PACKAGE | PACKING CODE | EA PER REEL | EA PER INNER BOX | COMPONENT SPACE (mm) | TAPE SPACE (mm) | REEL DIA (mm) | CARTON SIZE (mm) | EA PER CARTON | GROSS WEIGHT(Kg) |
|---------|--------------|-------------|------------------|----------------------|-----------------|---------------|------------------|---------------|------------------|
| DB-S | -T/W | 1,000 | 1,000 | 9.5 | 52 | 330 | 360*355*360 | 8,000 | 9.8 |

DISCLAIMER NOTICE

Rectron Inc reserves the right to make changes without notice to any product specification herein, to make corrections, modifications, enhancements or other changes. Rectron Inc or anyone on its behalf assumes no responsibility or liability for any errors or inaccuracies. Data sheet specifications and its information contained are intended to provide a product description only. "Typical" parameters which may be included on RECTRON data sheets and/ or specifications can and do vary in different applications and actual performance may vary over time. Rectron Inc does not assume any liability arising out of the application or use of any product or circuit.

Rectron products are not designed, intended or authorized for use in medical, life-saving implant or other applications intended for life-sustaining or other related applications where a failure or malfunction of component or circuitry may directly or indirectly cause injury or threaten a life without expressed written approval of Rectron Inc. Customers using or selling Rectron components for use in such applications do so at their own risk and shall agree to fully indemnify Rectron Inc and its subsidiaries harmless against all claims, damages and expenditures.

