

### Device Features

- +31.8 dBm Input IP3 @3.5G
- 9.0 dB Conversion Loss @3.5G
- Integrated LO Driver
- -2 to +2 dBm LO drive level
- Available 3.3 V to 5 V single voltage
- MSL 3, TDFN-8L 3x3, Green / RoHS2 compliant
- ESD HBM Class 1A

### Package Type



### Product Description

The BM351 is a high linearity and dynamic covering range from 2.5 GHz to 6.0 GHz on 3.3 V to 5 V with a passive GaAs FET converter and two stage LO driver. This is packaged in a plastic surface mountable TDFN-8Lead 3x3 with Lead-free / Green / RoHS2 compliant. Typical Input IP3 and Conversion loss are 32 dBm and 8.8dB, respectively. All devices are 100% RF/DC screened.

### Application Circuit

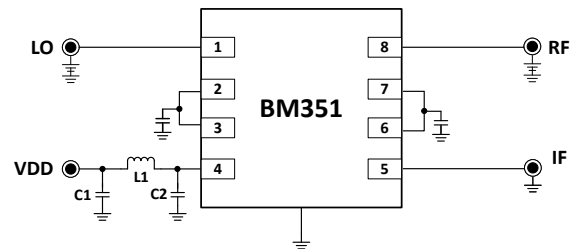

IF Frequency	BOM	Value
100~500 MHz	C1	N/C
	C2	1nF
	L1	27nH

### Applications

- Base station /Repeaters Infrastructure/Small Cell
- Commercial/Industrial/Military wireless system
- 5G/LTE / WCDMA /CDMA Wireless Infrastructure
- MMD & wireless LAN

### Functional Block Diagram

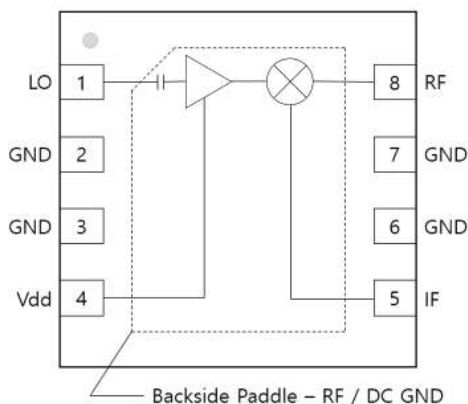

### Recommended Operating Conditions

Parameter	Min.	Typical	Max.	Unit
Bandwidth	2500		6000	MHz
$I_d$ @ (Vd = 5.0V)	75	85	95	mA
$I_d$ @ (Vd = 3.3V)	55	62	70	mA
$R_{TH}$		99		°C/W
Operating Case Temperature	-40		+85	°C

#### Typical Performance<sup>1</sup>

Test condition \_ Measured on BeRex E/B at 25°C, 50ohm system, Vdd=5V I<sub>ds</sub>=85mA

Parameter	Min	Typ	Max	Min	Typ	Max	Min	Typ	Max	Min	Typ	Max	Units
RF Frequency Range	2500~2700			3300~3700			4600~4800			5500~6000			MHz
LO Frequency Range	2300~2650			2800~3600			4100~4700			5000~5900			MHz
IF Frequency Range	50~200			50~700			50~700			50~700			MHz
SSB Conversion Loss		8.8			8.9			9.2			9.7		dB
Input IP <sub>3</sub> <sup>2</sup>		26.9			28.8			37.4			29.5		dBm
LO Leakage RF Port		-11.1			0.7			5.5			-1.3		dBm
LO Leakage IF Port		-20.9			-22.9			-15.0			-15.6		dBm
RF-IF Isolation		-31.2			-37.9			-31.5			-29.8		dB
RF Return Loss		-7.2			-22.0			-14.1			-13.4		dB
IF Return Loss		-7.6			-4.4			-5.6			-19.0		dB
Input P <sub>1dB</sub>		17.1			22.1			24.1			19.7		dBm
LO Drive Level	-2	0	2	-2	0	2	-2	0	2	-2	0	2	dBm

Test condition \_ Measured on BeRex E/B at 25°C, 50ohm system, Vdd=3.3V I<sub>ds</sub>= 62mA

Parameter	Min	Typ	Max	Min	Typ	Max	Min	Typ	Max	Min	Typ	Max	Units
RF Frequency Range	2500~2700			3300~3700			4600~4800			5500~6000			MHz
LO Frequency Range	2300~2650			2800~3600			4100~4700			5000~5900			MHz
IF Frequency Range	50~200			50~700			50~700			50~700			MHz
SSB Conversion Loss		8.5			8.5			8.7			11.2		dB
Input IP <sub>3</sub> <sup>2</sup>		27.9			25.6			36.1			24.1		dBm
LO Leakage RF Port		-15.1			-3.3			1.5			-7.3		dBm
LO Leakage IF Port		-22.9			-24.0			-17.2			-17.4		dBm
RF-IF Isolation		-31.2			-38.6			-32.1			-30.7		dB
RF Return Loss		-7.4			-20.2			-12.3			-12.1		dB
IF Return Loss		-5.7			-5.7			-6.7			-17.2		dB
Input P <sub>1dB</sub>		15.3			19.6			21.1			15.6		dBm
LO Drive Level	-2	0	2	-2	0	2	-2	0	2	-2	0	2	dBm

<sup>1</sup> Specifications show on 0dBm-LO driven power and 200 MHz-IF frequency in a down converting configuration with Low-side LO.

<sup>2</sup> IIP<sub>3</sub> is measured on two tone with RF in power 0dBm/ tone , F<sub>2</sub>-F<sub>1</sub> = 1 MHz.

#### Absolute Maximum Ratings

Parameter	Rating	Unit
Storage Temperature	-55 to +155	°C
Junction Temperature	195	°C
Supply Voltage	7	V
LO Power	10	dBm
Input RF/IF Power	25	dBm

Operation of this device above any of these parameters may result in permanent damage.

**Typical Test Data : 5V, RF to IF Converting**

Test condition : Measured on BeRex E/B at 25°C, 50ohm system, Vdd=5V, I<sub>ds</sub>=85mA , Down converting

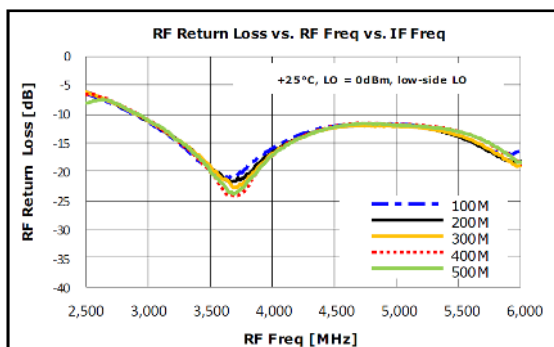
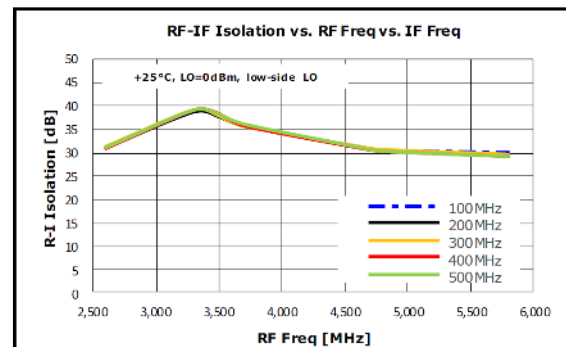
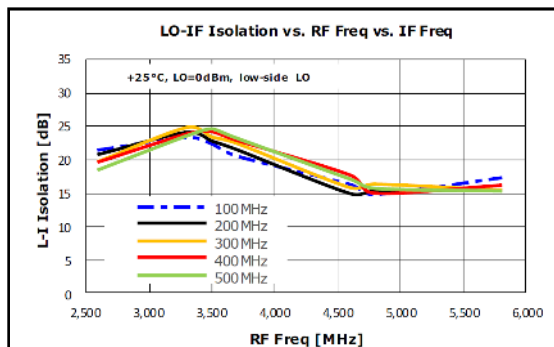
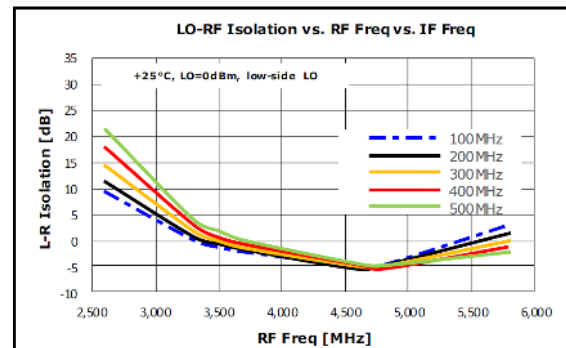
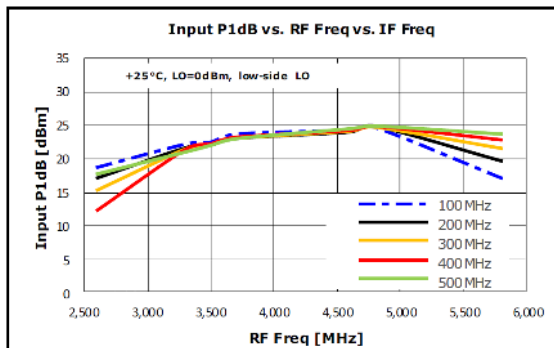
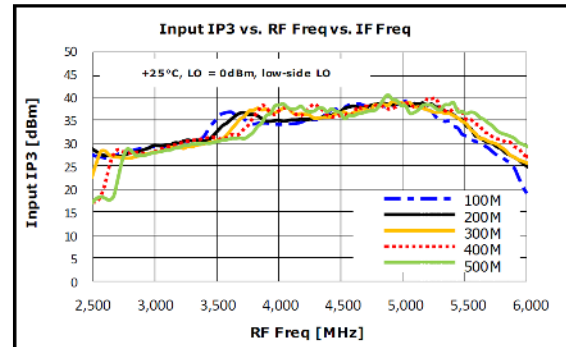
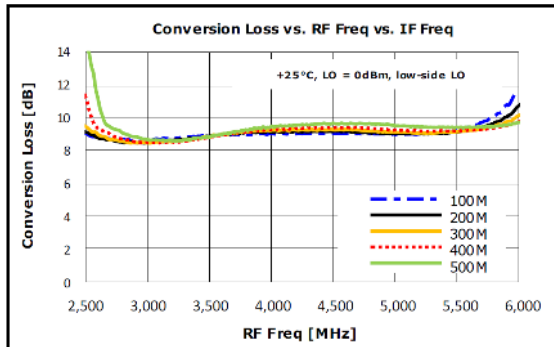

**Typical Test Data : 5V, RF to IF Converting**

Test condition : Measured on BeRex E/B at 25°C, 50ohm system, Vdd=5V, I<sub>ds</sub>=85mA , Down converting

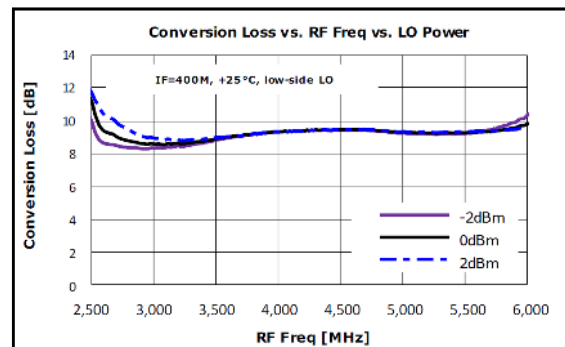
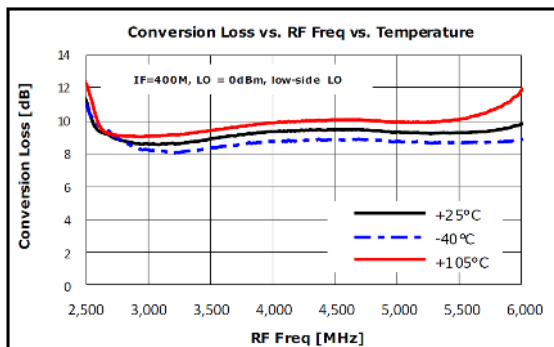
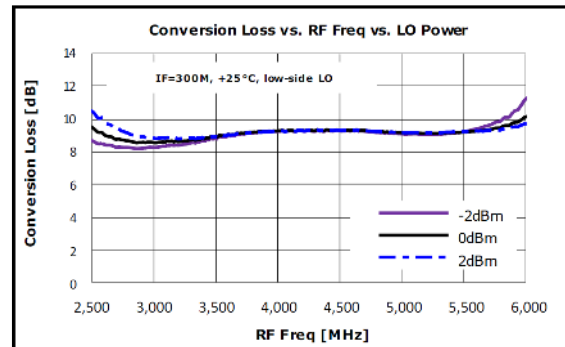
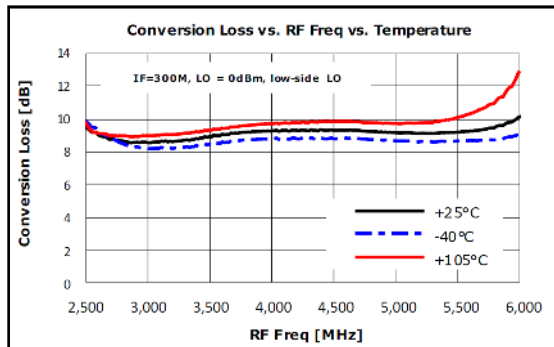
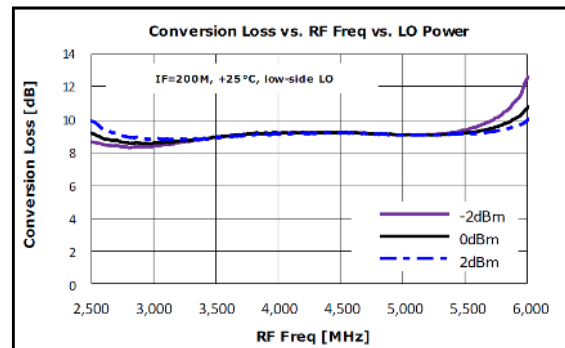
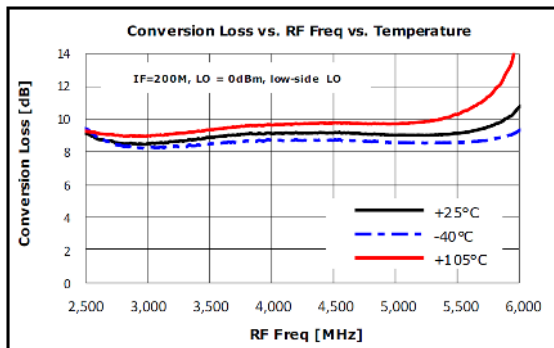
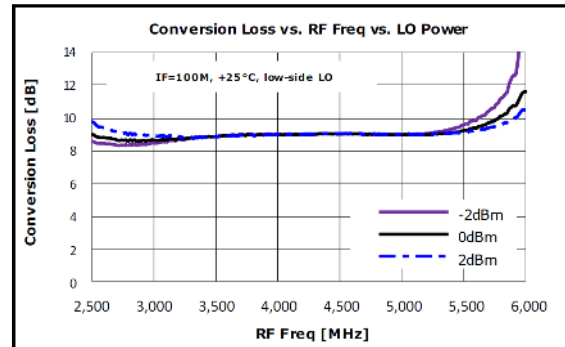
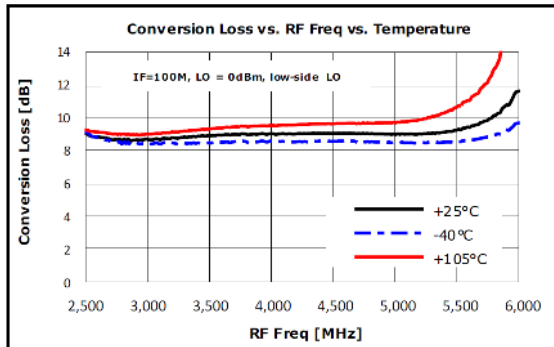

#### Typical Test Data : 5V, RF to IF Converting

Test condition : Measured on BeRex E/B at 25°C, 50ohm system, Vdd=5V, I<sub>ds</sub>=85mA , Down converting

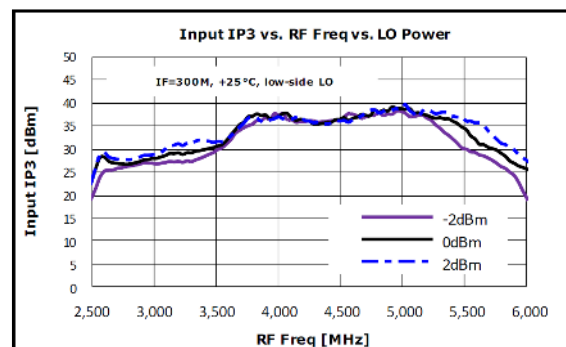
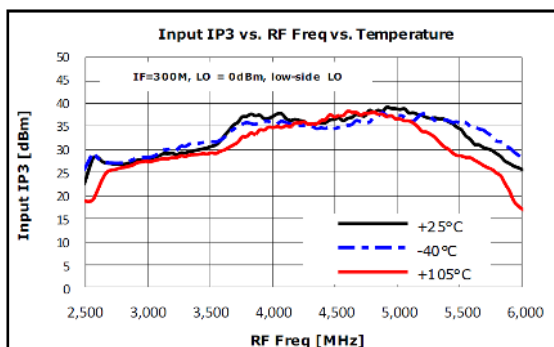
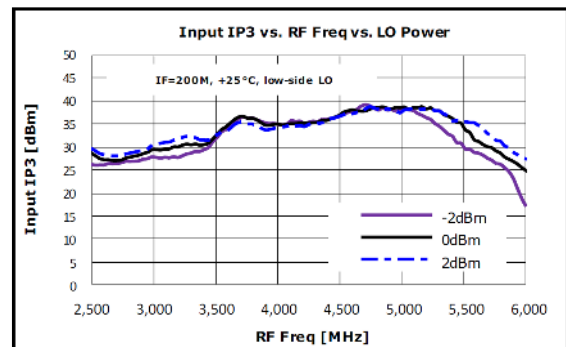
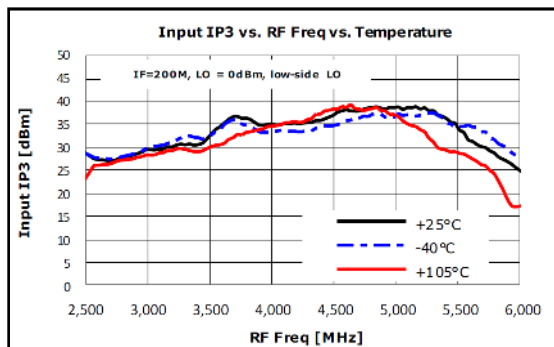
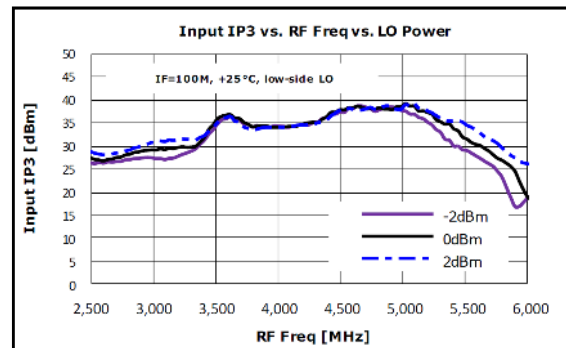
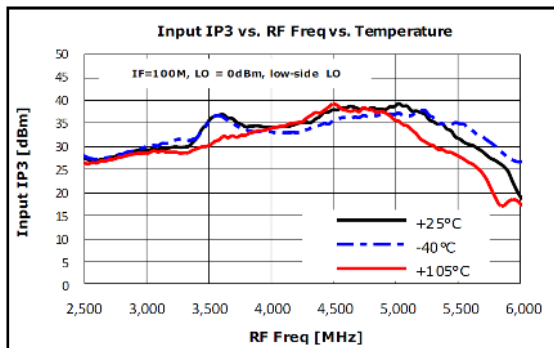
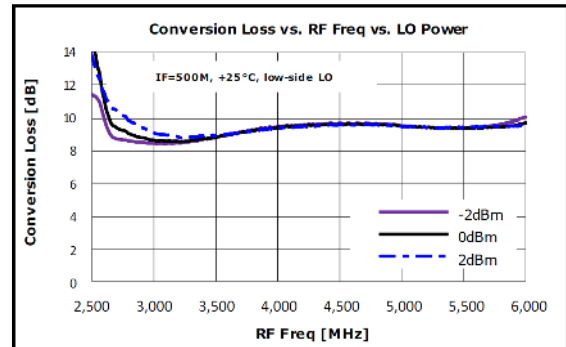
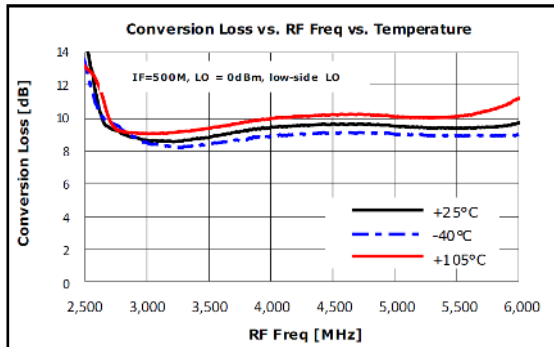

#### Typical Test Data : 5V, RF to IF Converting

Test condition : Measured on BeRex E/B at 25°C, 50ohm system, Vdd=5V, I<sub>ds</sub>=85mA , Down converting

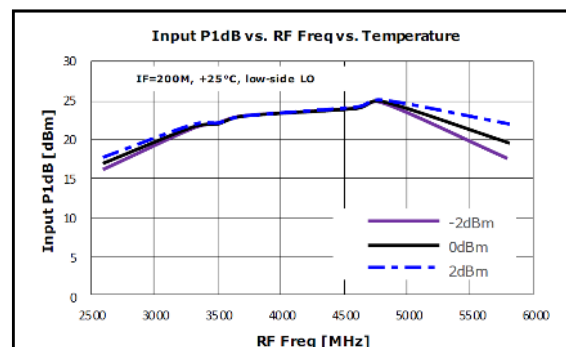
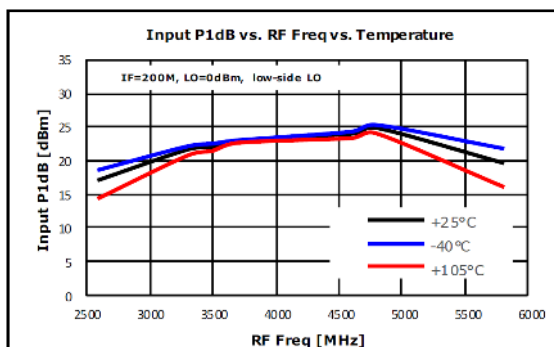
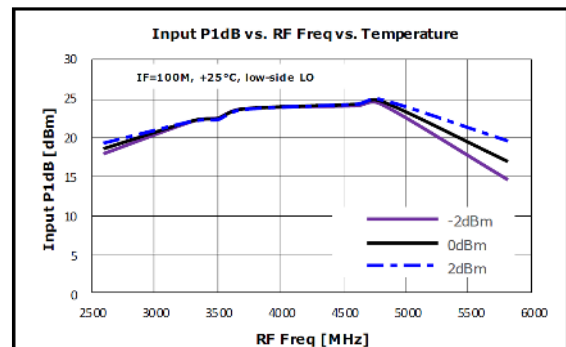
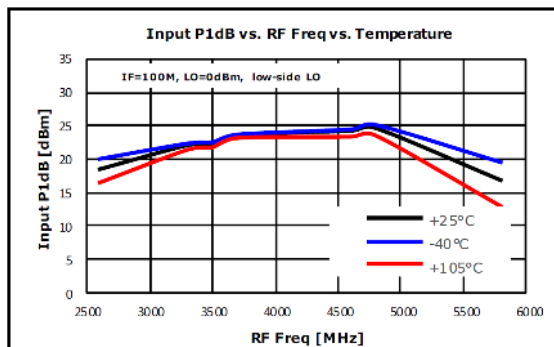
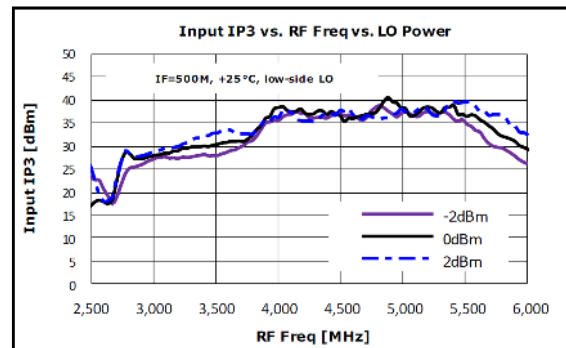
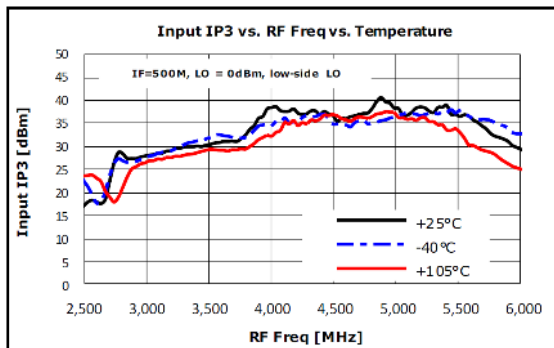
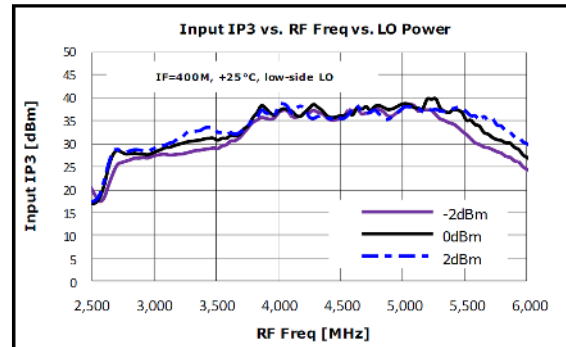
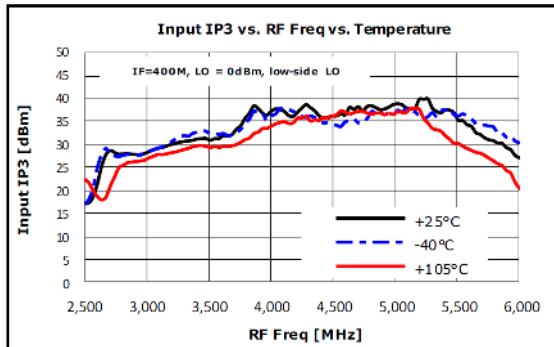

#### Typical Test Data : 5V, RF to IF Converting

Test condition : Measured on BeRex E/B at 25°C, 50ohm system, Vdd=5V, I<sub>ds</sub>=85mA , Down converting

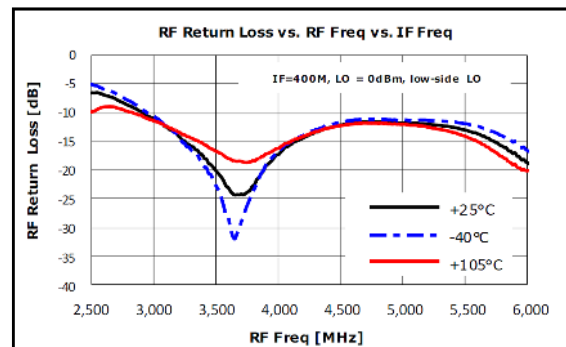
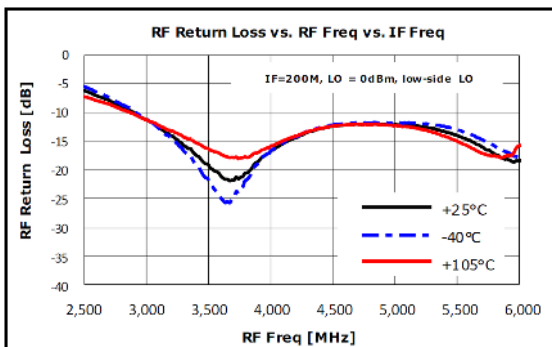
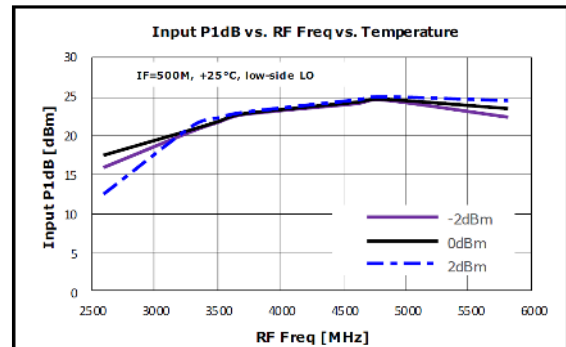
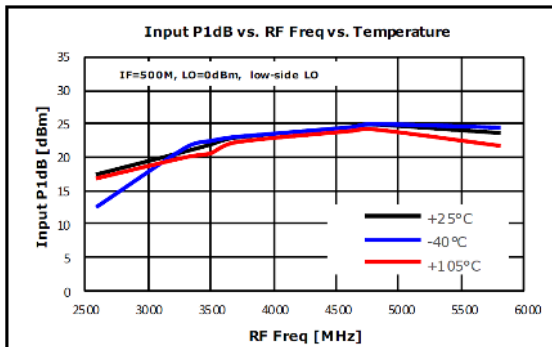
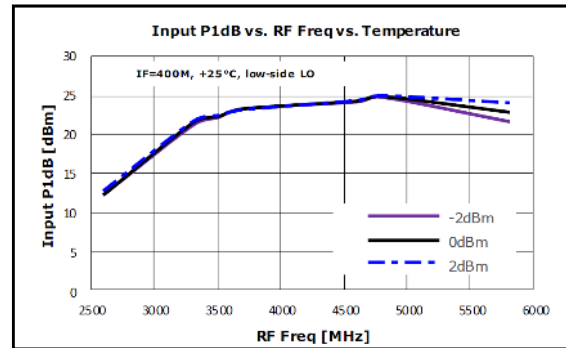
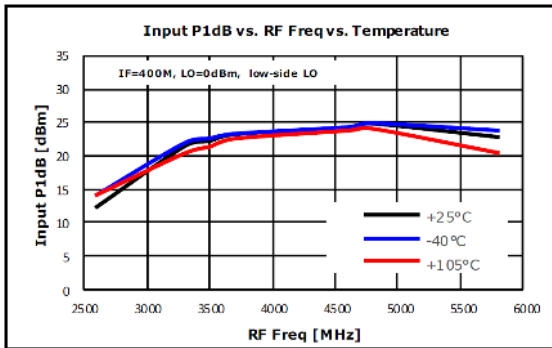
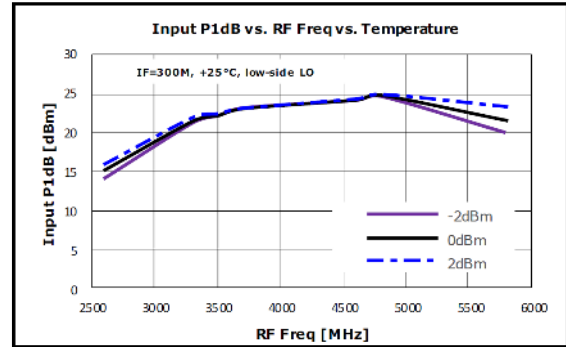
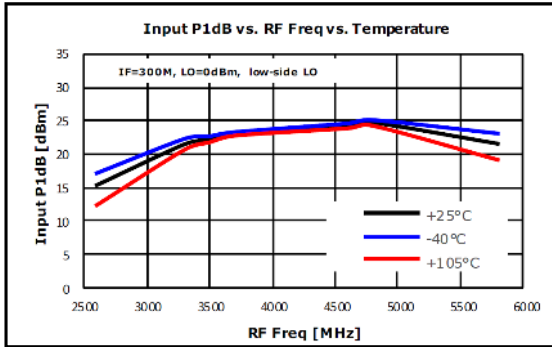

#### Typical Test Data : 5V, IF to RF Converting

Test condition : Measured on BeRex E/B at 25°C, 50ohm system, Vdd=5V, I<sub>ds</sub>=85mA , Up converting

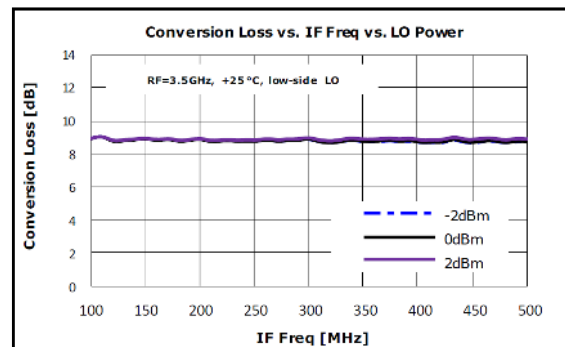
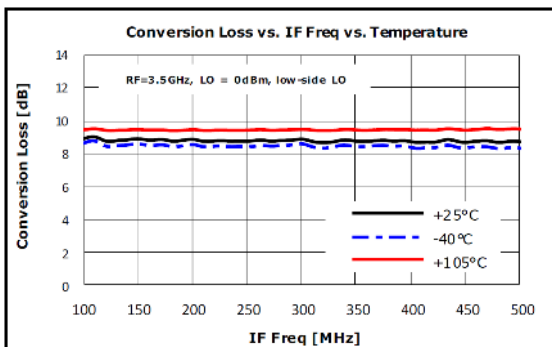
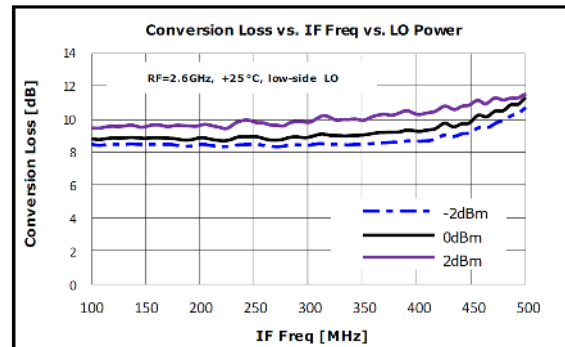
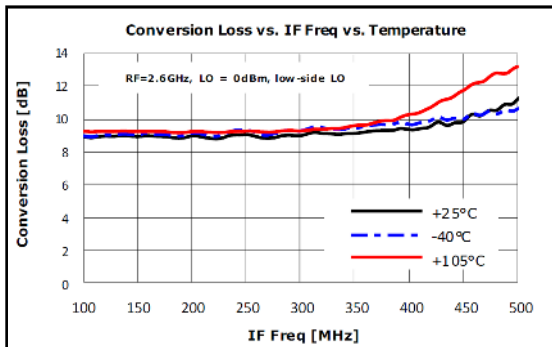
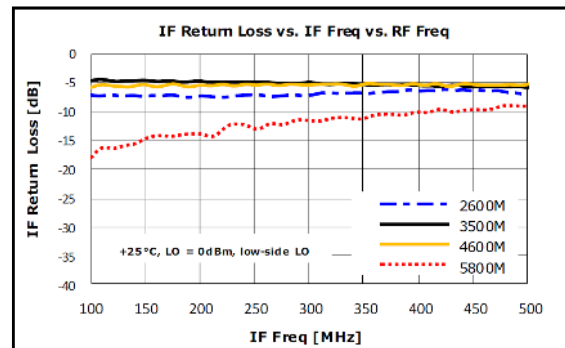
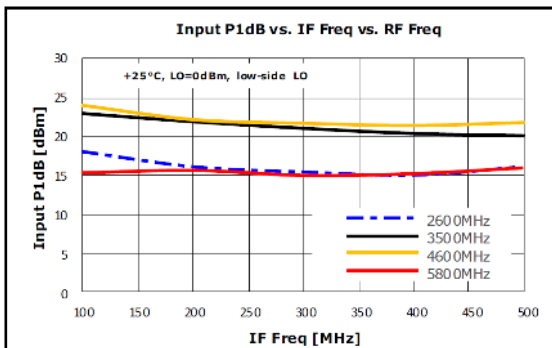
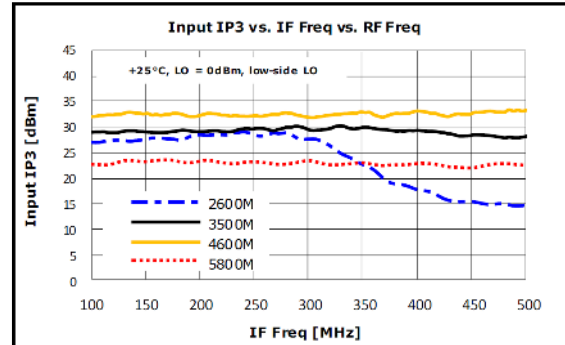
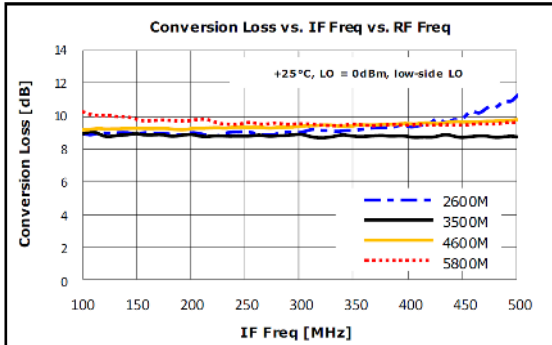



**Typical Test Data : 5V, IF to RF Converting**

Test condition : Measured on BeRex E/B at 25°C, 50ohm system, Vdd=5V, I<sub>ds</sub>=85mA , Up converting

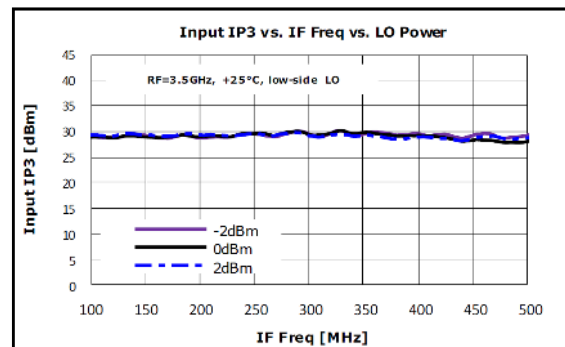
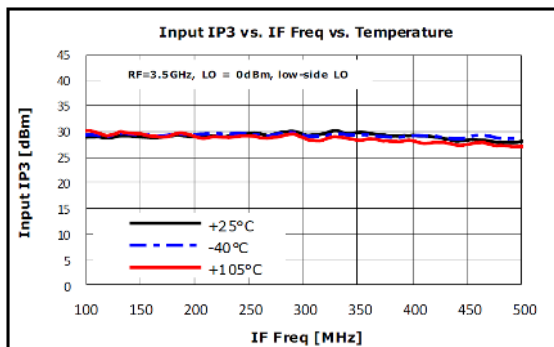
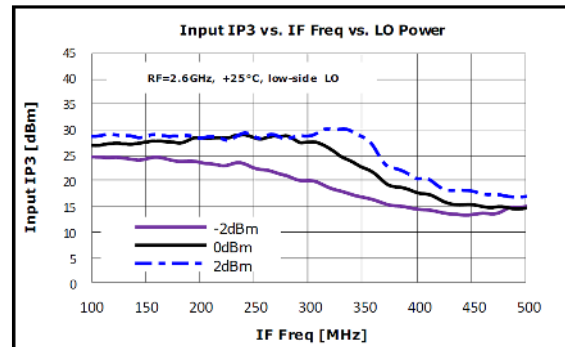
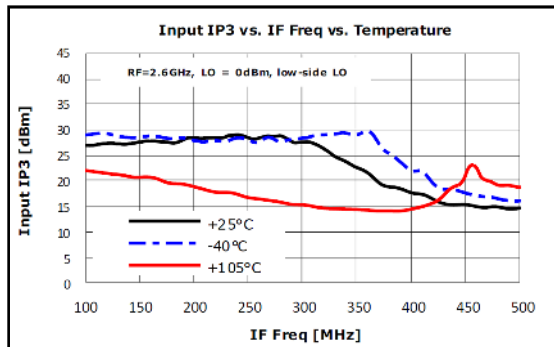
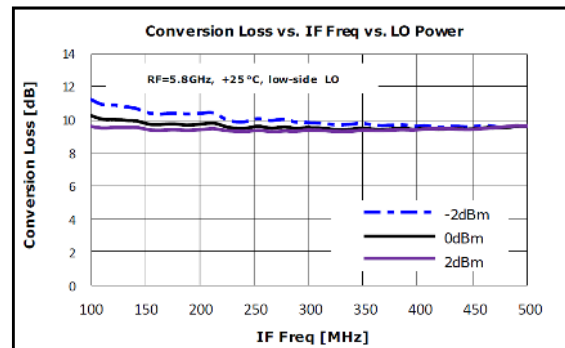
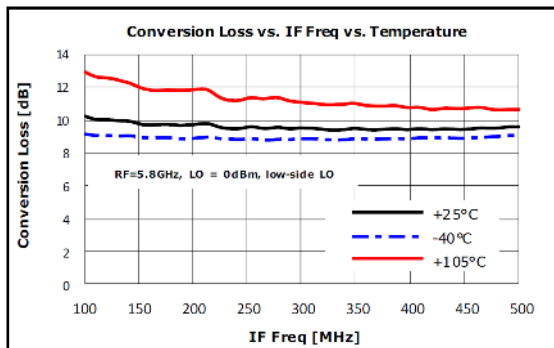
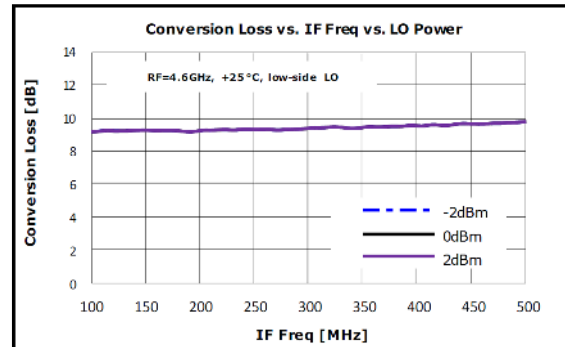
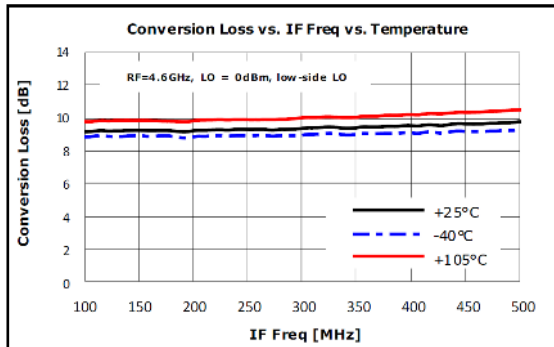

**Typical Test Data : 5V, IF to RF Converting**

Test condition : Measured on BeRex E/B at 25°C, 50ohm system, Vdd=5V, I<sub>ds</sub>=85mA , Up converting

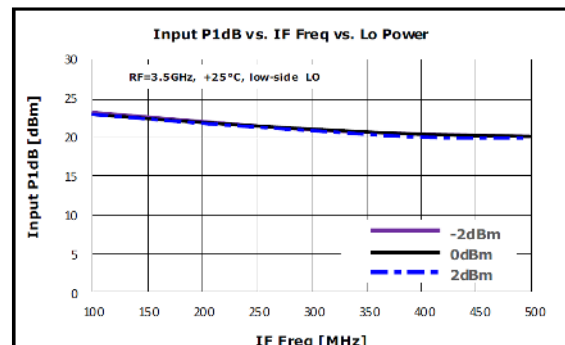
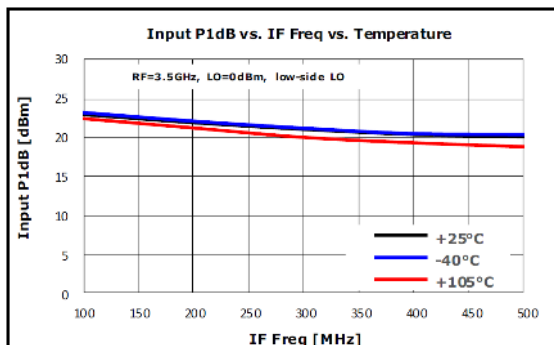
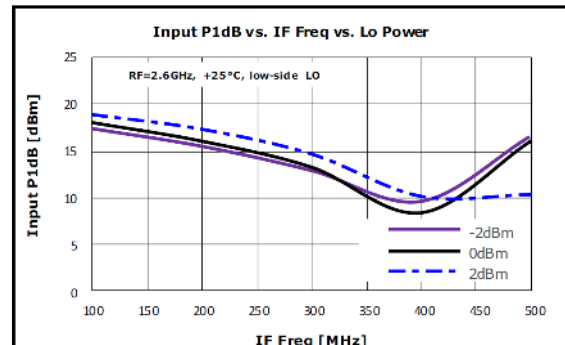
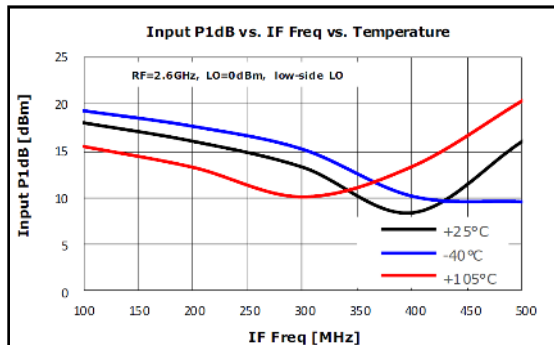
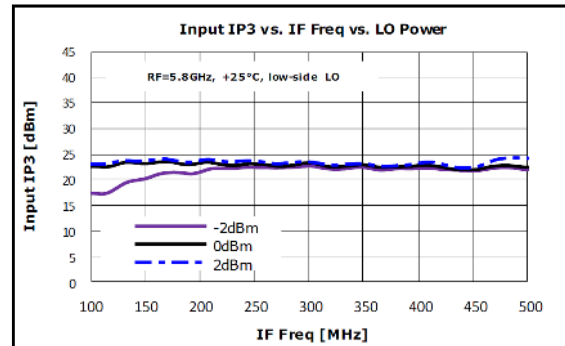
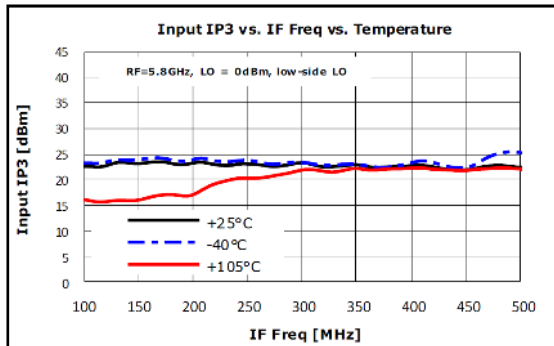
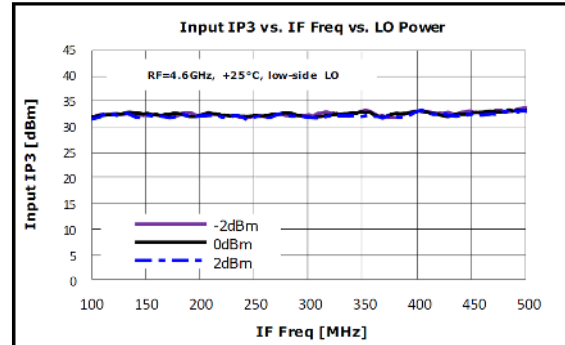
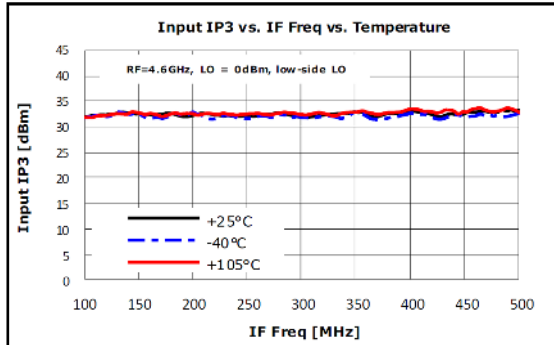

**Typical Test Data : 5V, IF to RF Converting**

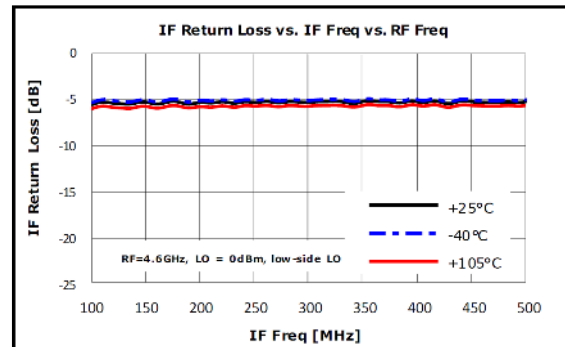
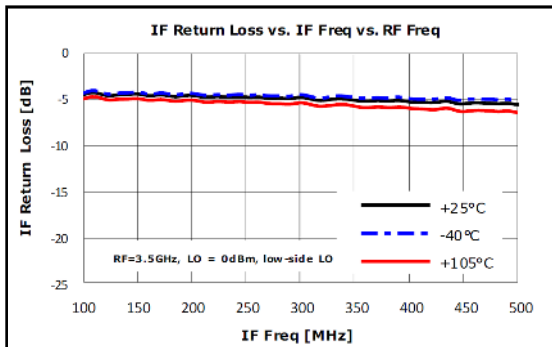
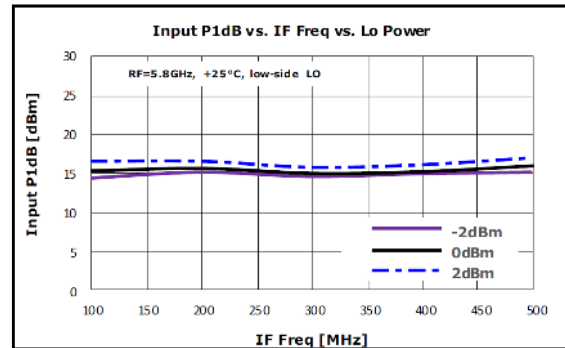
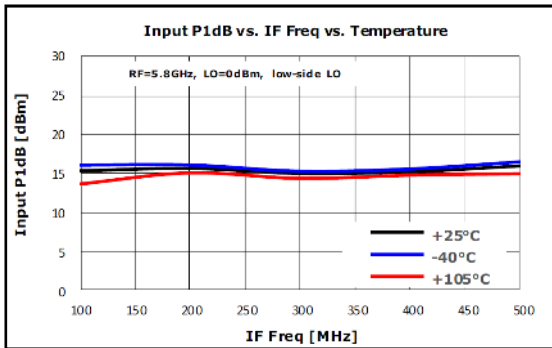
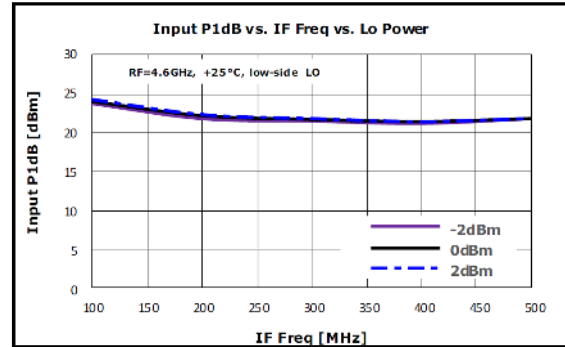
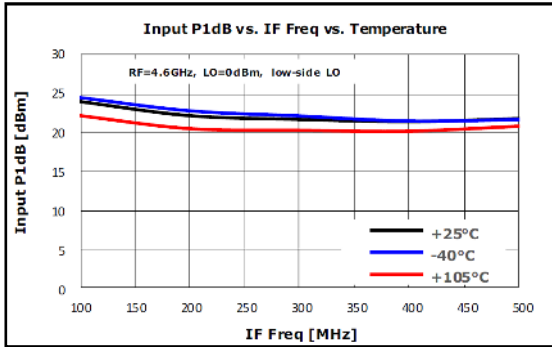
 Test condition : Measured on BeRex E/B at 25°C, 50ohm system, Vdd=5V, I<sub>ds</sub>=85mA , Up converting

**Typical Test Data : 3.3V, RF to IF Converting**

Test condition : Measured on BeRex E/B at 25°C, 50ohm system, Vdd=3.3V, I<sub>ds</sub>=62mA , Down converting

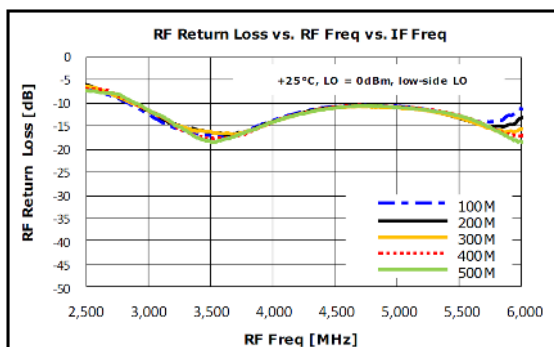
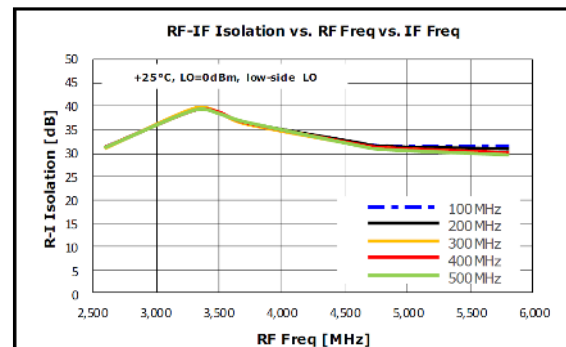
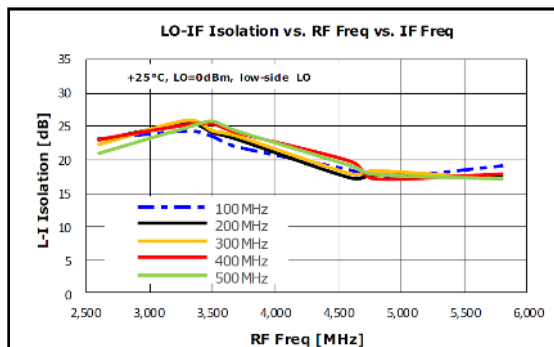
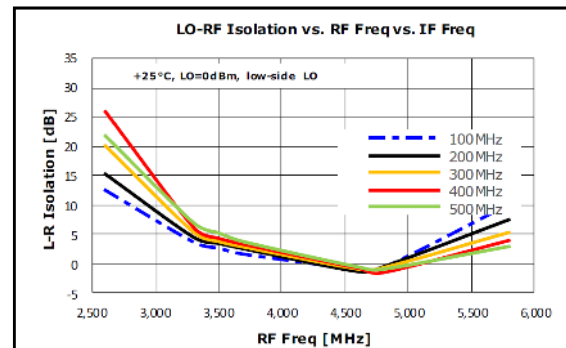
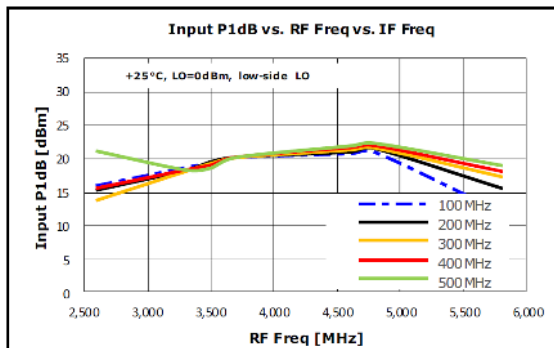
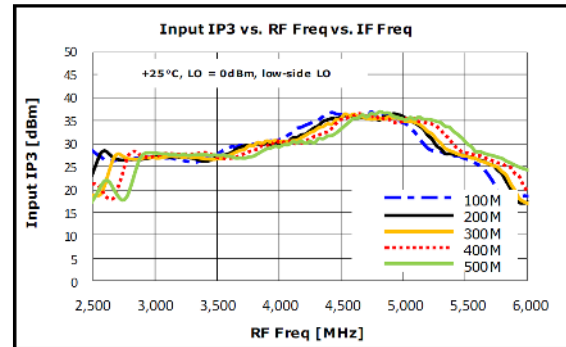
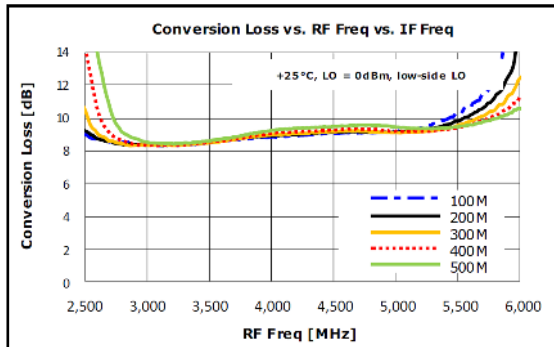

**Typical Test Data : 3.3V, RF to IF Converting**

Test condition : Measured on BeRex E/B at 25°C, 50ohm system, Vdd=3.3V, I<sub>ds</sub>=62mA , Down converting

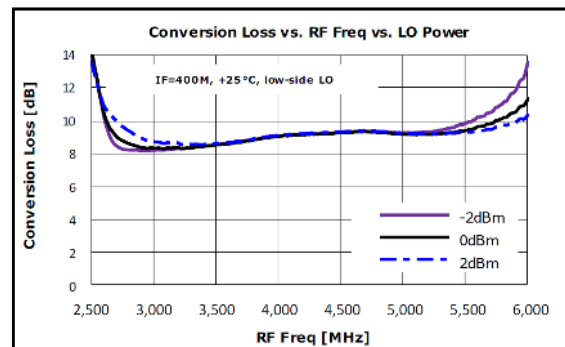
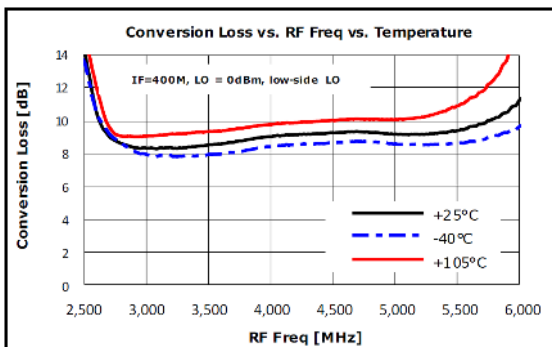
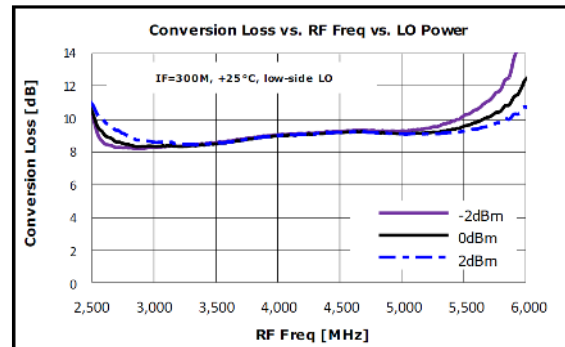
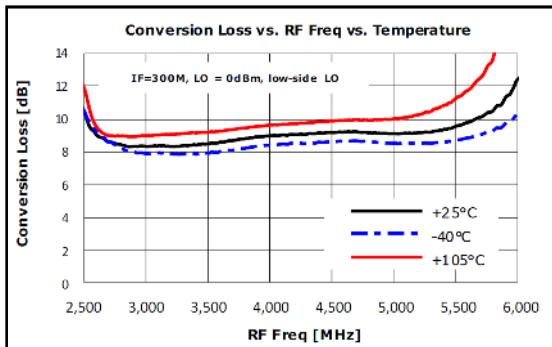
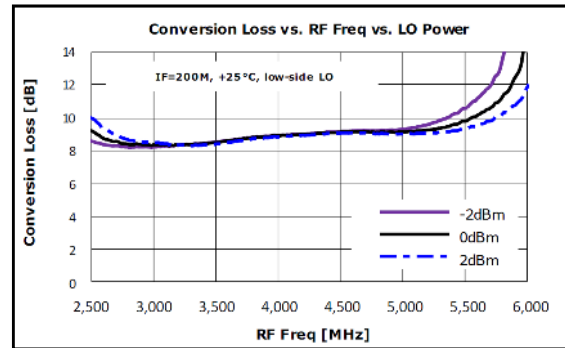
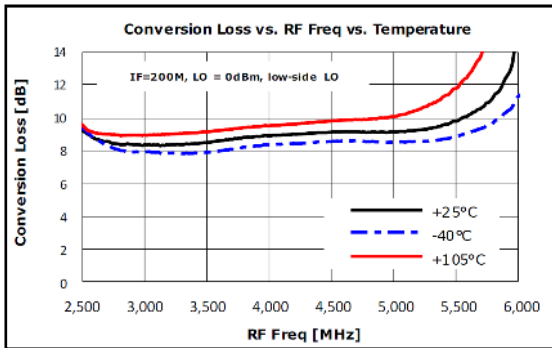
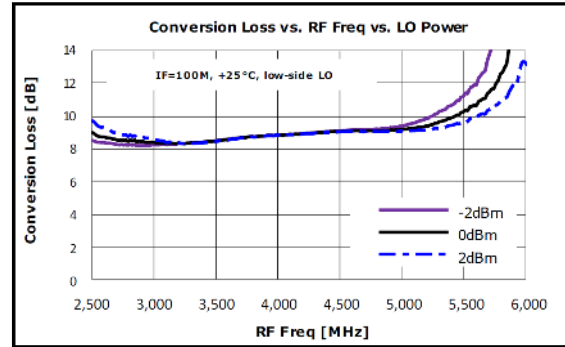
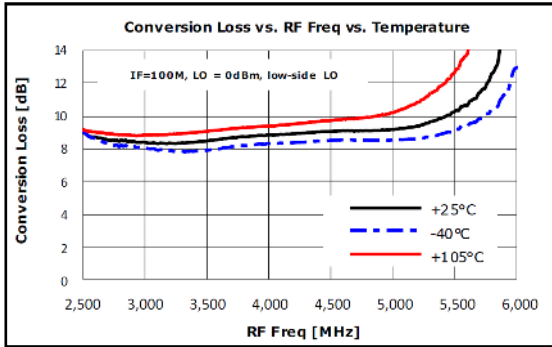

#### Typical Test Data : 3.3V, RF to IF Converting

Test condition : Measured on BeRex E/B at 25°C, 50ohm system, Vdd=3.3V, I<sub>ds</sub>=62mA , Down converting

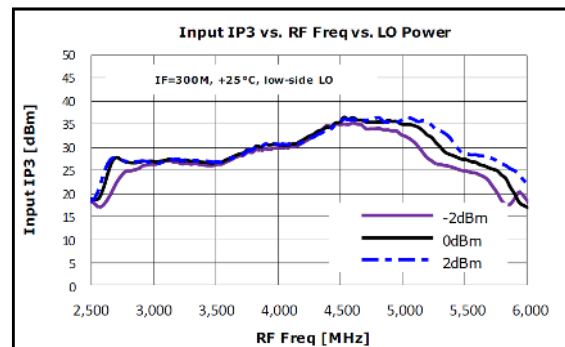
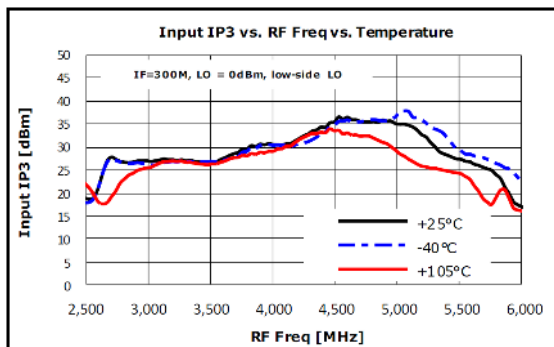
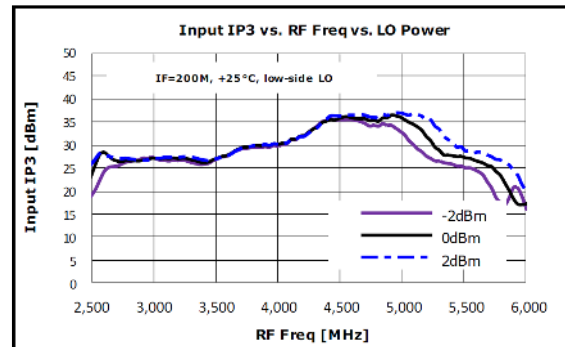
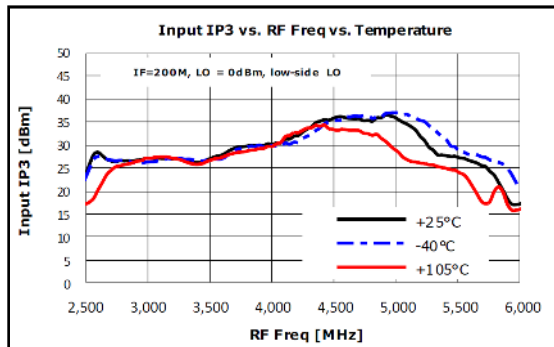
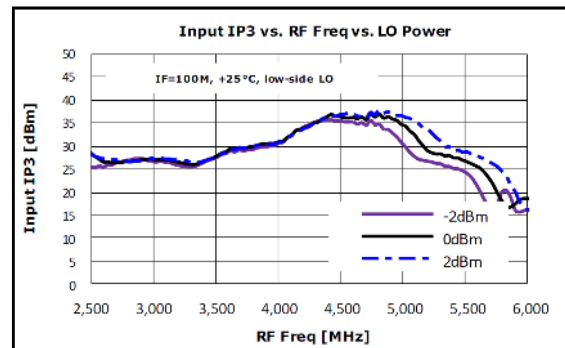
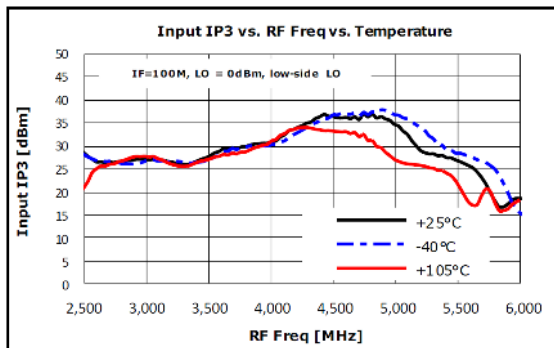
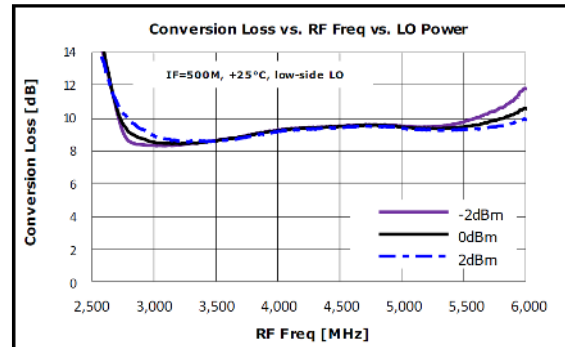
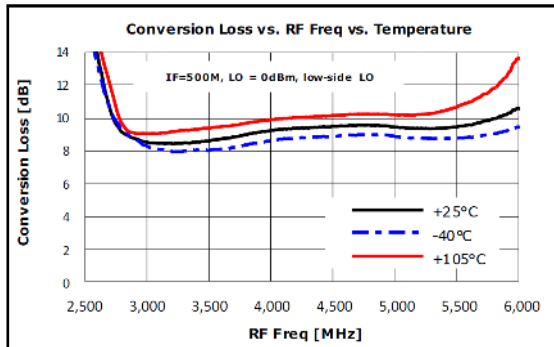

#### Typical Test Data : 3.3V, RF to IF Converting

Test condition : Measured on BeRex E/B at 25°C, 50ohm system, Vdd=3.3V, I<sub>ds</sub>=62mA , Down converting

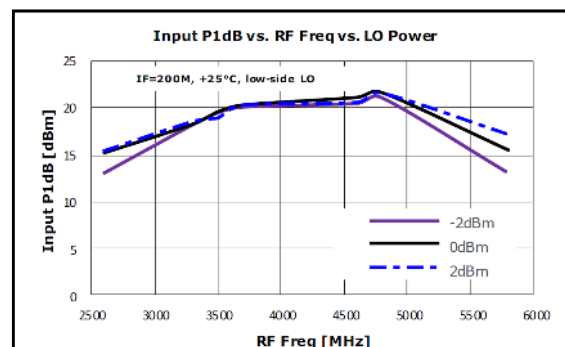
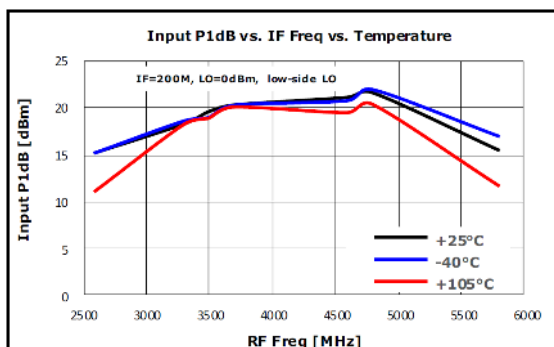
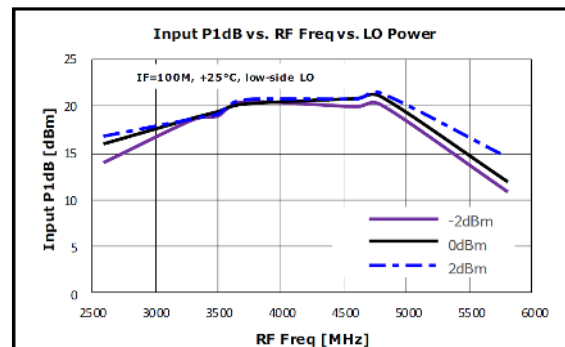
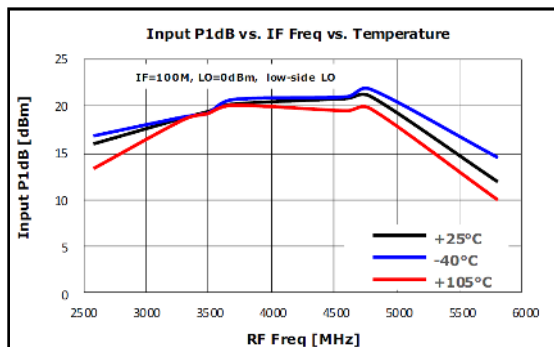
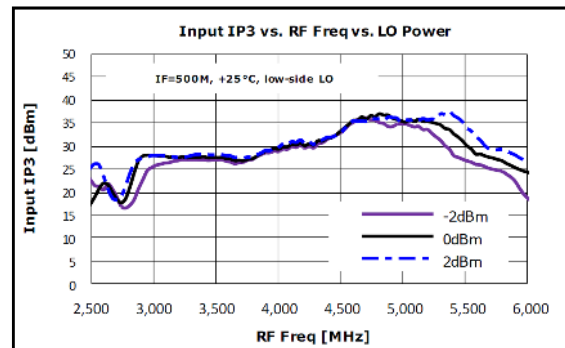
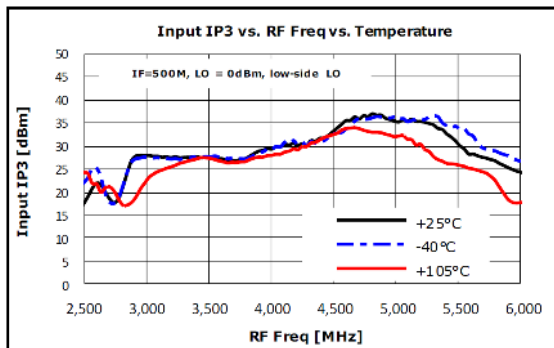
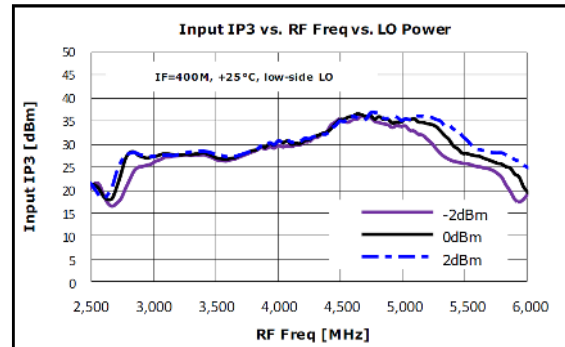
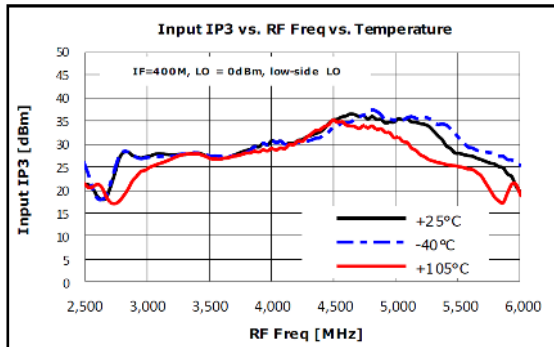

**Typical Test Data : 3.3V, RF to IF Converting**

Test condition : Measured on BeRex E/B at 25°C, 50ohm system, Vdd=3.3V, I<sub>ds</sub>=62mA , Down converting

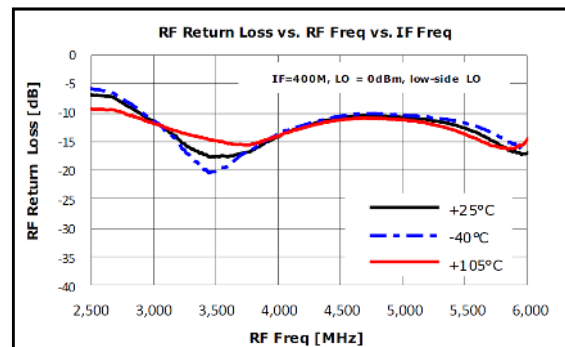
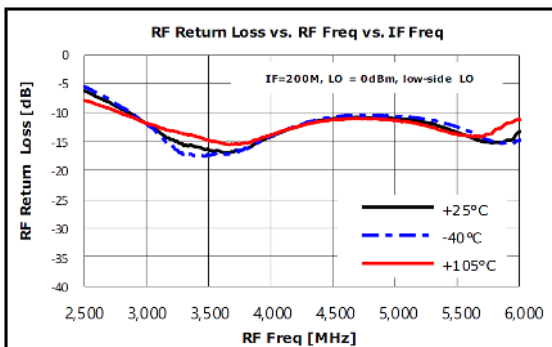
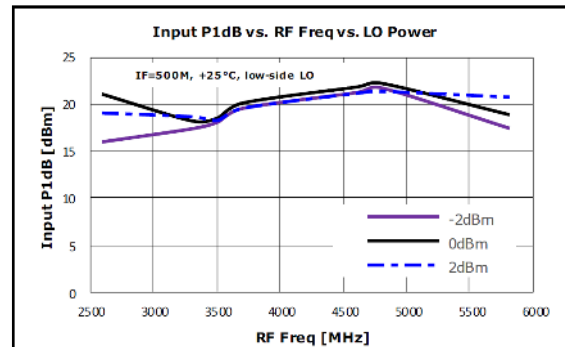
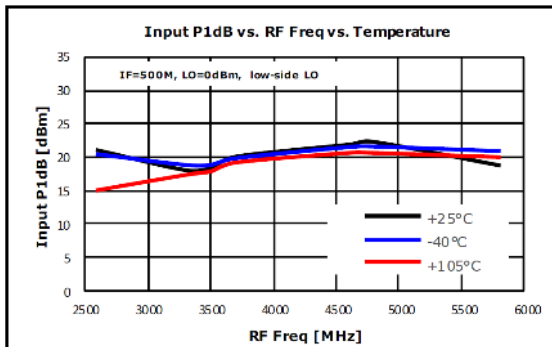
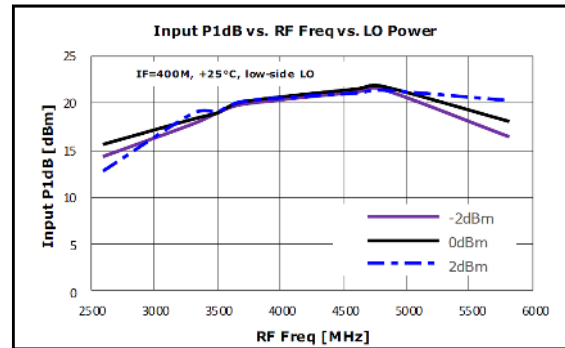
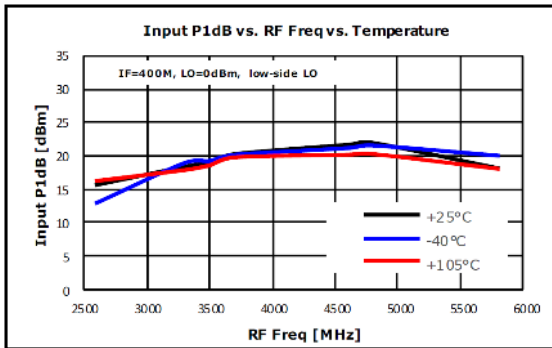
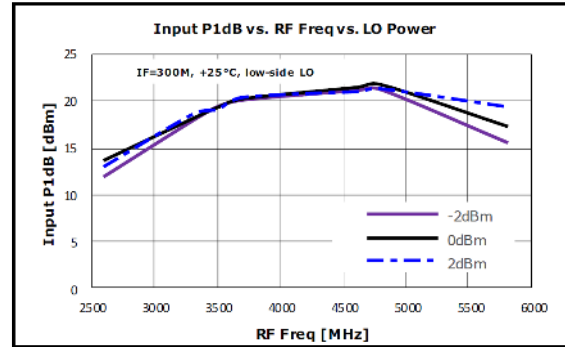
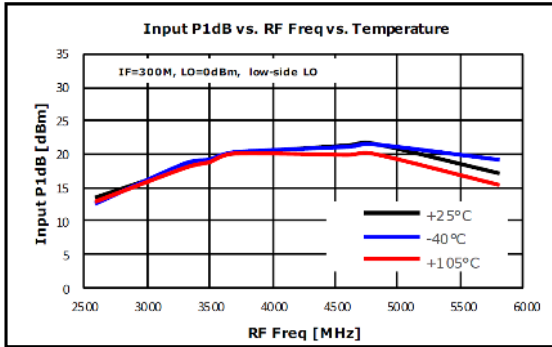



**Typical Test Data : 3.3V, IF to RF Converting**

Test condition : Measured on BeRex E/B at 25°C, 50ohm system, Vdd=3.3V, I<sub>ds</sub>=62mA , Up converting

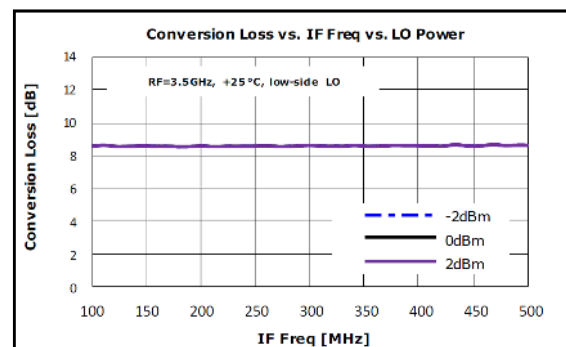
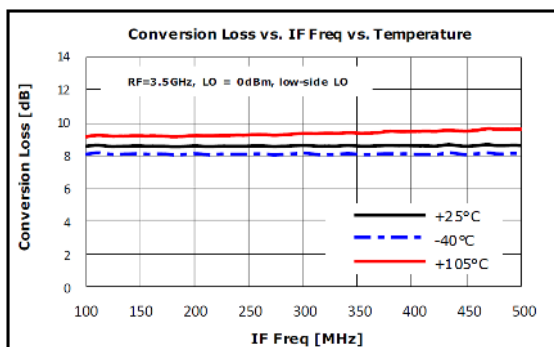
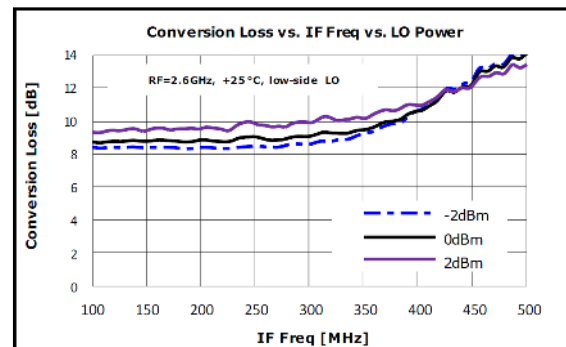
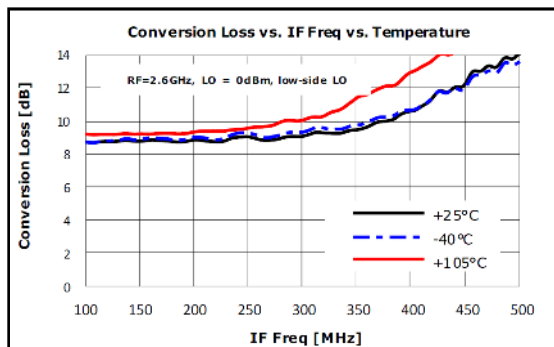
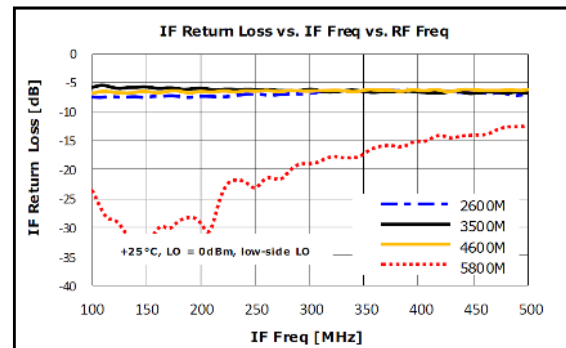
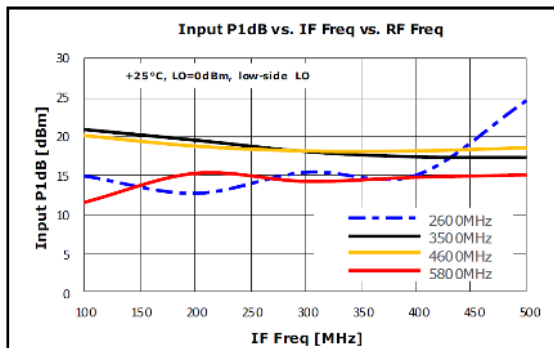
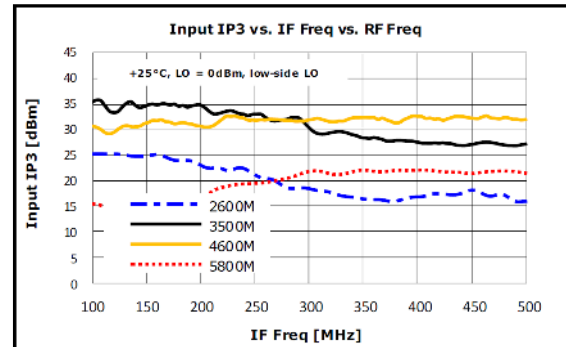
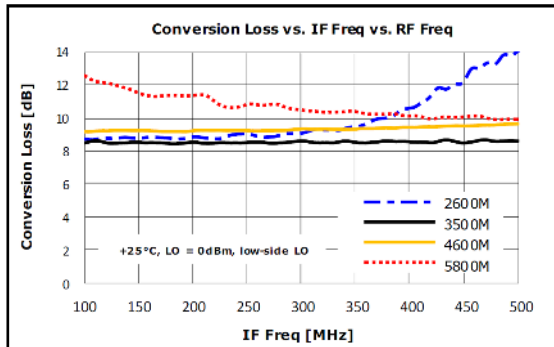

**Typical Test Data : 3.3V, IF to RF Converting**

Test condition : Measured on BeRex E/B at 25°C, 50ohm system, Vdd=3.3V, I<sub>ds</sub>=62mA , Up converting

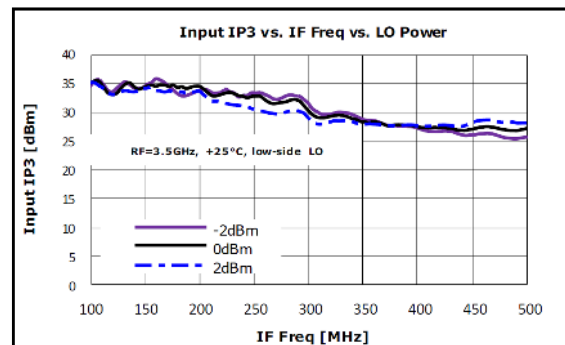
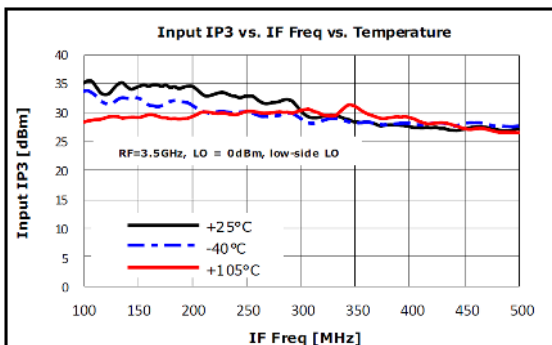
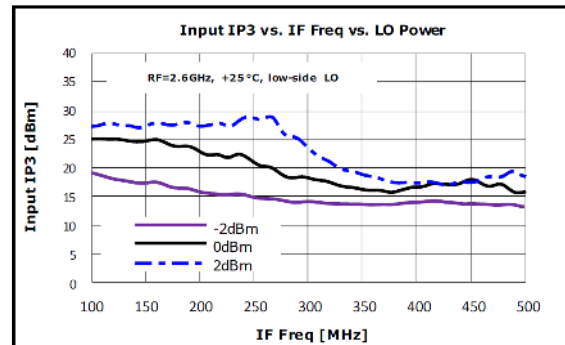
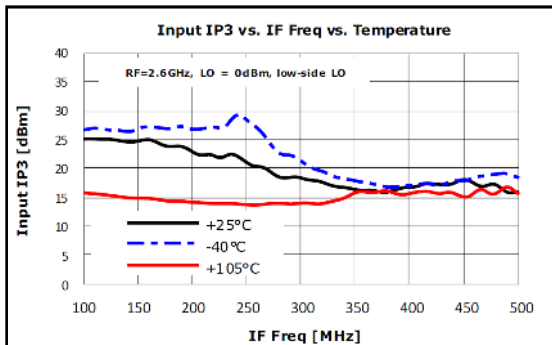
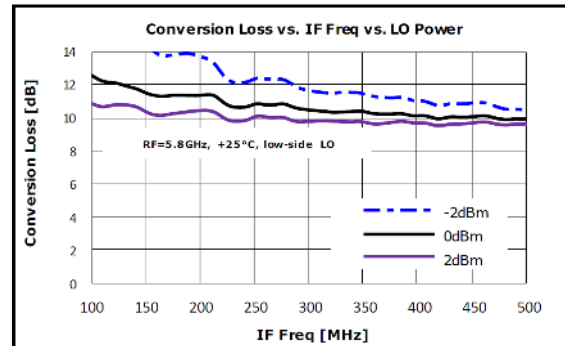
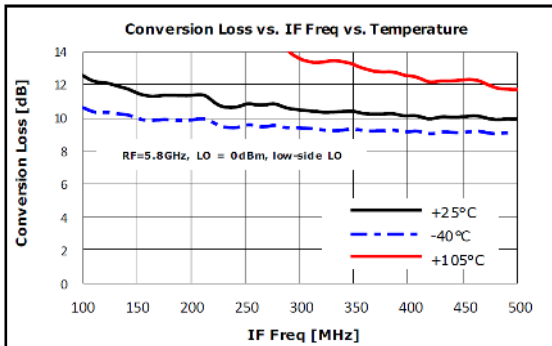
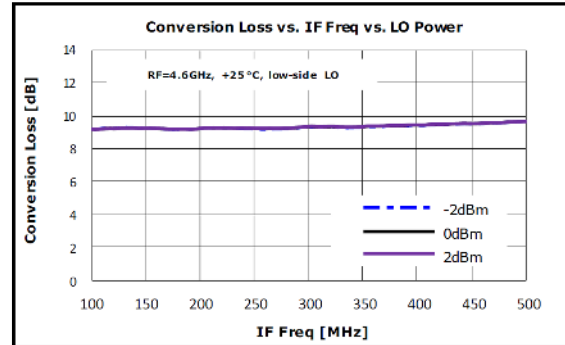
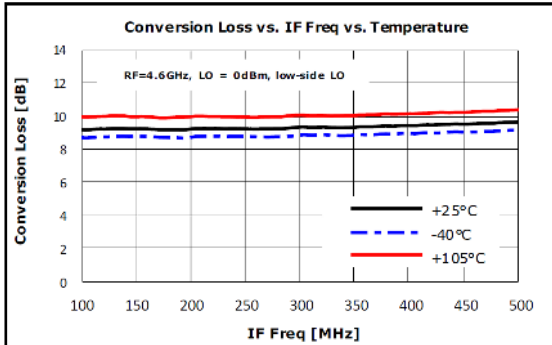

**Typical Test Data : 3.3V, IF to RF Converting**

Test condition : Measured on BeRex E/B at 25°C, 50ohm system, Vdd=3.3V, I<sub>ds</sub>=62mA , Up converting

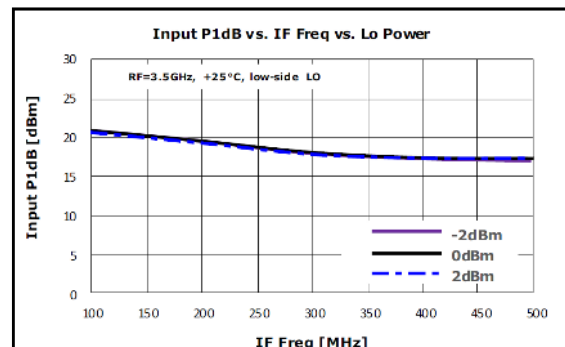
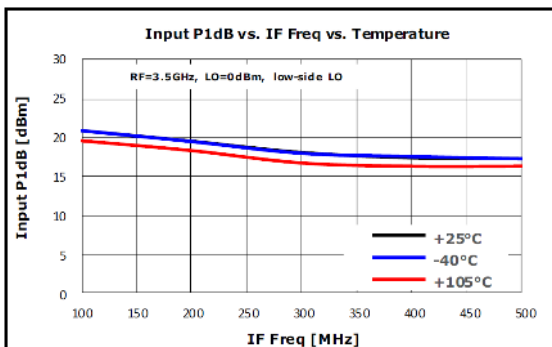
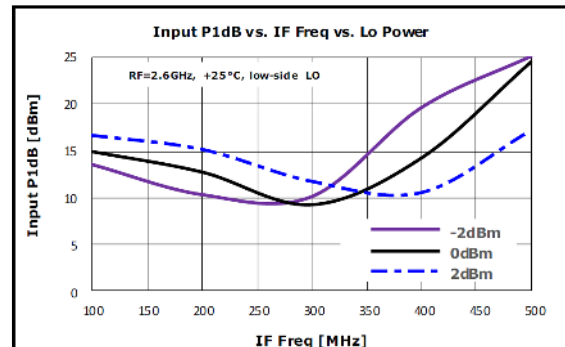
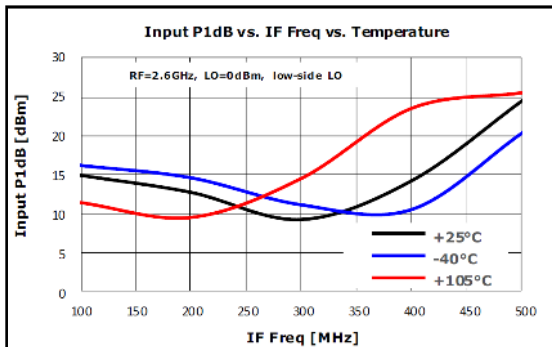
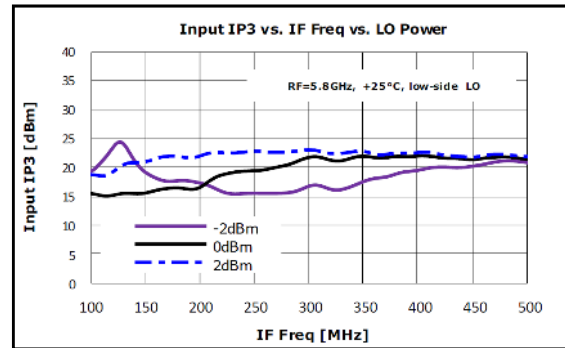
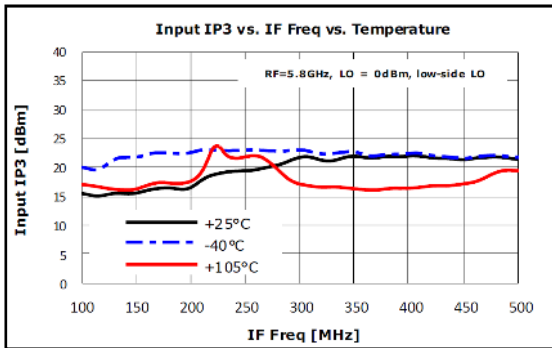
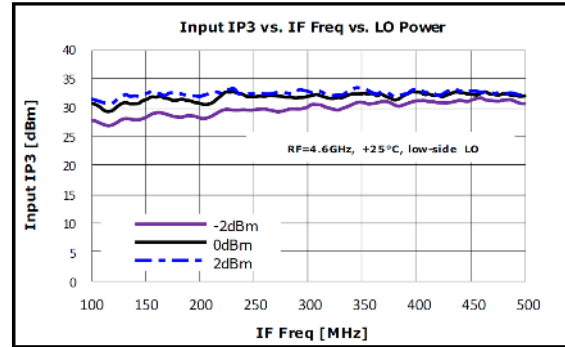
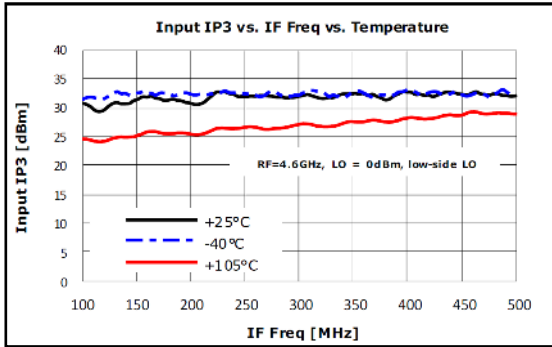

**Typical Test Data : 3.3V, IF to RF Converting**

Test condition : Measured on BeRex E/B at 25°C, 50ohm system, Vdd=3.3V, I<sub>ds</sub>=62mA , Up converting

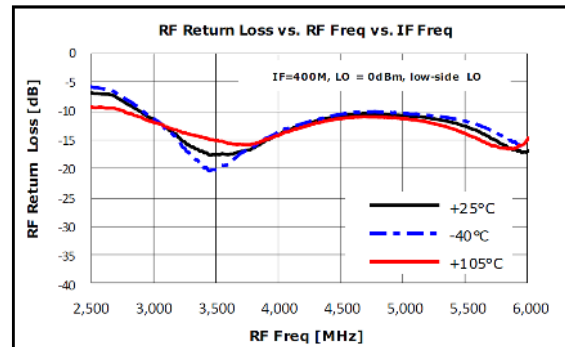
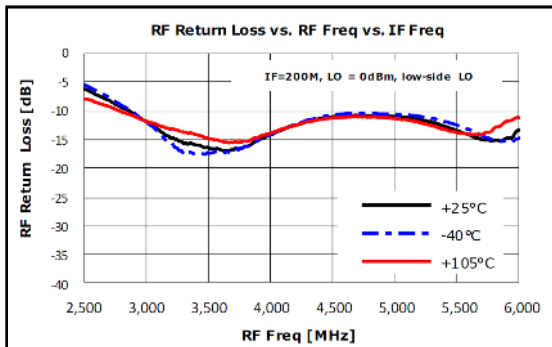
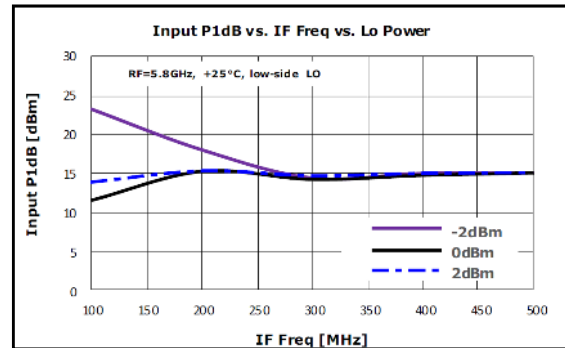
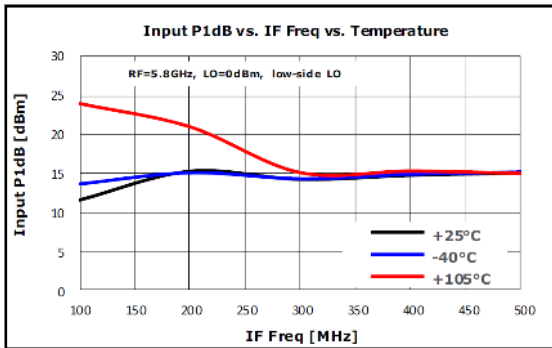
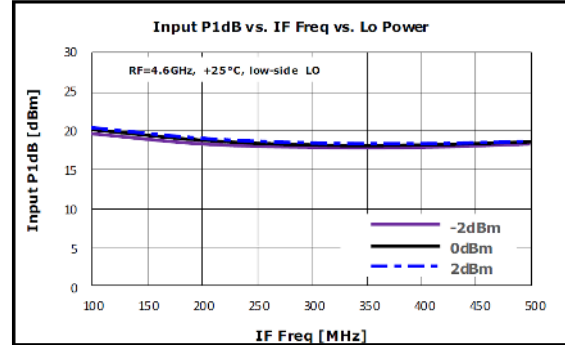
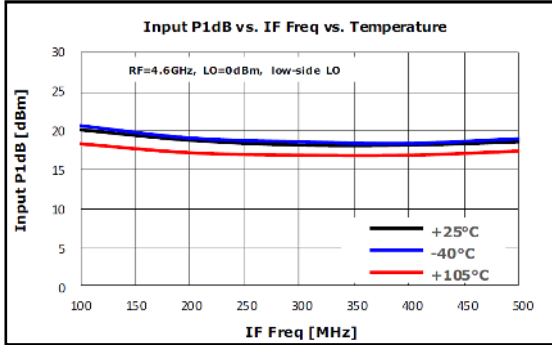

### Package Outline Drawing

A ORIGINAL ISSUE OCT13,2014

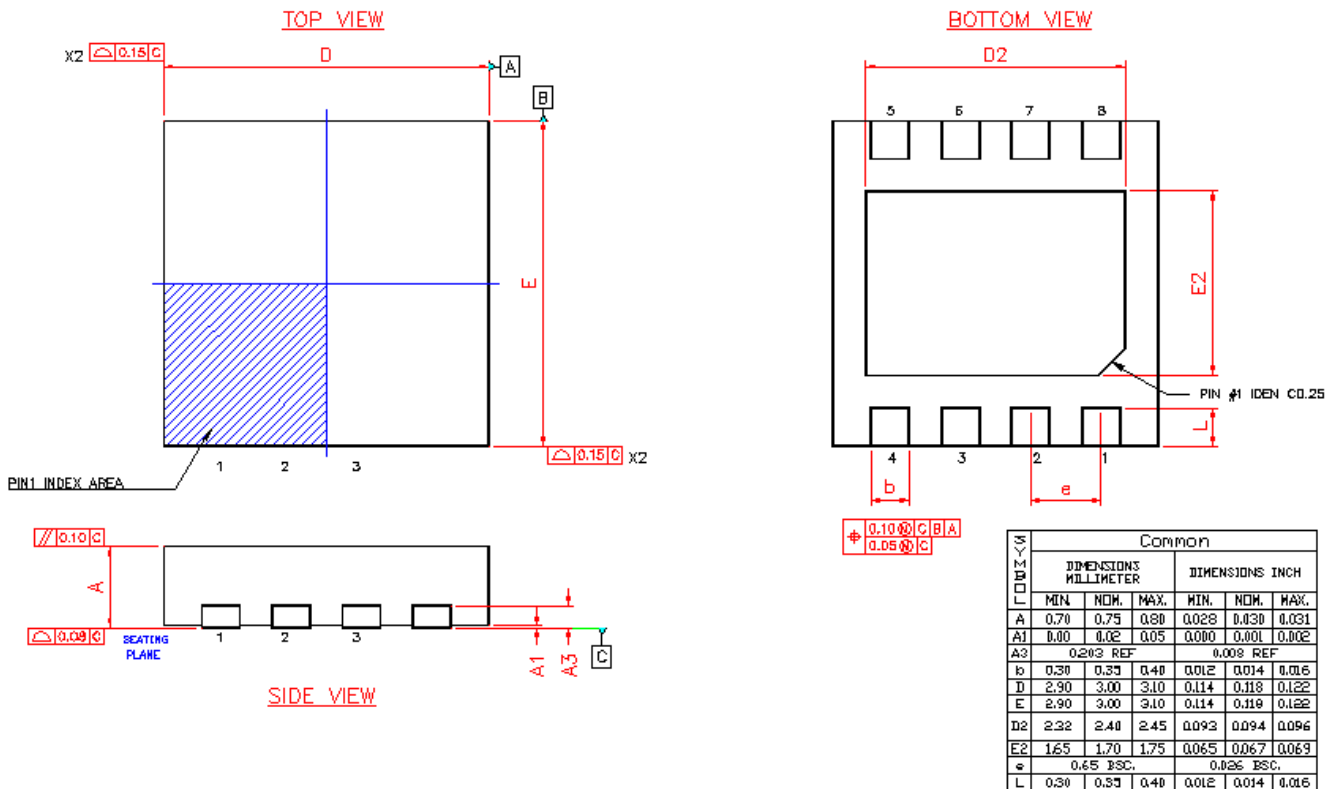

### Package Marking

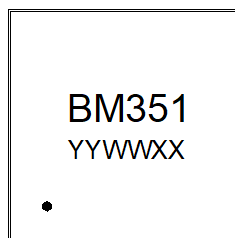

YY = Year, WW = Working Week,  
XX = Wafer No.

### Evaluation Board Drawing

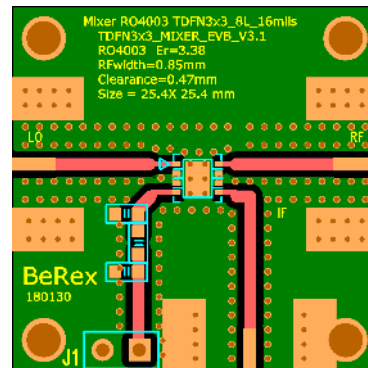

## Suggested PCB Land Pattern and PAD Layout

### PCB Land Pattern

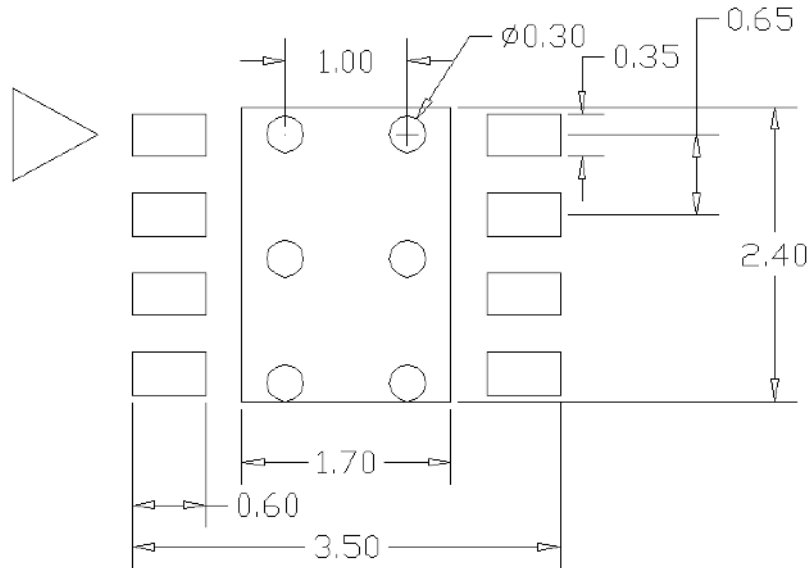

**Note :** 1. Connection to Bottom Ground with multiple via holes.

2. Via holes \_ as many as possible.
3. All Dimensions \_ millimeters.
4. PCB lay out \_ on BeRex website.

### Pin Configuration

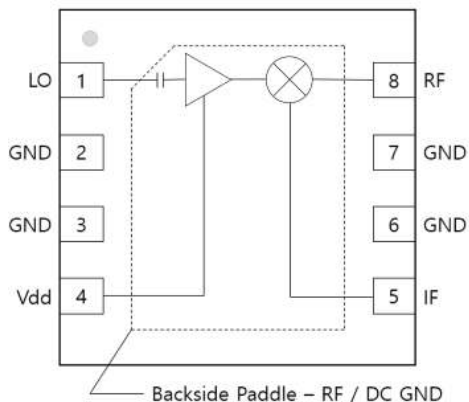

Pin No.	Label	Description
1	LO	Local Oscillator Injection. Internally DC Blocked
2,3,6,7	GND	RF/DC Ground.
4	Vdd	Power supply for LO amplifier
5	IF	Intermediate Frequency
8	RF	Radio Frequency
Backside Paddle	GND	RF/DC Ground. Follow recommended via pattern and ensure good solder attach for best thermal and electrical performance.

## Tape & Reel

TDFN-8L 3x3

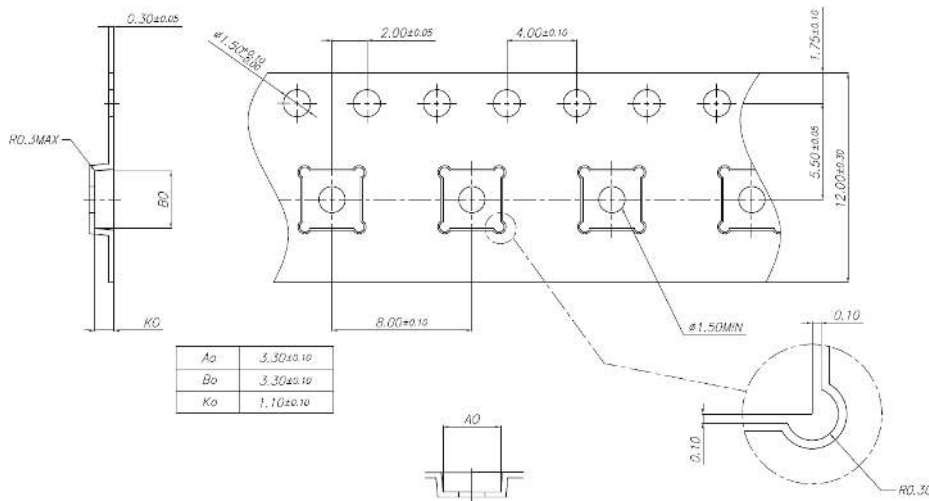

Packaging information :

Tape width(mm) : 12

Reel Size (inches) : 7

Device Cavity Pitch(mm) : 8

Devices Per Reel : 1000

## Lead plating finish

### 100% Tin Matte finish

(All BeRex products undergoes a 1 hour, 150 degree C, Anneal bake to eliminate thin whisker growth concerns.)

**MSL / ESD Rating**

<b>ESD Rating:</b>	Class 1A
<b>Value:</b>	<b>Passes &lt;500V</b>
<b>Test:</b>	Human Body Model (HBM)
<b>Standard:</b>	JEDEC Standard JS-001-2014
<b>MSL Rating:</b>	<b>Level 1 at +260°C convection reflow</b>
<b>Standard:</b>	JEDEC Standard J-STD-020



Proper ESD procedures should be followed when handling this device.

**RoHS Compliance**

This part is compliant with Restrictions on the Use of Certain Hazardous Substances in Electrical and Electronic Equipment (RoHS) Directive 2011/65/EU as amended by Directive 2015/863/EU.

This product also is compliant with a concentration of the Substances of Very High Concern (SVHC) candidate list which are contained in a quantity of less than 0.1%(w/w) in each components of a product and/or its packaging placed on the European Community market by the BeRex and Suppliers.

**NATO CAGE code:**

<b>2</b>	<b>N</b>	<b>9</b>	<b>6</b>	<b>F</b>
----------	----------	----------	----------	----------