

Approval Sheet

Customer	
Product Number	M1SF-12MC4103-J
Module speed	PC-3200
Pin	200 pin
CAS Latency	CL-3
SDRAM Operating Temp	-20 °C ~ 85 °C
Date	26 th November 2014

Approval by Customer

P/N:

Signature:

Date:

Sales: _____

Sr. Technical Manager: John Hsieh

Rev 1.1

1. Features

Key Parameter

Industry Nomenclature	Speed Grade	Data Rate MT/s			tRCD (ns)	tRP (ns)	tRC (ns)
		CL=2	CL=2.5	CL=3			
PC-3200	F	266	333	400	15	15	55

- JEDEC Standard 200-pin Dual In-Line Memory Module
- Intend for 400 MHz applications
- Inputs and Outputs are SSTL-2 compatible
- VDD=VDDQ= 2.6 Volt \pm 0.2 (PC-3200)
- Differential clock input
- DLL aligns DQ and DQS transition with CK transition
- Bi-Directional data strobe with one clock cycle
- Golden Connector (Au: 30 μ ".)
- Built with 512Mb DDR SDRAMs in 400 mil TSOP II packages
- Self-Refresh Modes support.
- Serial Presence Detect with EEPROM
- Self-refresh 7.8 μ s ($T_A \leq +70^\circ\text{C}$)
- SDRAM Operation Temperature
 - $-20^\circ\text{C} \leq T_A \leq +85^\circ\text{C}$
- Programmable Device Operation:
 - Burst Type: Sequential or Interleave
 - Device CAS# Latency: 2, 2.5 & 3
 - Burst Length: 2, 4 or 8
- RoHS Compliant (Section 13)

2. Environmental Requirements

iDIMM are intended for use in standard office environments that have limited capacity for heating and air conditioning.

Symbol	Parameter	Rating	Units	Notes
ToPR	Operating Temperature (ambient)	-20 to +85	°C	1
TstG	Storage Temperature	-50 to +100	°C	1

1. The component maximum case temperature (Tcase) shall not exceed the value specified in the DDR DRAM component specification.

3. Ordering Information

Extend Temperature DDR SODIMM						
Part Number	Density	Speed	DIMM Organization	Number of DRAM	Number of rank	ECC
M1SF-12MC4103-J	512MB	PC-3200	64M x64	8	1	N/A

4. Pin Configurations (Front side/Back side)

Pin	Front	Pin	Back	Pin	Front	Pin	Back	Pin	Front	Pin	Back	Pin	Front	Pin	Back
1	V _{REF}	101	A9	26	DM1	126	V _{SS}	51	V _{SS}	151	DQ42	76	V _{SS}	176	DQ55
2	V _{REF}	102	A8	27	V _{SS}	127	DQ32	52	V _{SS}	152	DQ46	77	DQS8	177	DQ56
3	V _{SS}	103	V _{SS}	28	V _{SS}	128	DQ36	53	DQ19	153	DQ43	78	DM8	178	DQ60
4	V _{SS}	104	V _{SS}	29	DQ10	129	DQ33	54	DQ23	154	DQ47	79	CB2	179	V _{DD}
5	DQ0	105	A7	30	DQ14	130	DQ37	55	DQ24	155	V _{DD}	80	CB6	180	V _{DD}
6	DQ4	106	A6	31	DQ11	131	V _{DD}	56	DQ28	156	V _{DD}	81	V _{DD}	181	DQ57
7	DQ1	107	A5	32	DQ15	132	V _{DD}	57	V _{DD}	157	V _{DD}	82	V _{DD}	182	DQ61
8	DQ5	108	A4	33	V _{DD}	133	DQS4	58	V _{DD}	158	/CK1	83	CB3	183	DQS7
9	V _{DD}	109	A3	34	V _{DD}	134	DM4	59	DQ25	159	V _{SS}	84	CB7	184	DM7
10	V _{DD}	110	A2	35	CK0	135	DQ34	60	DQ29	160	CK1	85	DU	185	V _{SS}
11	DQS0	111	A1	36	V _{DD}	136	DQ38	61	DQS3	161	V _{SS}	86	DU/Reset	186	V _{SS}
12	DM12	112	A0	37	/CK0	137	V _{SS}	62	DM3	162	V _{SS}	87	V _{SS}	187	DQ58
13	DQ2	113	V _{DD}	38	V _{SS}	138	V _{SS}	63	V _{SS}	163	DQ48	88	V _{SS}	188	DQ62
14	DQ6	114	V _{DD}	39	V _{SS}	139	DQ35	64	V _{SS}	164	DQ52	89	CK2	189	DQ59
15	V _{SS}	115	A10/AP	40	V _{SS}	140	DQ39	65	DQ26	165	DQ49	90	V _{SS}	190	DQ63
16	V _{SS}	116	BA1	41	DQ16	141	DQ40	66	DQ30	166	DQ53	91	CK2	191	V _{DD}
17	DQ3	117	BA0	42	DQ20	142	DQ44	67	DQ27	167	V _{DD}	92	V _{DD}	192	V _{DD}
18	DQ7	118	RAS	43	DQ17	143	V _{DD}	68	DQ31	168	V _{DD}	93	V _{DD}	193	SDA
19	DQ8	119	WE	44	DQ21	144	V _{DD}	69	V _{DD}	169	DQS6	94	V _{DD}	194	SA0
20	DQ12	120	CAS	45	V _{DD}	145	DQ41	70	V _{DD}	170	DM6	95	CKE1	195	SCL
21	V _{DD}	121	/S0	46	V _{DD}	146	DQ45	71	CB0	171	DQ50	96	CKE0	196	SA1
22	V _{DD}	122	/S1	47	DQS2	147	DQS5	72	CB4	172	DQ54	97	DU	197	V _{DD} SPD
23	DQ9	123	DU (A13)	48	DM2	148	DM5	73	CB1	173	V _{SS}	98	DU	198	SA2
24	DQ13	124	DU	49	DQ18	149	V _{SS}	74	CB5	174	V _{SS}	99	A12	199	V _{DD} ID
25	DQS1	125	V _{SS}	50	DQ22	150	V _{SS}	75	V _{SS}	175	DQ51	100	A11	200	DU

Pins 71, 72, 73, 74, 77, 78, 79, 80, 83, 84 are reserved for x72 variants of this module and are not used on the x64 versions.
 1. Pin 86 is reserved for a registered variant of this module and is not used on the unbuffered version.
 2. Pins 89, 91 are reserved for x72 modules or registered modules.
 3. Pin 123 reserved for higher density memories, requiring A13

5. Architecture

Pin Definition

Pin Name	Description	Pin Name	Description
A0 - A13 (A14 or A15)	SDRAM address bus	CK0 – CK1 /CK0 - /CK1	Differential SDRAM Clocks
BA0 - BA1 (or BA2)	SDRAM Bank Address Inputs	SCL	Serial Presence Detect Clock Input
RAS#	SDRAM row address strobe	SDA	Serial Presence Detect Data input/output
CAS#	SDRAM column address strobe	SA0 – SA1	Serial Presence Detect Address Inputs
WE#	SDRAM write enable	V _{DD}	Power Supply
S0# - S1#	DIMM Rank Select Lines	V _{DDID}	V _{DD} Identification Flag
CK0 – CK1	SDRAM clock enable lines	V _{DDQ}	SDRAM I/O Driver power supply
DQ0 – DQ63	DIMM memory data bus	V _{REF}	SDRAM I/O Reference supply
CB0 – CB7	DIMM ECC check bit	V _{SS}	Ground
DQS0 – DQS17	SDRAM data strobes	V _{DDSPD}	Serial EEPROM positive power supply
DM0 – DM7	SDRAM data masks	Reset	Reset enable
NC	Spare Pin		

6. Function Block Diagram: - (512B, 1 Rank 64Mx8 DDR SODIMM)

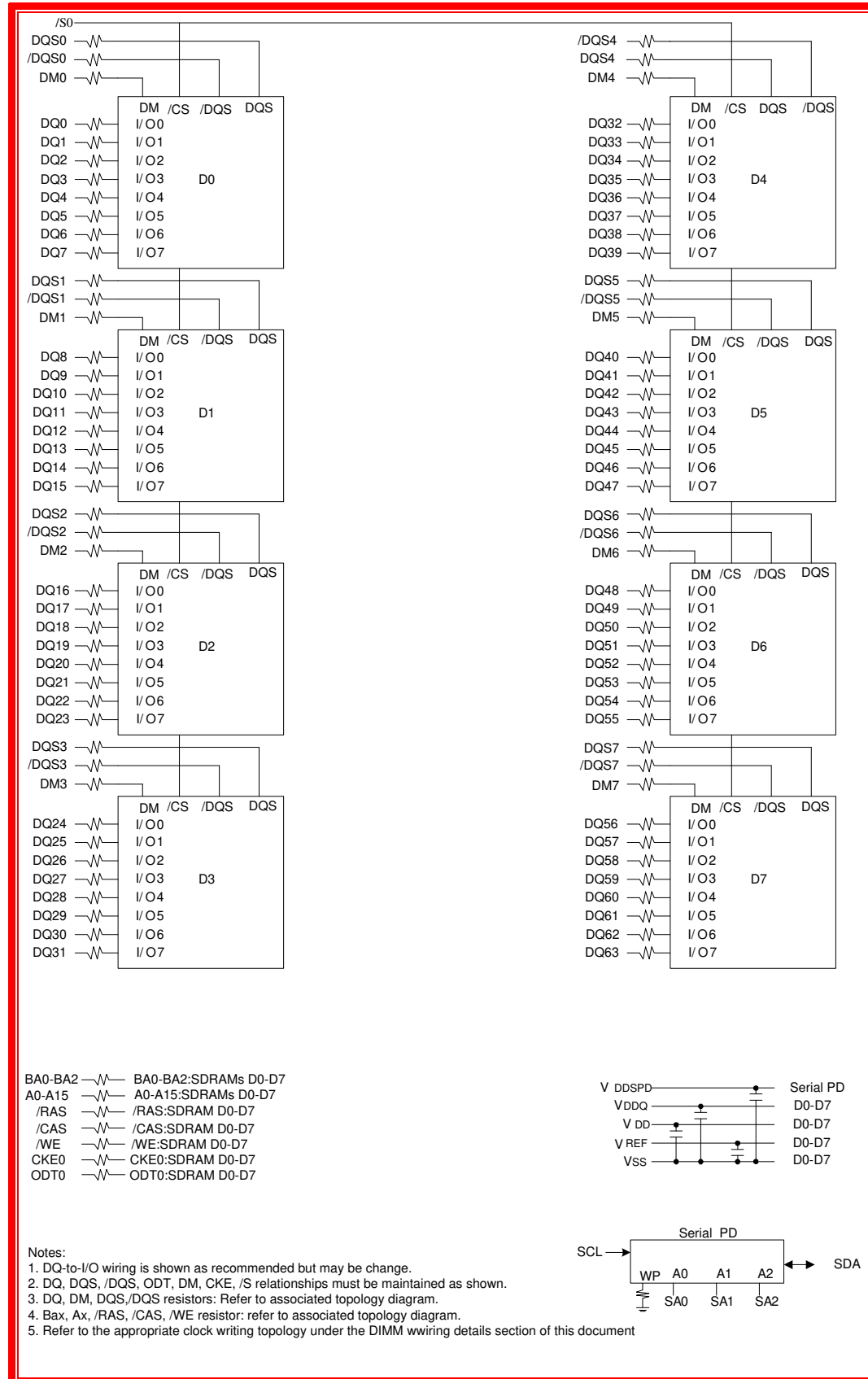

7. SDRAM Absolute Maximum Ratings

Symbol	Parameter	Rating	Units
T _A	Operation Temperature	-20 to 85	°C
T _{STG}	Storage Temperature	-55 to 150	°C
V _{INPUT}	Voltage input pins relative to V _{ss}	-1.0 to +3.6	V
V _{IO}	Voltage on I/O pins relative to V _{ss}	-0.5 to +3.6	V
V _{DD}	Voltage on VDD supply relative to V _{ss}	-1.0 to +3.6	V
V _{DDQ}	Voltage on VDDQ supply relative to V _{ss}	-1.0 to +3.6	V
I _{OS}	Output short Circuit Current	50	mA

Note: Stresses greater than those listed under "Absolute Maximum Ratings" may cause permanent damage to the device. This is stress rating only, and functional operation of the device at these or any other conditions above those indicated in the operational sections of this specification is not implied. Exposure to absolute maximum rating conditions for extended periods may affect reliability.

8. AC & DC Operating Conditions

- AC Operating Conditions

(T_{CASE} = -20 °C ~ 85 °C; V_{SS} = 0V)

Symbol	Parameter	Value		Units	Notes
		Min	Max		
V _{IH} (AC)	Input High (Logic1) Voltage	V _{REF} + 0.31	-	V	
V _{IL} (AC)	Input Low (Logic0) Voltage	-	V _{REF} + 0.31	V	
V _{ID} (AC)	Input differential Voltage: CK, /CK	0.7	V _{DDQ} + 0.6	V	1
V _{IX} (AC)	Input crossing point Voltage: CK, /CK	0.5* V _{DDQ} + 0.2	0.5* V _{DDQ} - 0.2	V	2

Note:

- VID is the magnitude of the difference between the input level on CK and the input on /CK.
- The value of VIX is expected to equal 0.5*V_{DDQ} of the transmitting device and must track variations in the DC level of the same.

- DC Electrical Characteristics and Operating Conditions

($T_{CASE} = -20\text{ }^{\circ}\text{C} \sim 85\text{ }^{\circ}\text{C}$; $V_{SS} = 0\text{V}$)

Symbol	Parameter	Min	Typ.	Max	Units	Notes
VDD	Supply Voltage (DDR266,333)	2.5	2.6	2.7	V	
	Supply Voltage (DDR400)	2.5	2.6	2.7	V	
VDDQ	Supply Voltage (DDR266,333)	2.3	2.5	2.7	V	
	Supply Voltage (DDR400)	2.5	2.6	2.7	V	
VIH (DC)	Input High (Logic1) Voltage	$V_{REF} + 0.15$	-	$V_{DDQ} + 0.3$	V	1
VIL (DC)	Input Low (Logic0) Voltage	-0.3	-	$V_{REF} - 0.15$	V	1
VTT	Termination Voltage	$V_{REF} - 0.04$	V_{REF}	$V_{REF} + 0.04$	V	3
VREF	I/O Reference Voltage	$0.49V_{DDQ}$	$0.5V_{DDQ}$	$0.51V_{DDQ}$	V	2
VIN(DC)	Input Voltage Level: CK, /CK	-0.3	-	$V_{DDQ} + 0.3$	V	
VID(DC)	Input Differential Voltage: CK, /CK	0.36	-	$V_{DDQ} + 0.6$	V	
VI(RATIO)	V-I Matching	0.71	-	1.4	V	

Note:

- Inputs are not recognized as valid until VREF stabilizes.
- VREF is expected to be equal to 0.5 V DDQ of the transmitting device, and to track variations in the DC level of the same. Peak-to-peak noise on VREF may not exceed 2% of the DC value.
- VTT of transmitting device must track VREF of receiving device.

9. Operating, Standby, and Refresh Currents

- 512MB SODIMM (1 Rank, 64Mx8 DDR SDRAMs $T_{CASE} = -20\text{ }^{\circ}\text{C} \sim 85\text{ }^{\circ}\text{C}$)

Symbol	Parameter/Condition	PC-3200	Unit
I DD0	One bank; Active - Precharge; $t_{RC}=t_{RC}(\text{min})$; $t_{CK}=t_{CK}(\text{min})$; DQ,DM and DQS inputs changing twice per clock cycle; address and control inputs changing once per clock cycle	760	mA
I DD1	One bank; Active - Read - Precharge; Burst Length=2; $t_{RC}=t_{RC}(\text{min})$; $t_{CK}=t_{CK}(\text{min})$; address and control inputs changing once per clock cycle	920	mA
I DD2P	All banks idle; Power down mode; $\text{CKE}=\text{Low}$, $t_{CK}=t_{CK}(\text{min})$	80	mA
I DD2F	$/\text{CS}=\text{High}$, All banks idle; $t_{CK}=t_{CK}(\text{min})$; $\text{CKE}=\text{High}$; address and control inputs changing once per clock cycle. $V_{IN}=V_{REF}$ for DQ, DQS and DM	280	mA
I DD3P	One bank active ; Power down mode; $\text{CKE}=\text{Low}$, $t_{CK}=t_{CK}(\text{min})$	360	mA
I DD3N	$/\text{CS}=\text{HIGH}$; $\text{CKE}=\text{HIGH}$; One bank; Active-Precharge; $t_{RC}=t_{RAS}(\text{max})$; $t_{CK}=t_{CK}(\text{min})$; DQ, DM and DQS inputs changing twice per clock cycle; Address and other control inputs changing once per clock cycle	480	mA
I DD4R	Burst=2; Reads; Continuous burst; One bank active; Address and control inputs changing once per clock cycle; $t_{CK}=t_{CK}(\text{min})$; $\text{IOUT}=0\text{mA}$	1080	mA
I DD4W	Burst=2; Writes; Continuous burst; One bank active; Address and control inputs changing once per clock cycle; $t_{CK}=t_{CK}(\text{min})$; DQ, DM and DQS inputs changing twice per clock cycle	1160	mA
I DD5	$t_{RC}=t_{RFC}(\text{min}) - 8*t_{CK}$ for DDR200 at 100Mhz, $10*t_{CK}$ for DDR266A & DDR266B at 133Mhz; distributed refresh	1280	mA
I DD6	$\text{CKE} < 0.2\text{V}$; External clock on; $t_{CK}=t_{CK}(\text{min})$	40	mA
I DD7	Four bank interleaving with BL=4 Refer to the following page for detailed test condition	1680	mA

10. AC Timing Specifications

(T_{CASE} = -20 °C ~ 85 °C; V_{DDQ} = V_{DD}, See AC Characteristics)

Symbol	Parameter	PC2-3200		Unit
		Min.	Max.	
tAC	DQ output access time from CK/CK#	-0.7	0.7	ns
tDQSK	DQS output access time from CK/CK#	-0.55	0.55	ns
tCH	CK high-level width	0.45	0.55	tCK
tCL	CK low-level width	0.45	0.55	tCK
tHP	Minimum half clk period for any given cycle; defined by clk high (tCH) or clk low (tCL) time	min (tCL,tCH)	-	ns
tCK	Clock Cycle Time	5	10	ns
tDS	DQ and DM input setup time(differential data strobe)	0.4	-	ns
tDH	DQ and DM input hold time(differential data strobe)	0.4	-	ns
tIPW	Input pulse width	2.2	-	ns
tDIPW	DQ and DM input pulse width (each input)	1.75	-	ns
tHZ	Data-out high-impedance time from CK/CK	-0.7	0.7	ns
tLZ(DQS)	DQS low-impedance time from CK/CK	-0.7	0.7	ns
tLZ(DQ)	DQ low-impedance time from CK/CK	-0.7	0.7	ns
tDQSQ	DQS-DQ skew (DQS & associated DQ signals)	-	0.4	ns
tQHS	Data hold Skew Factor	-	0.5	ns
tQH	Data output hold time from DQS	tHP -tQHS	-	ns
tDQSS	Write command to 1st DQS latching transition	0.72	1.25	tCK
tDQSL,(H)	DQS input low (high) pulse width (write cycle)	0.35	-	tCK
tDSS	DQS falling edge to CK setup time (write cycle)	0.35	-	tCK
tDSH	DQS falling edge hold time from CK (write cycle)	0.4	-	tCK
tMRD	Mode register set command cycle time	2	-	tCK
tWPST	Write postamble	0.4	0.6	tCK
tWPRE	Write preamble	0.9	1.1	tCK
tIH	Address and control input hold time	0.6	-	ns

tIS	Address and control input setup time	0.7	-	ns
tRPRE	Read preamble	0.9	1.1	tCK
tRPST	Read postamble	0.4	0.6	tCK
tRRD	Active bank A to Active bank B command	10	-	ns
tREFI	Average Periodic Refresh Interval (85°C < T _{CASE} ≤ 95°C)	-	3.9	µs
	Average Periodic Refresh Interval (0°C ≤ T _{CASE} ≤ 85°C)	-	7.8	µs
tCCD	CAS# to CAS# delay	15	-	tCK
tWR	Write recovery time without Auto-Precharge	15		ns
tDAL	Auto precharge write recovery + precharge time	$(tWR/tCK) + (tRP/tCK)$	-	tCK
tWTR	Internal write to read command delay	2	-	ns
tXSNR	Exit self refresh to a Non-read command	75	-	ns
tXSRD	Exit self refresh to a Read command	200	-	tCK
tCKE	CKE minimum pulse width			tCK

11.SPD Serial Presence Detect –(512MB)

64Mx64 1 RANK UNBUFFERED DDR SDRAM DIMM based on 64Mx8, 4Banks, 4K Refresh, 2.6V with SPD

Byte	Description	Serial PD Data Entry (Hexadecimal)	Note
0	Number of Serial PD Bytes Written during Production	80	
1	Total Number of Bytes in Serial PD device	08	
2	Fundamental Memory Type	07	
3	Number of Row Addresses on Assembly	0D	
4	Number of Column Addresses on Assembly	0B	
5	Number of DIMM Bank, Package, and Height	01	
6	Data Width of this Assembly	40	
7	Reserved	00	
8	Voltage Interface Level of this Assembly	04	
9	DDR SDRAM Cycle Time at CL=5 (ns)	50	
10	DDR SDRAM Access Time from Clock at CL=5 (ns)	70	
11	DIMM Configuration Type	00	
12	Refresh Rate/Type	82	
13	Primary DDR SDRAM Width	08	
14	Error Checking DDR2 SDRAM Device Width	00	
15	Reserved	01	
16	DDR SDRAM Device Attributes: Burst Length Supported	0E	
17	DDR SDRAM Device Attributes: Number of Device Banks	04	
18	DDR SDRAM Device Attributes: /CAS Latencies Supported	1C	
19	Reserved	01	
20	DDR SDRAM DIMM Type Information	02	
21	DDR SDRAM Module Attributes:	20	
22	DDR SDRAM Device Attributes: General	C0	
23	Minimum Clock Cycle at CL=4	60	

24	Maximum Data Access Time (t_{ac}) from Clock at CL=4 (ns)	70	
25	Minimum Clock Cycle Time at CL=3 (ns)	75	
26	Maximum Data Access Time (t_{ac}) from Clock at CL=3 (ns)	75	
27	Minimum Row Precharge Time (t_{RP}) (ns)	3C	
28	Minimum Row Active to Row Active delay (t_{RRD})	28	
29	Minimum RAS to CAS delay (t_{RCD}) (ns)	3C	
30	Minimum RAS Pulse Width (t_{RAS})	28	
31	Module Bank Density	80	
32	Address and Command Setup Time Before Clock (t_{IS}) (ns)	60	
33	Address and Command Hold Time After Clock (t_{IH}) (ns)	60	
34	Data Input Setup Time Before Clock (t_{DS})	40	
35	Data Input Hold Time After Clock (t_{DH}) (ns)	40	
36	Write Recovery Time (t_{WR})	00	
37	Internal Write to Read Command delay (t_{WTR})	00	
38	Internal Read to Precharge delay (t_{RTP})	00	
39	Memory Analysis Probe Characteristics	00	
40	Extension of Byte 41 t_{RC} and Byte 42 t_{RFC}	00	
41	Minimum Core Cycle Time (t_{RC}) (ns)	37	
42	Min. Auto Refresh Command Cycle Time (t_{RFC})	46	
43	Maximum Clock Cycle Time (t_{CK})	28	
44	Max. DQS-DQ Skew Factor (t_{DQS}) (ns)	28	
45	Read Data Hold Skew Factor (t_{QHS}) (ns)	50	
46	PLL Relock Time	00	
47	Tcasemax DT4R4W Delta	00	
48	Thermal Resistance of DRAM Package from Top (Case) to Ambient (Psi-T-A DRAM)	00	
49	DRAM Case Temperature Rise from Ambient due to Activate-Precharge/Mode Bits (DT0/Mode Bits)	00	
50	DRAM Case Temperature Rise from Ambient due to Precharge/Quiet Standby (DT2N/DT2Q)	00	

51	DRAM Case Temperature Rise from Ambient due to Precharge Power-Down (DT2P)	00	
52	DRAM Case Temperature Rise from Ambient due to Active Standby (DT3N)	00	
53	DRAM Case Temperature Rise from Ambient due to Active Power-Down with Fast PDN Exit (DT3Pfast)	00	
54	DRAM Case Temperature Rise from Ambient due to Active Power-Down with Slow PDN Exit (DT3Pslow)	00	
55	DRAM Case Temperature Rise from Ambient due to Page Open Burst Read/DT4R4W Mode Bit (DT4R/DT4R4W Mode Bit)	00	
56	DRAM Case Temperature Rise from Ambient due to Burst Refresh (ST5B)	00	
57	DRAM Case Temperature Rise from Ambient due to Bank interleave Reads with Auto-Precharge (DT7)	00	
58	Thermal Resistance of PLL Package from Top (Case) to Ambient (Psi T-A PLL)	00	
59	Thermal Resistance of Register Package from Top (Case) to Ambient (Psi T-A Register)	00	
60	PLL Case Temperature Rise from Ambient due to PLL Active (DT PLL Active)	00	
61	Register Case Temperature Rise from Ambient due to Register Active/Mode Bit (DT Register Active/Mode Bit)	00	
62	SPD Reversion	11	
63	Checksum for byte 0-62	B8	
64-71	Manufacture's JEDEC ID Code	InnoDisk	
72	Module Manufacturing Location	Manufacturing Code	
73-91	Module Part number	Module Part Number in ASCII	
92-255	Reserved	Undefined	

12. PACKAGE DIMENSION

- (512MB, 1 Rank 64Mx8 DDR SDRAMs)

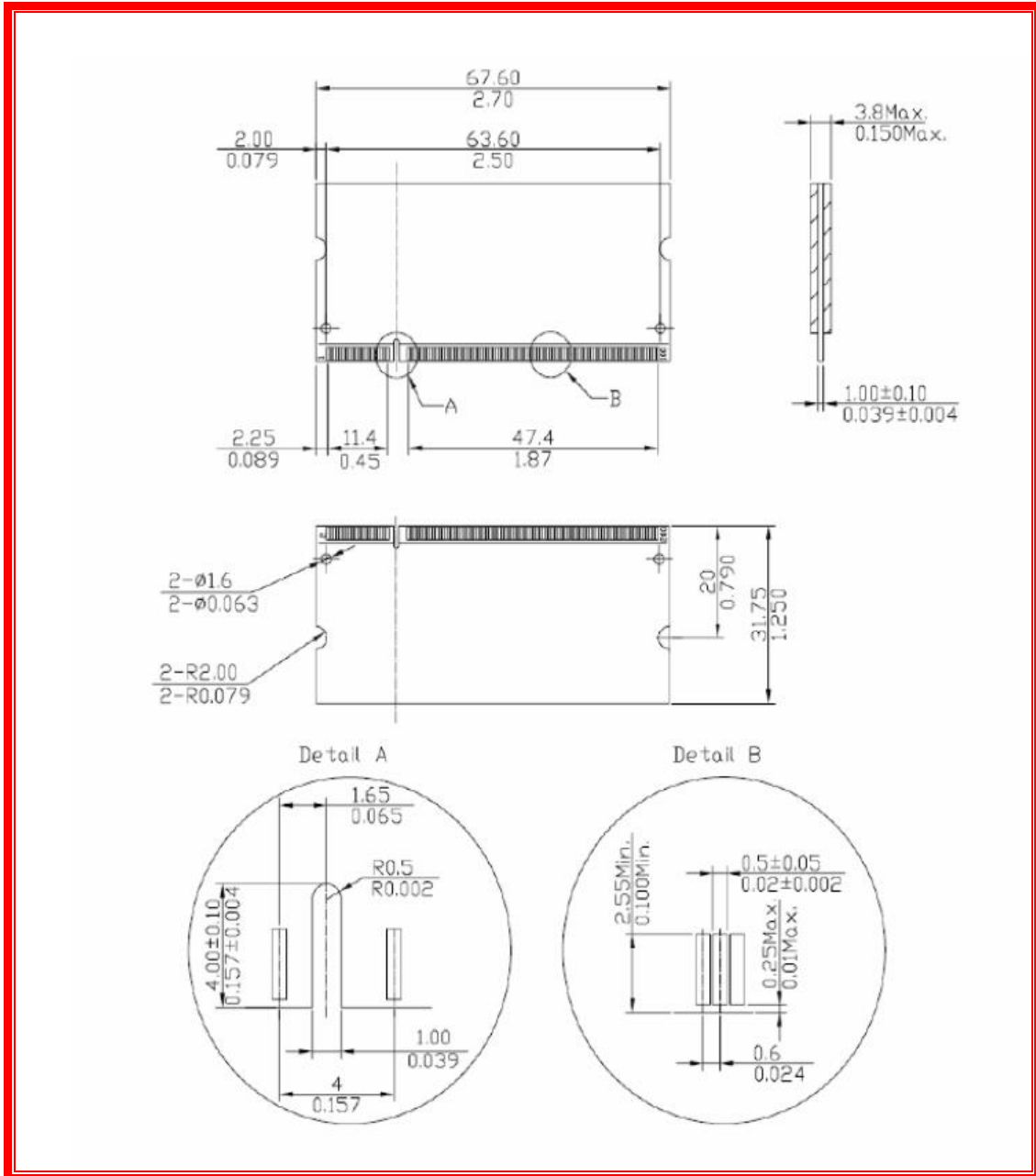

Note: Device position is only for reference.

13. RoHS Declaration



Declaration of Conformity

We, InnoDisk Co., Ltd, here declare the product M1SF-12MC4103/(X) complies with the requirement of RoHS directives 2011/65/EU and 2006/12/EC.

Innodisk ensures the above product meets RoHS requirements of six restricted substances. This declaration is based on vendor supplied analysis/MSDS, material certifications, and/ or 3rd party test reports of the component/ raw materials used in the manufacture of products.

✦ RoHS Exemptions Applied Of 7(C)-I for Resist.

Name of hazardous substance	Limited of RoHS ppm (mg/kg)
Cd	< 100 ppm
Pb	< 1000 ppm
Hg	< 1000 ppm
Chromium VI (Cr+6)	< 1000 ppm
Polybromodiphenyl ether (PBDE)	< 1000 ppm
Polybrominated Biphenyls (PBB)	< 1000 ppm

Date issued: 2014/11/26

Authorized Signature :

Manufacturer: : InnoDisk Co., Ltd.
 Address : 9F, No. 100, Sec.1 Xintai 5th Rd.,
Xizhi City, Taipei 221, Taiwan

QA Dept. Director - *Ryan Tsai*

2008©InnoDisk Corp. All rights reserved

InnoDisk Corp. reserves the right to change the Products and Specification without notices.

Revision Log

Rev	Date	Modification
0.1	12 th September 2014	Preliminary Edition
1.0	12 th September 2014	Official Released.
1.1	26 th November 2014	Updated RoHS declaration.