

HSDL-3003

IrDA[®] Data Compliant Low Power
115.2 kbit/s with Remote Control
Infrared Transceiver

LITEON[®]



Data Sheet

Description

The HSDL-3003 is a small form factor enhanced infrared (IR) transceiver module that provides the capability of (1) interface between logic and IR signals for through-air, serial, half-duplex IR data link, and (2) IR remote control transmission operating at the optimum 940 nm wavelength for universal remote control applications.

For IR data communication, the HSDL-3003 provides the flexibility of low power SIR applications and remote control applications with no external components needed for the selection of the type of application. The transceiver is compliant to IrDA[®] Physical Layer Specification Version 1.4 Low Power from 9.6 kbit/s to 115.2 kbit/s (SIR) and it is IEC 825-Class 1 Eye Safe.

The HSDL-3003 has very low idle current and can be shutdown completely to achieve very low power consumption. In the shutdown mode, the PIN diode will be inactive and thus producing very little photocurrent even under very bright ambient light. Such features are ideal for battery operated hand-held products such as PDAs and mobile phones.

General Features

- **Guaranteed temperature performance, -20° to 70° C**
 - Critical parameters are guaranteed over temperature and supply voltage
- **Low power consumption**
- **Small module size**
 - Height: 2.70 mm
 - Width: 8.00 mm
 - Depth: 2.95 mm

- **Minimum external components**
 - Integrated single-biased LED resistor
 - Direct interoperability to MPU
 - Programmable Txd features
 - Integrated remote control FET
- **Withstands >100 mV_{p-p} power supply ripple typically**
- **V_{CC} supply 2.4 to 3.6 volts**
- **Integrated EMI shield**
- **Designed to accommodate light loss with cosmetic windows**
- **IEC 825-Class 1 eye safe**
- **Lead-free and RoHS compliant**

Remote Control Features

- **Wide angle and high radiant intensity**
- **Spectrally suited to remote control transmission function at 940 nm typically**
- **Typical link distance up to 8 meters**

IrDA[®] Data Features

- **Fully compliant to IrDA[®] Physical Layer Specification 1.4 low power from 9.6 kbit/s to 115.2 kbit/s (SIR)**
 - Excellent nose-to-nose operation
 - Link distance up to 50 cm typically
- **Complete shutdown for TxD_IrDA, RxD_IrDA, and PIN diode**
- **Low power consumption**
 - Low idle current, 50 μ A typically
 - Low shutdown current, 10 nA typically
- **LED stuck-high protection**

Applications

- **Mobile data communication and universal remote control transmission**
 - Personal digital assistants (PDAs)
 - Mobile phones

CAUTION: The BiCMOS inherent to this design of this component increases the component's susceptibility to damage from Electrostatic Discharge (ESD). It is advised that normal static precautions be taken in handling and assembly of this component to prevent damage and/or degradation, which may be induced by ESD.

Order Information

Part Number	Packaging Type	Package	Quantity
HSDL-3003-021	Tape and Reel	Front View	2500
HSDL-3003-001	Tape and Reel	Front View	500

Marking Information

The unit is marked with a number '2' and 'YWWLL' on the shield for front option.

Y = year

WW = work week

LL = lot information

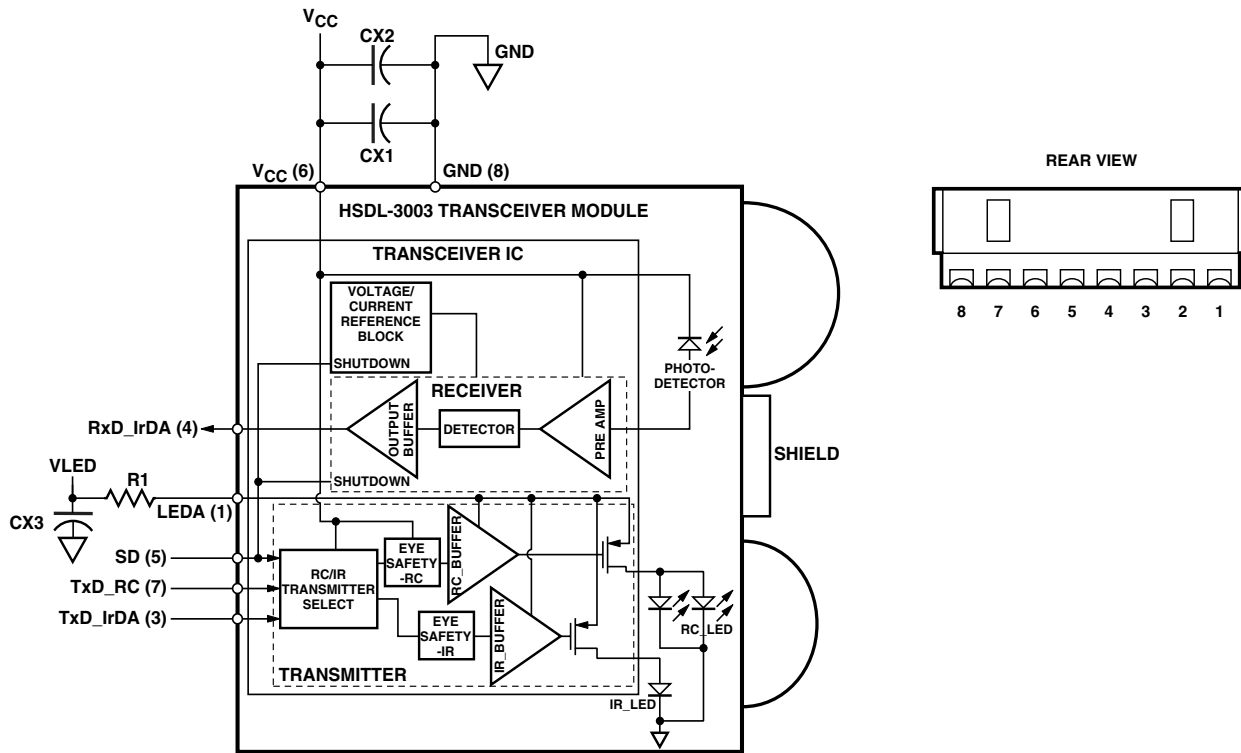

Figure 1. Functional block diagram of low power IrDA link distance and remote control.

I/O Pins Configuration Table

Pin	Symbol	I/O	Description	Notes
1	LEDA	I	IR and Remote Control LED Driver	Tied through external resistor, R1, to VLED from 2.4 to 4.5 Volt
2	N.C.	–	No Connection	No Connection
3	TxD_IrDA	I	IrDA Transmitter Data Input. Active High	Logic high turns on the IrDA LED. If held HIGH longer than ~50 μ s, the IrDA LED is turned off. TxD_IrDA must be driven either HIGH or LOW. Do not leave the pin floating
4	RxD_IrDA	O	IrDA Receiver Data Output. Active Low	Output is at LOW pulse response when light pulse is seen
5	SD	I	Shutdown. Active High	Complete shutdown TxD_IrDA, RxD_IrDA, and PIN diode. Do not leave the pin floating
6	V _{CC}	I	Supply Voltage	Regulated, 2.4 to 3.6 Volt
7	TxD_RC	I	Remote Control Transmission Input. Active High	Logic high turns on the RC LED. If held HIGH longer than ~50 μ s, the RC LED is turned off. TxD_RC must be driven either HIGH or LOW. Do not leave the pin floating
8	GND	I	Connect to System Ground	Tie this pin to system ground
–	Shield	–	EMI Shield	Tie to system ground via a low inductance trace. For best performance, do not tie it to the HSDL-3003 GND pin directly

Recommended Application Circuit Components

Component	Recommended Value
R1	1.8 Ω \pm 5%, 0.25 Watt for 2.4 \leq VLED \leq 2.7 V
	2.7 Ω \pm 5%, 0.25 Watt for 2.7 \leq VLED \leq 3.3 V
	3.3 Ω \pm 5%, 0.25 Watt for 3.0 \leq VLED \leq 3.6 V
	4.7 Ω \pm 5%, 0.25 Watt for 3.6 \leq VLED \leq 4.5 V
CX1 ^[1]	0.47 μ F \pm 20%, X7R Ceramic
CX2 ^[2]	6.8 μ F \pm 20%, Tantalum
CX3	6.8 μ F \pm 20%, Tantalum

Notes:

- CX1 must be placed within 0.7 cm of HSDL-3003 to obtain optimum noise immunity.
- The supply rejection performance can be enhanced by including CX2, as shown in Figure 1, in environment with noisy power supplies.

Different Remote Control Configurations for HSDL-3003

The HSDL-3003 can operate in the single-TXD programmable mode or the two-TXD direct transmission mode.

Single-TXD Programmable Mode

In the single-TXD programmable mode, only one input pin

(TxD_IrDA input pin) is used to turn on either the 875 nm LED or the 940 nm LEDs while the TxD_RC input pin is grounded.

The transceiver is in default mode (IrDA) when powered up. User needs to apply the following programming sequence to both the TxD_IrDA and SD inputs to enable the transceiver to operate in either the IrDA or remote control mode.

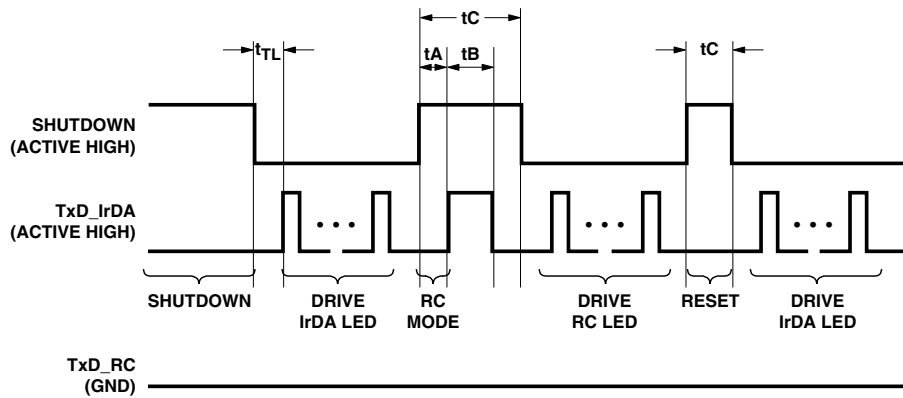

Figure 2.

Two-TXD Direct Transmission Mode

In the two-TXD direct transmission mode, the 875 nm LED and the 940 nm LEDs are turned on separately by two different input pins. The TxD_IrDA input pin is used to turn on the 875 nm LED while the TxD_RC input pin is used to turn on the 940 nm LEDs.

Please refer to the Transceiver I/O truth table for more details.

Transceiver Control I/O Truth Table for Two-TXD Direct Transmission Mode

SD	TXD_IrDA	TXD_RC	IrDA LED	RC LEDs	Remarks
0	0	0	OFF	OFF	IR Rx enabled. Idle mode
0	0	1	OFF	ON	Remote control operation
0	1	0	ON	OFF	IrDA Tx operation
0	1	1	DIM	ON	Not recommended
1	0	0	OFF	OFF	Shutdown mode*

* The shutdown condition will set the transceiver to the default mode (IrDA).

Absolute Maximum Ratings at $T_A = 25^\circ\text{C}$

For implementations where case to ambient thermal resistance is $\leq 50^\circ\text{C/W}$

Parameter	Symbol	Min.	Max.	Units	Conditions
Storage Temperature	T_S	-40	100	$^\circ\text{C}$	
Operating Temperature	T_A	-20	70	$^\circ\text{C}$	
LED Supply Voltage	V_{LED}	0	6	V	
Supply Voltage	V_{CC}	0	6	V	
Output Voltage: RxD	V_O	0	6	V	
Total LED Current Pulse Amplitude	I_{VLED}		580	mA	$\leq 90\ \mu\text{s}$ Pulse Width $\leq 20\%$ Duty Cycle
IR LED Current Pulse Amplitude	$(I_{VLED})_{IR}$		280	mA	$\leq 90\ \mu\text{s}$ Pulse Width $\leq 20\%$ Duty Cycle
RC LED Current Pulse Amplitude	$(I_{VLED})_{RC}$		580	mA	$\leq 90\ \mu\text{s}$ Pulse Width $\leq 20\%$ Duty Cycle

Recommended Operating Conditions

Parameter	Symbol	Min.	Max.	Units	Conditions
Operating Temperature	T_A	-20	70	$^\circ\text{C}$	
Supply Voltage	V_{CC}	2.4	3.6	V	
LED Supply Voltage	V_{LED}	2.4	4.5	V	
Logic Input Voltage	Logic High V_{IH}	$2/3 V_{CC}$	V_{CC}	V	
for TxD_IrDA, TxD_RC	Logic Low V_{IL}	0	$1/3 V_{CC}$	V	
Receiver Input Irradiance	Logic High E_{IH}	0.0081	500	mW/cm^2	For in-band signals $\leq 115.2\ \text{kbit/s}^{[3]}$
	Logic Low E_{IL}		0.3	$\mu\text{W}/\text{cm}^2$	For in-band signals ^[3]
Receiver Data Rate		9.6	115.2	kbit/s	

Electrical and Optical Specifications

Specifications (Min. and Max. values) hold over the recommended operating conditions unless otherwise noted. Unspecified test conditions may be anywhere in their operating range. All typical values (Typ.) are at 25°C with V_{CC} at 3.0 V unless otherwise noted.

Parameter	Symbol	Min.	Typ.	Max.	Units	Conditions
Infrared (IrDA) Receiver						
Viewing Angle	2θ _{1/2}	30			°	
Peak Sensitivity Wavelength	λ _P		875		nm	
RxD_IrDA Output Voltage	Logic High Logic Low	V _{OH} V _{OL}	V _{CC} - 0.2 0	V _{CC} 0.4	V V	I _{OH} = -200 μA, EI ≤ 0.3 μW/cm ²
RxD_IrDA Pulse Width (SIR) ^[4]	trpw	1	2.3	7.5	μs	θ _{1/2} ≤ 15°, C _L = 9 pF
RxD_IrDA Rise & Fall Times	tr, tf		30	100	ns	C _L = 9 pF
Receiver Latency Time ^[5]	t _L		26	50	μs	EI = 9.0 μW/cm ²
Receiver Wake Up Time ^[6]	trw		75	200	μs	EI = 10 mW/cm ²
Infrared (IrDA) Transmitter						
IR Radiant Intensity	I _{EH}	4	13		mW/sr	I _{VLEDA} = 100 mA, θ _{1/2} ≤ 15°, TxD_IrDA ≥ V _{IH} , T _A = 25°C
IR Viewing Angle	2θ _{1/2}	30		60	°	
IR Peak Wavelength	λ _P		875		nm	
TxD_IrDA Logic Levels	High Low	V _{IH} V _{IL}	2/3 V _{CC} 0	V _{CC} 1/3 V _{CC}	V V	
TxD_IrDA Input Current	High Low	I _H I _L	0.02 -0.02	1 1	μA μA	V _I ≥ V _{IH} 0 ≤ V _I ≤ V _{IL}
LED Current	Shutdown	I _{VLED}	0.02	10	μA	V _I (SD) ≥ V _{IH}
Wake Up Time ^[7]	t _{TW}		180	500	ns	
Data setup time	t _A	25			ns	
Data pulsewidth	t _B	25			ns	
Programming time	t _C	75			ns	
Optical Pulse Width (SIR)	t _{PW(SIR)}	1.41		1.6	μs	t _{PW(TXD)} = 1.6 μs at 115.2 kbit/s
Maximum Optical Pulse Width ^[8]	t _{PW(Max)}			120	μs	
TxD Rise & Fall Times (Optical)	tr, tf			600	ns	
LED Anode On-State Voltage	V _{ON (LEDA)}		2.4		V	I _{VLEDA} = 100 mA, V _I (TxD) ≥ V _{IH}
Remote Control (RC) Transmitter						
RC Radiant Intensity	I _{EH}	15 ^[9]	36		mW/sr	I _{VLEDA} = 400 mA, θ _{1/2} ≤ 15°, TxD_RC ≥ V _{IH} , T _A = 25°C
RC Viewing Angle	2θ _{1/2}	30		60	°	
RC Peak Wavelength	λ _P		940		nm	
TxD_RC Logic Levels	High Low	V _{IH} V _{IL}	2/3 V _{CC} 0	V _{CC} 1/3 V _{CC}	V V	
TxD_RC Input Current	High Low	I _H I _L	0.02 -0.02	1 1	μA μA	V _I ≥ V _{IH} 0 ≤ V _I ≤ V _{IL}
Maximum Optical Pulse Width ^[8]	t _{PW(Max)}			120	μs	
LEDA Voltage	V _{ON (LEDA)}		1.65	2.3	V	I _{VLEDA} = 400 mA, V _I (TxD) ≥ V _{IH}

Transceiver

Parameters		Symbol	Min.	Typ.	Max.	Units	Conditions
Input Current	High	I_H		0.01	1	μA	$V_I \geq V_{IH}$
	Low	I_L	-1	-0.02	1	μA	$0 \leq V_I \leq V_{IL}$
Supply Current	Shutdown	I_{CC1}		0.01	1	μA	$V_{SD} \geq V_{CC} - 0.5, T_A = 25^\circ\text{C}$
	Idle (Standby)	I_{CC2}		50	100	μA	$V_{I(TxD)} \leq V_{IL}, EI = 0$
	Active	I_{CC3}		300		μA	$V_{I(TxD)} \geq V_{IL}, EI = 10 \text{ mW/cm}^2$

Notes:

- An in-band optical signal is a pulse/sequence where the peak wavelength, λ_P , is defined as $850 \text{ nm} \leq \lambda_P \leq 900 \text{ nm}$, and the pulse characteristics are compliant with the IrDA Serial Infrared Physical Layer Link Specification version 1.4.
- For in-band signals 9.6 kbit/s to 115.2 kbit/s where $9 \mu\text{W/cm}^2 \leq EI \leq 500 \text{ mW/cm}^2$.
- Latency is defined as the time from the last TxD_IrDA light output pulse until the receiver has recovered full sensitivity.
- Receiver Wake Up Time is measured from V_{CC} power ON to valid RxD_IrDA output.
- Transmitter Wake Up Time is measured from V_{CC} power ON to valid light output in response to a TxD_IrDA pulse.
- The Optical PW is defined as the maximum time which the IrDA/RC LED will turn on, this is to prevent the long Turn On time for the IrDA and RC LED.
- This Limits is Production Test Limits.

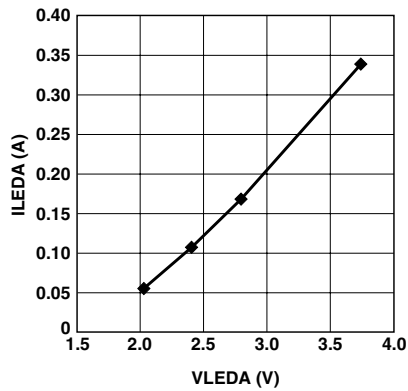

Figure 3. Typical 875 nm LED VLEDA vs. ILEDA at room temperature.

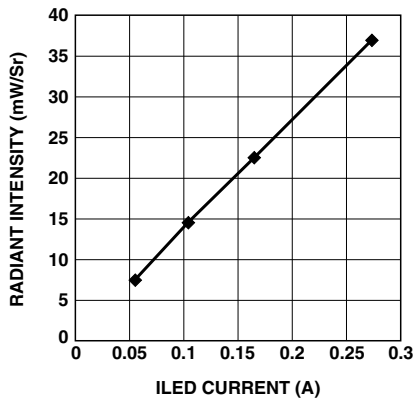

Figure 4. Typical 875 nm LED radiant intensity vs. ILED current at room temperature.

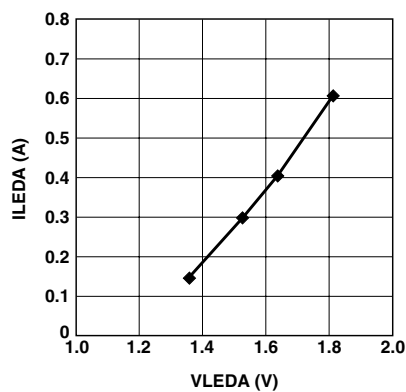

Figure 5. Typical 940 nm LED VLEDA vs. ILEDA at room temperature performance.

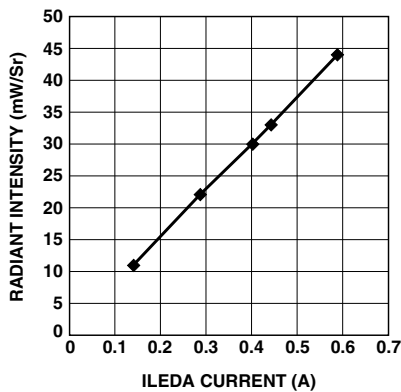

Figure 6. Typical 940 nm LED radiant intensity vs. ILED current at room temperature.

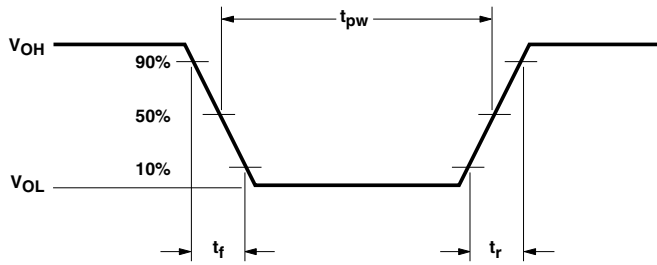

Figure 7. RXD output waveform.

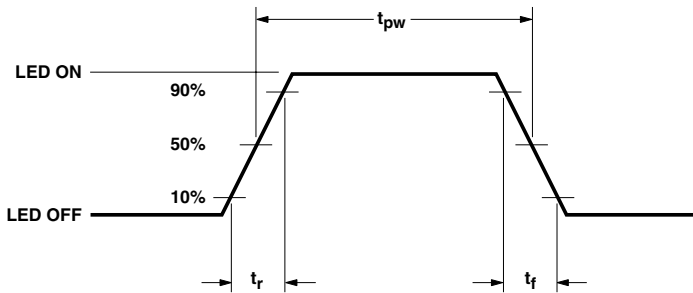

Figure 8. LED optical waveform.

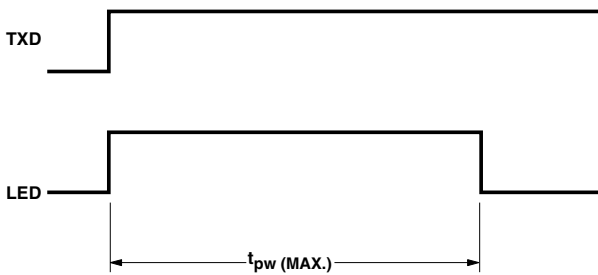

Figure 9. TXD "Stuck ON" protection.

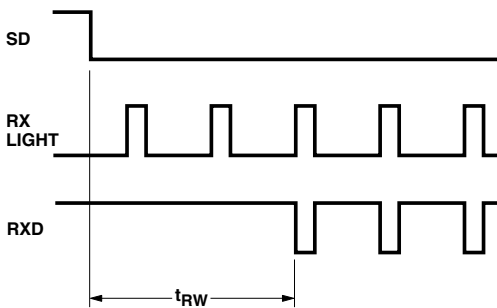

Figure 10. Receiver wakeup time definition.

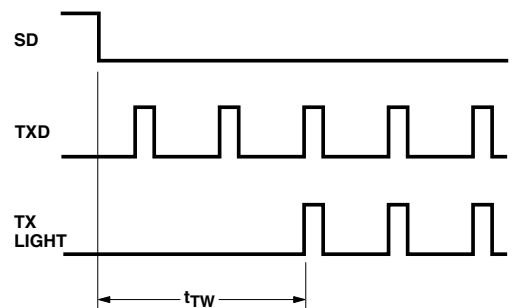

Figure 11. Transmitter wakeup time definition.

HSDL-3003 Package Outline (With Integrated EMI Shield)

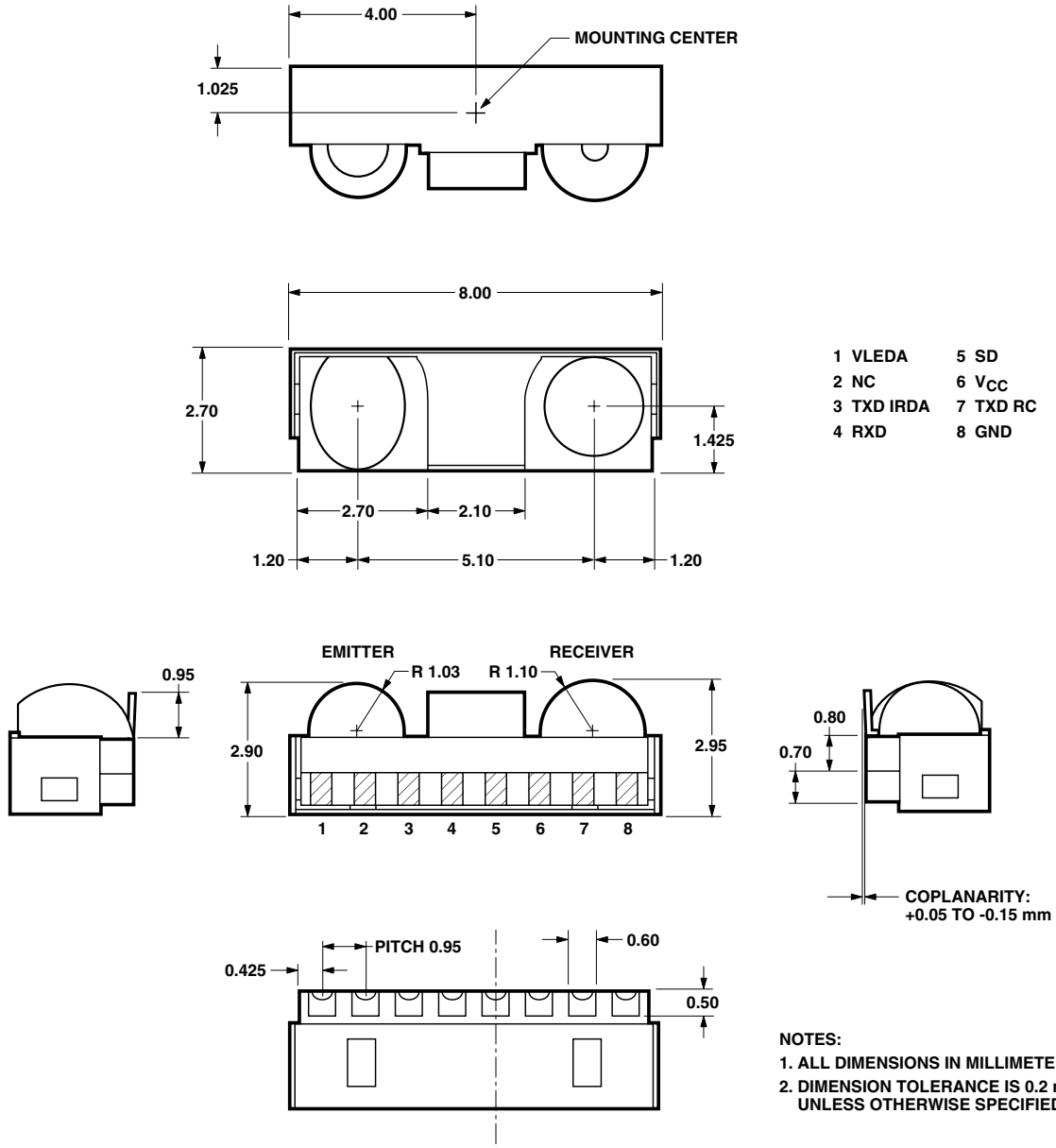

Figure 12. Package outline drawing.

HSDL-3003 Tape and Reel Dimensions

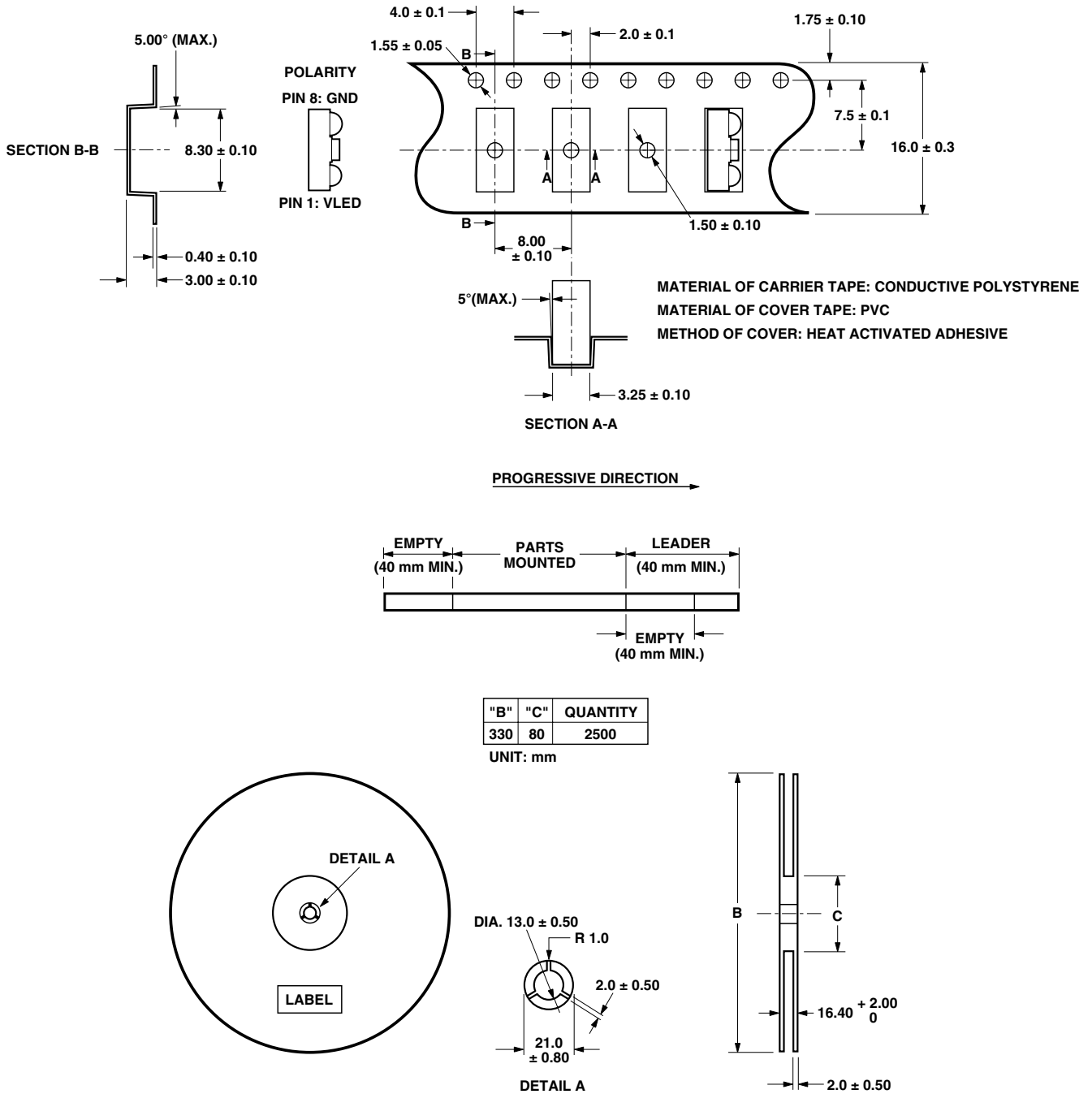

Figure 13. Tape and reel dimensions.

Moisture Proof Packaging

All HSDL-3003 options are shipped in moisture proof package. Once opened, moisture absorption begins.

This part is compliant to JEDEC Level 4.

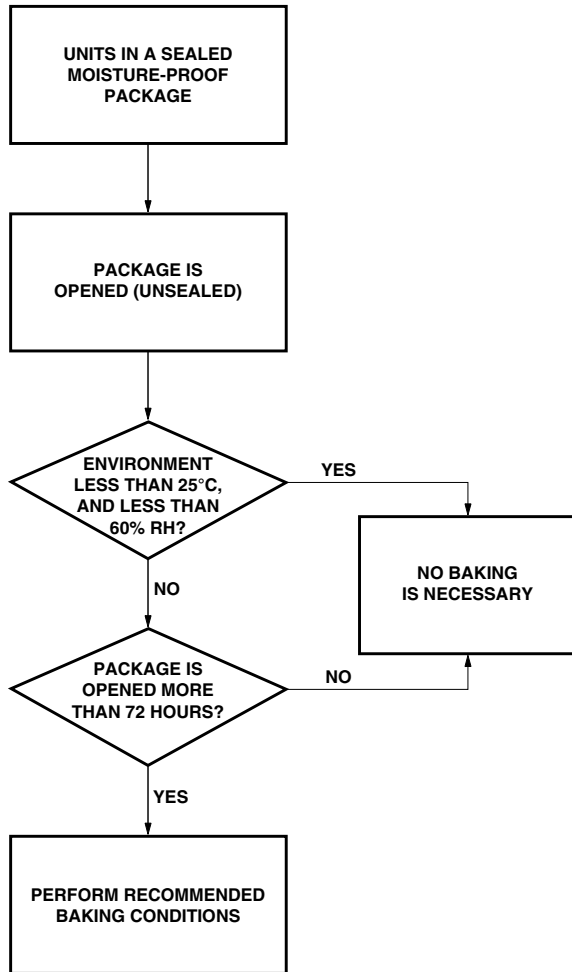

Figure 15. Baking conditions chart.

Baking Conditions

If the parts are not stored in dry conditions, they must be baked before reflow to prevent damage to the parts.

Package	Temp.	Time
In reels	60°C	≥ 48 hours
In bulk	100°C	≥ 4 hours
	125°C	≥ 2 hours
	150°C	≥ 1 hour

Baking should only be done once.

Recommended Storage Conditions

Storage Temperature	10°C to 30°C
Relative Humidity	below 60% RH

Time from Unsealing to Soldering

After removal from the bag, the parts should be soldered within two days if stored at the recommended storage conditions. If times longer than 72 hours are needed, the parts must be stored in a dry box.

Recommended Reflow Profile

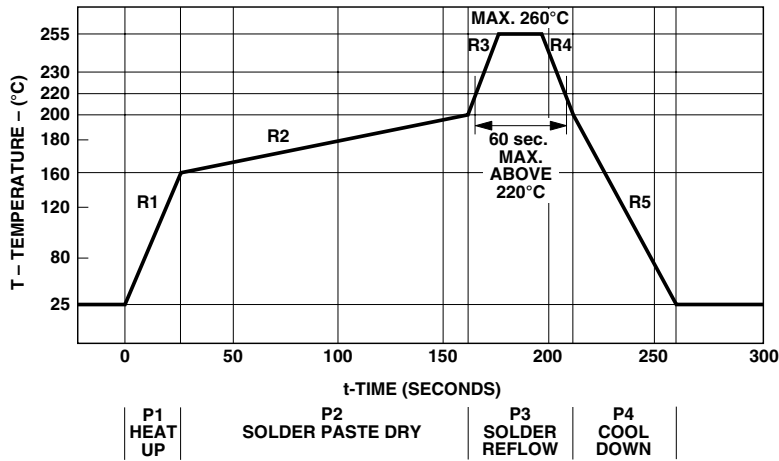

Figure 16. Reflow graph.

Process	Symbol	ΔT	Maximum $\Delta T/\Delta time$
Heat Up	P1, R1	25°C to 160°C	4°C/s
Solder Paste Dry	P2, R2	160°C to 200°C	0.5°C/s
Solder Reflow	P3, R3	200°C to 255°C (260°C at 10 seconds max.)	4°C/s
	P3, R4	255°C to 200°C	-6°C/s
Cool Down	P4, R5	200°C to 25°C	-6°C/s

The reflow profile is a straight-line representation of a nominal temperature profile for a convective reflow solder process. The temperature profile is divided into four process zones, each with different $\Delta T/\Delta time$ temperature change rates. The $\Delta T/\Delta time$ rates detailed in the above table. The temperatures are measured at the component to printed circuit board connections.

In **process zone P1**, the PC board and I/O pins are heated to a temperature of 160°C to activate the flux in the solder paste. The temperature ramp up rate, R1, is limited to 4°C per second to allow for even heating of both the PC board and HSDL-3003 I/O pins.

Process zone P2 should be of sufficient time duration (60 to -120 seconds) to dry the solder paste. The temperature is raised to a level just below the liquidus point of the solder, usually 200°C (392°F).

Process zone P3 is the solder reflow zone. In zone P3, the temperature is quickly raised above the liquidus point of solder to 255°C (491°F) for optimum results. The dwell time above the liquidus point of solder should be between 20 and 60 seconds. It usually takes about 20 seconds to assure proper coalescence of the solder balls into liquid solder and the formation of good solder connections. Beyond a dwell time of 60 seconds, the intermetallic

growth within the solder connections becomes excessive, resulting in the formation of weak and unreliable connections. The temperature is then rapidly reduced to a point below the solidus temperature of the solder, usually 200°C (392°F), to allow the solder within the connections to freeze solid.

Process zone P4 is the cool down after solder freeze. The cool down rate, R5, from the liquidus point of the solder to 25°C (77°F) should not exceed -6°C per second maximum. This limitation is necessary to allow the PC board and transceiver's castellation I/O pins to change dimensions evenly, putting minimal stresses on the HSDL-3003.

Appendix A: SMT Assembly Application Note

1.0 Solder Pad, Mask and Metal Stencil

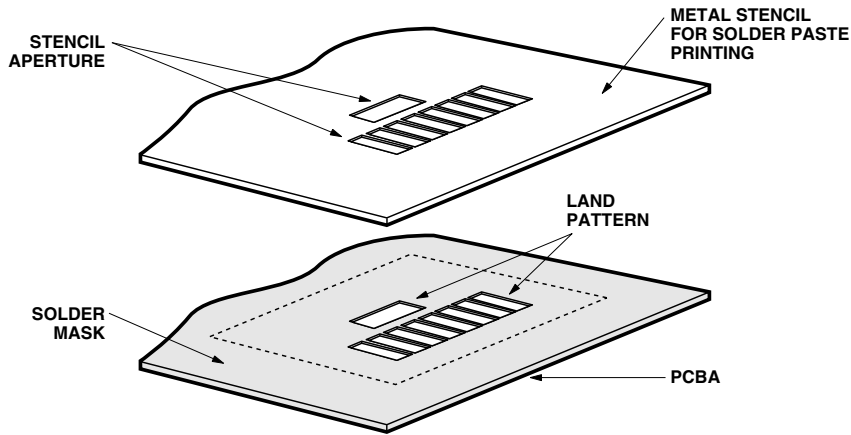

Figure 17. Stencil and PCBA.

1.1 Recommended Land Pattern

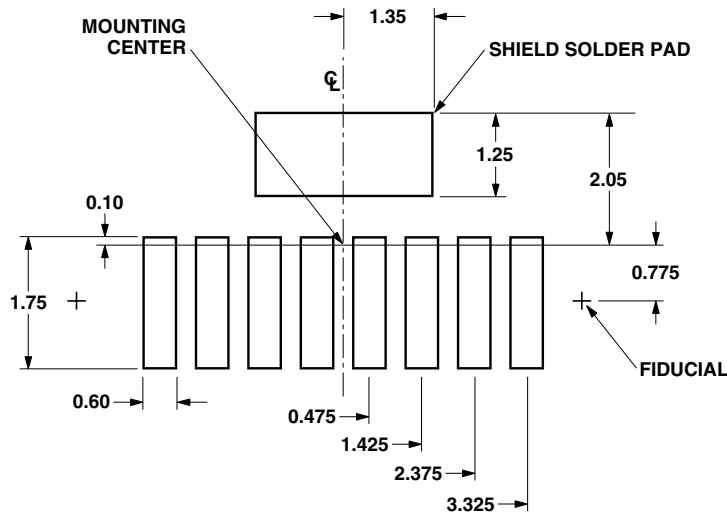

Figure 18. Land pattern (front view).

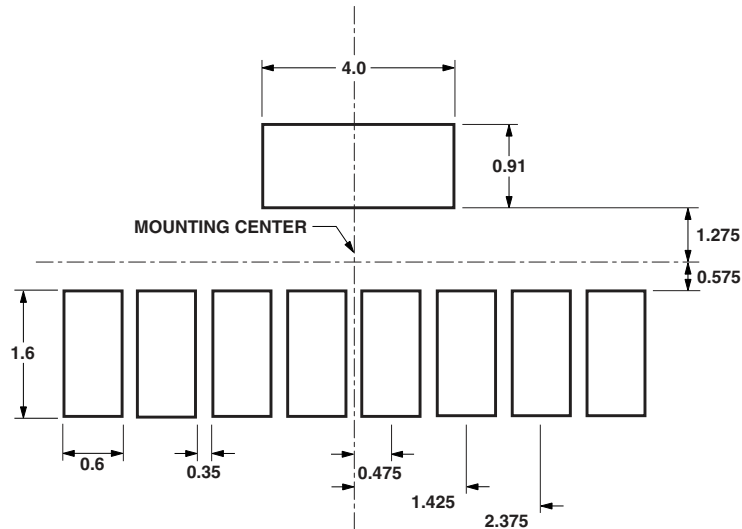

Figure 19. Land pattern (top view).

1.2 Recommended Metal Solder Stencil Aperture

It is recommended that only a 0.152 mm (0.006 inch) or a 0.127 mm (0.005 inch) thick stencil be used for solder paste printing. This is to ensure adequate printed solder paste volume and no shorting. See the table below the drawing for combinations of metal stencil aperture and metal stencil thickness that should be used.

Aperture opening for shield pad is 3.05 mm x 1.1 mm as per land pattern.

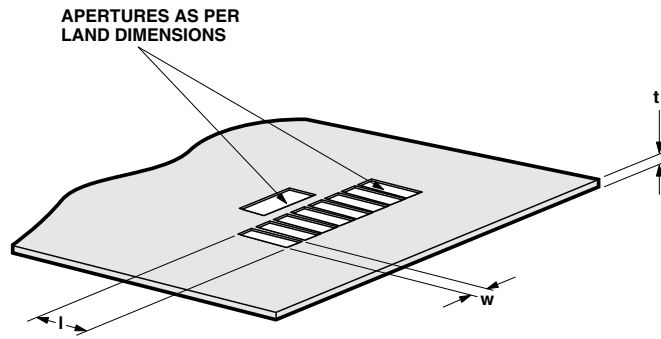

Figure 20. Solder stencil aperture.

Stencil thickness, t (mm)	Aperture size(mm)	
	length, l	width, w
0.152 mm	2.60 ± 0.05	0.55 ± 0.05
0.127 mm	3.00 ± 0.05	0.55 ± 0.05

1.3 Adjacent Land Keepout and Solder Mask Areas

Adjacent land keepout is the **maximum space** occupied by the unit relative to the land pattern. There should be no other SMD components within this area.

The minimum solder resist strip width required to avoid solder bridging adjacent pads is **0.2 mm**.

It is recommended that two fiducial crosses be placed at mid-length of the pads for unit alignment.

Note: Wet/Liquid Photo-Imageable solder resist/mask is recommended.

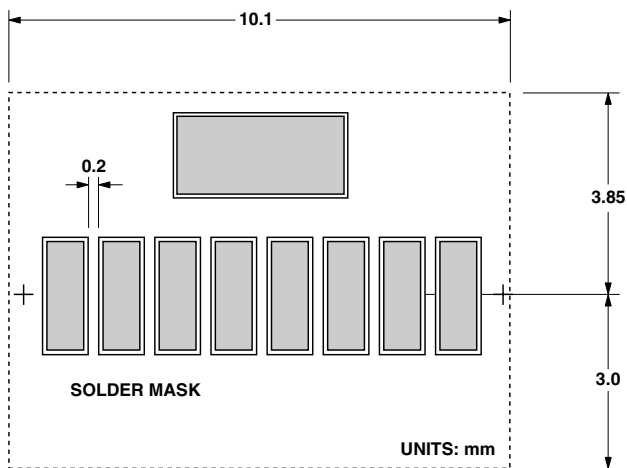

Figure 21. Adjacent land keepout and solder mask areas.

Appendix B: PCB Layout Suggestion

The following PCB layout guidelines should be followed to obtain a good PSRR and EM immunity resulting in good electrical performance. Things to note:

1. The ground plane should be continuous under the part, but should not extend under the shield trace.
2. The shield trace is a wide, low inductance trace back to the system ground. CX1, CX2 and

CX3 are optional supply filter capacitors; they may be left out if a clean power supply is used.

3. VLED can be connected to either unfiltered or unregulated power supply. If VLED and Vcc share the same power supply, CX3 need not be used and the connections for CX1 and CX2 should be before the current limiting resistor R1. In a noisy environment, including capacitor CX2 can enhance supply rejection. CX1 is generally a ceramic capacitor of low inductance providing a wide frequency response while

CX2 and CX3 are tantalum capacitors of big volume and fast frequency response. The use of a tantalum capacitor is more critical on the VLED line, which carries a high current.

4. Preferably a multi-layered board should be used to provide sufficient ground plane. Use the layer underneath and near the transceiver module as Vcc, and sandwich that layer between ground connected board layers. Refer to the diagram below for an example of a four-layer board.

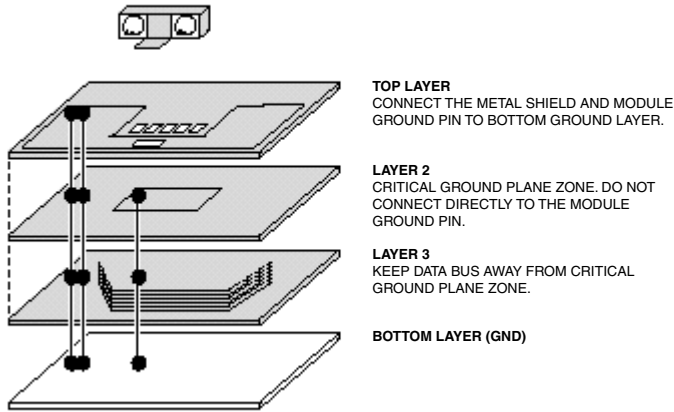

The area underneath the module at the second layer, and 3 cm in all directions around the module, is defined as the critical ground plane zone. The ground plane should be maximized in this zone.

Refer to application note AN1114 or the Lite-On IrDA Data Link Design Guide for details. The layout below is based on a two-layer PCB.

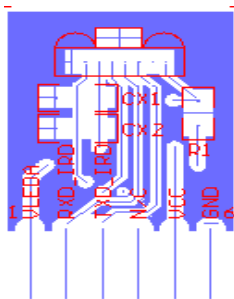

Top View

Bottom View

**Appendix C:
General Application Guide for
the HSDL-3003 Infrared IrDA®
Compliant 115.2 Kb/s
Transceiver**

Description

The HSDL-3003, a wide-voltage operating range infrared transceiver is a low-cost and small form factor device that is designed to address the mobile computing market such as PDAs, as well as small embedded mobile products such as digital cameras and cellular phones. It is spectrally suited to universal remote control transmission function at 940 nm typically. It is fully compliant to IrDA 1.4 low power specification

from 9.6 kb/s to 115.2 kb/s, and supports most remote control codes. The design of the HSDL-3003 also includes the following unique features:

- Spectrally suited to universal remote control transmission function at 940 nm typically.
- Low passive component count.
- Shutdown mode for low power consumption requirement.

Selection of Resistor R1

Resistor R1 should be selected to provide the appropriate peak pulse LED current over different ranges of Vcc as shown on page 3 under "Recommended Application Circuit Components".

Interface to Recommended I/O Chips

The HSDL-3003's TXD data input is buffered to allow for CMOS drive levels. No peaking circuit or capacitor is required. Data rate from 9.6 kb/s up to 115.2 kb/s is available at the RXD pin. The TXD_RC, (pin 7), or the TXD_IrDA, (pin 3), can be used to send remote control codes.

The block diagrams below show how the IrDA port fits into a mobile phone and PDA platform.

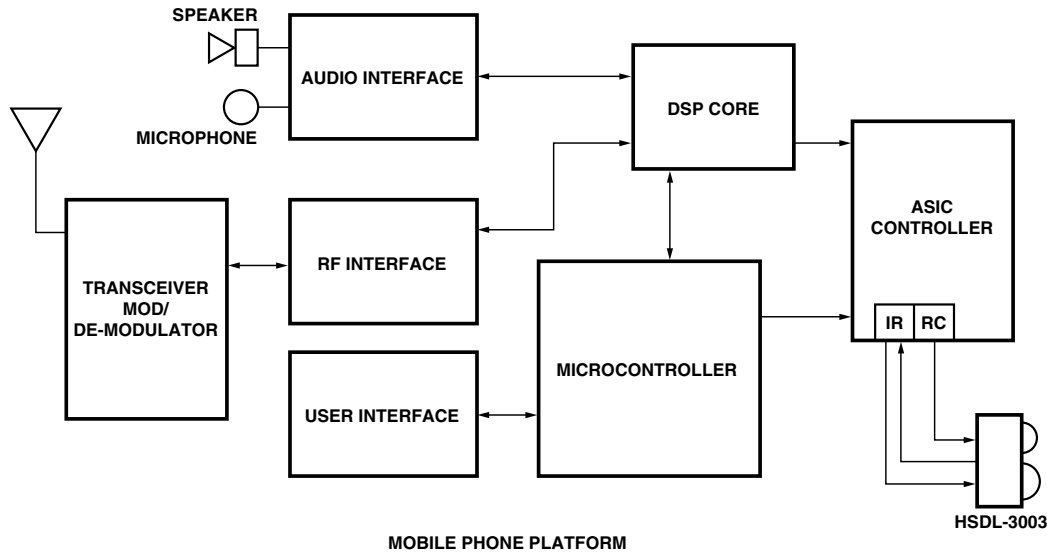

Figure 1. IR layout in mobile phone platform.

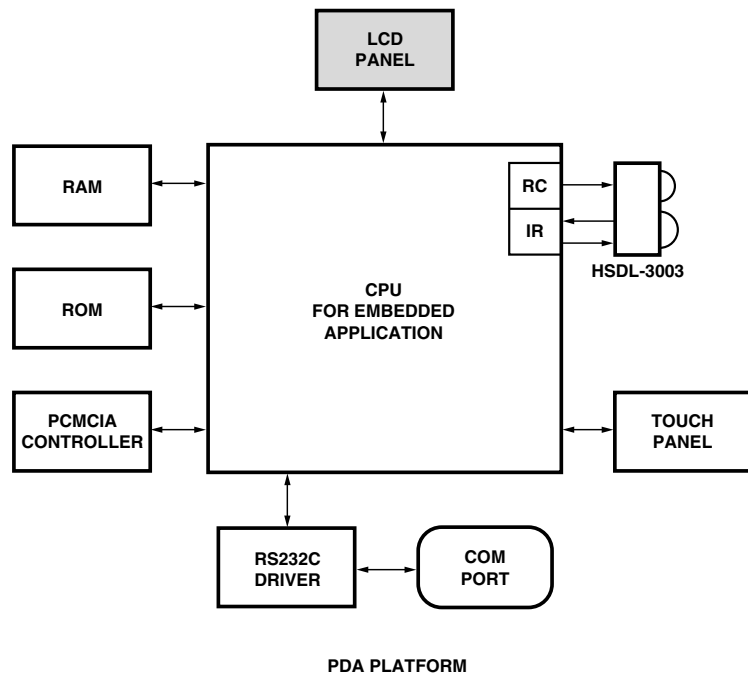

Figure 2. IR layout in PDA platform.

The link distance testing was done using typical HSDL-3003 units with SMC's FDC37C669 and FDC37N769 Super I/O controllers. An IrDA link distance of up to 70 cm was demonstrated.

Remote Control Operation

The HSDL-3003 is spectrally suited to universal remote control transmission function at 940 nm typically. Remote control applications are not governed by any standards, owing to which there are numerous remote control codes in the market. Each of these standards results in receiver modules with different sensitivities, depending on the carrier frequencies and responsivity to the incident light wavelength.

Based on a survey of some commonly used remote control receiver modules, the irradiance is found to be in the range of 0.05 ~ 0.07 mW/cm². Based on a typical irradiance of 0.05 mW/cm² and 0.075 mW/cm² and turning on the RC LED, a typical link distance of 8 m and 7 m is achieved typically.

**Appendix D:
Window Designs for
HSDL-3003**

To ensure IrDA compliance, some constraints on the height and width of the window exist. The minimum dimensions ensure that the IrDA

cone angles are met without vignetting. The maximum dimensions minimize the effects of stray light. The minimum size corresponds to a cone angle of 30° and the maximum size corresponds to a cone angle of 60°.

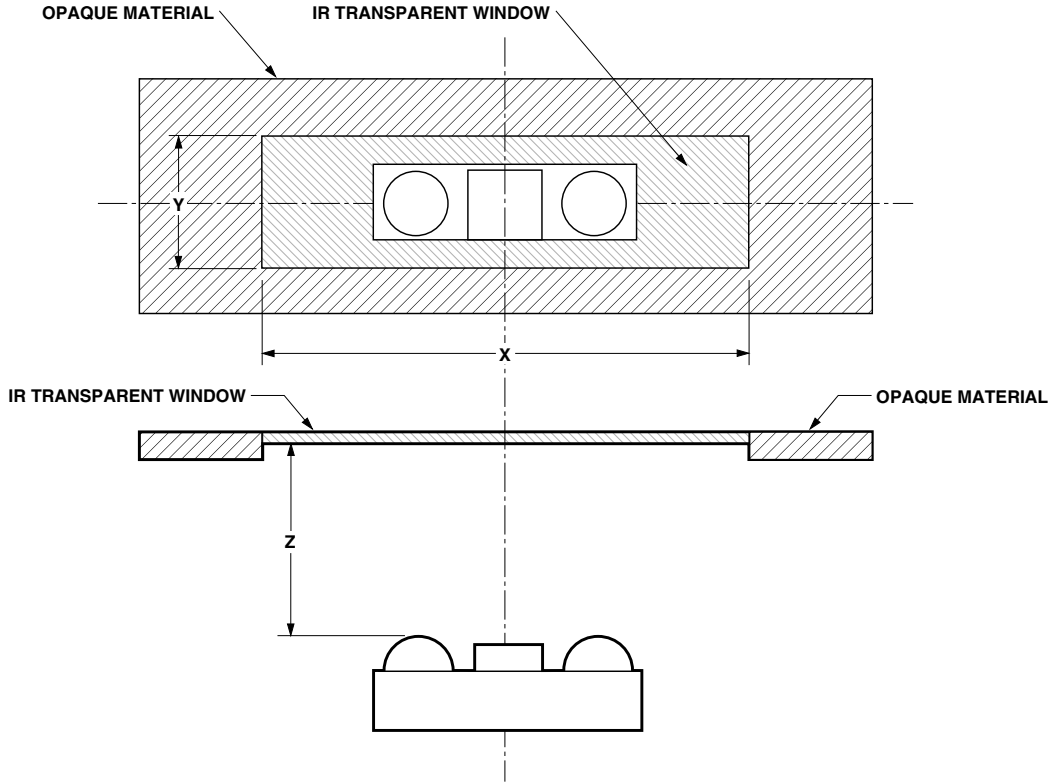

In the figure above, X is the width of the window, Y is the height of the window, and Z is the distance from the HSDL-3003 to the back

of the window. Our simulations result in the following tables and graphs.

Module Depth (Z, mm)	Min Aperture Width (X, mm)	Min Aperture Height (Y, mm)
0.5	11.45	4.20
1.0	11.75	4.45
1.5	12.00	5.00
2.0	12.50	5.25
3.0	13.50	6.30
4.0	15.15	8.40
5.0	15.65	9.45

Aperture width (X) vs. module depth.

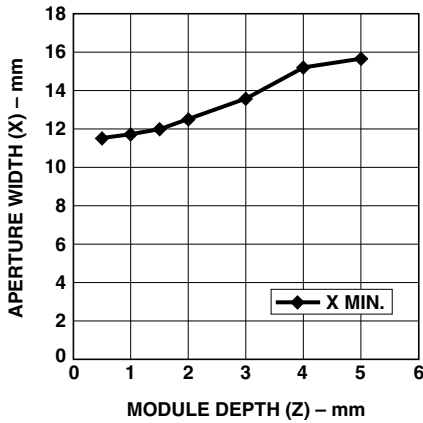

Aperture height (Y) vs. module depth.

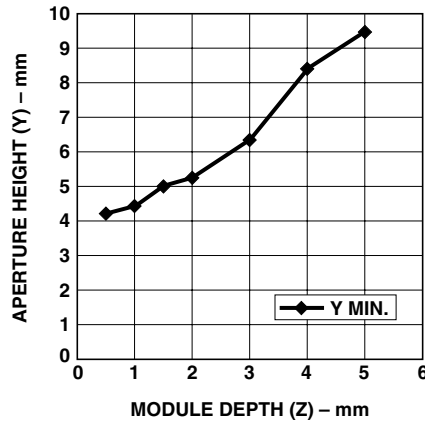

For module depth values that are not shown on the table above, the minimum X and Y values can be interpolated. An example of this interpolation for module depth of 0.8 mm is as follows:

$$X_{\min} = \frac{0.8 - 0.5}{1.0 - 0.5} \times (11.75 - 11.45) + 11.45 = 11.63$$

$$Y_{\min} = \frac{0.8 - 0.5}{1.0 - 0.5} \times (4.45 - 4.20) + 4.20 = 4.35$$

Window Material

Almost any plastic material will work as a window material. Polycarbonate is recommended. The surface finish of the plastic should be smooth, without any texture. An IR filter dye may be used in the window to make it look black to the eye, but the

total optical loss of the window should be 10% or less for best optical performance. Light loss should be measured at 875 nm.

The recommended plastic materials for use as a cosmetic window are available from General Electric Plastics.

Recommended Plastic Materials

Material #	Light Transmission	Haze	Refractive Index
Lexan 141	88%	1%	1.586
Lexan 920A	85%	1%	1.586
Lexan 940A	85%	1%	1.586

Note: 920A and 940A are more flame retardant than 141.

Recommended Dye: Violet #21051 (IR transmittant above 625 nm)

Shape of the Window

From an optics standpoint, the window should be flat. This ensures that the window will not alter either the radiation pattern of the LED, or the receive pattern of the photodiode.

If the window must be curved for mechanical or industrial design reasons, place the same curve on the back side of the window that has an identical radius as the front side. While this will not completely eliminate the lens effect of the front curved surface, it will significantly reduce the effects. The amount of change in

the radiation pattern is dependent upon the material chosen for the window, the radius of the front and back curves, and the distance from the back surface to the transceiver. Once these items are known, a lens design can be made which will eliminate the effect of the front surface curve.

The following drawings show the effects of a curved window on the radiation pattern. In all cases, the center thickness of the window is 1.5 mm, the window is made of polycarbonate plastic, and the distance from the transceiver to the back surface of the window is 3 mm.

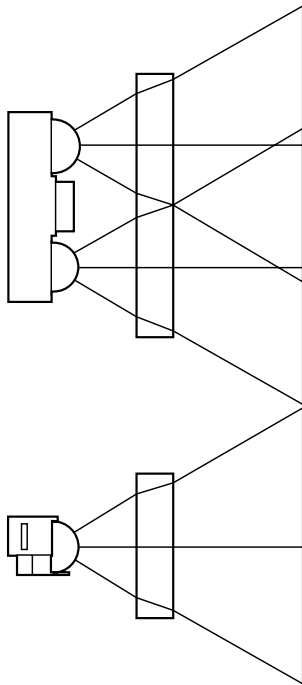

Flat Window
(First choice)

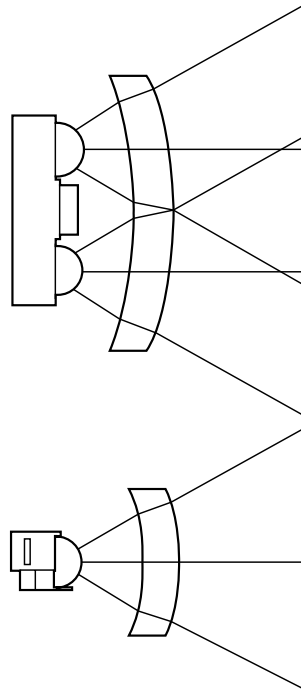

Curved Front and Back
(Second choice)

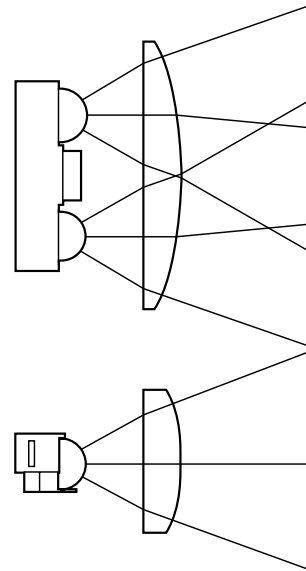

Curved Front, Flat Back
(Do not use)

For company and product information, please go to our web site: WWW.liteon.com or
<http://optodatabook.liteon.com/databook/databook.aspx>

Data subject to change. Copyright © 2007 Lite-On Technology Corporation. All rights reserved.

