



# CMOS Circuit for Analog Quartz Clocks with Bipolar Stepping Motor Drive

## Description

The H1344 is a low power 32kHz analog clock integrated circuit designed in CMOS technology to drive a bipolar stepping motor. A set of capacitors is provided on chip to be connected, in any combination, to the two oscillator terminals, with a maximum total capacitance of 48pF. Both the motor pulse period and the motor pulse width are mask-programmable (see page 6 for already available options). For versions v143 and v221, the TEST1 and TEST2 pins are only for test and must not be used in the application.

## Applications

- Stepper Motor Driver for time-switches
- Analog clocks

## Features

- 32kHz quartz oscillator
- Integrated capacitors, mask selectable
- Single battery operation
- 0.7  $\mu$ A typical current consumption
- Low resistance outputs for bipolar stepping motor
- Mask options for pad designation, motor period and pulse width, alarm frequency, modulation and duty cycle
- Alarm output function compatible with either NPN or PNP-driver transistors
- Alarm input function
- 1024Hz output on AL<sub>IN</sub> pad for oscillator frequency verification
- Fast test function
- ESD protected terminals

## Functional Diagram

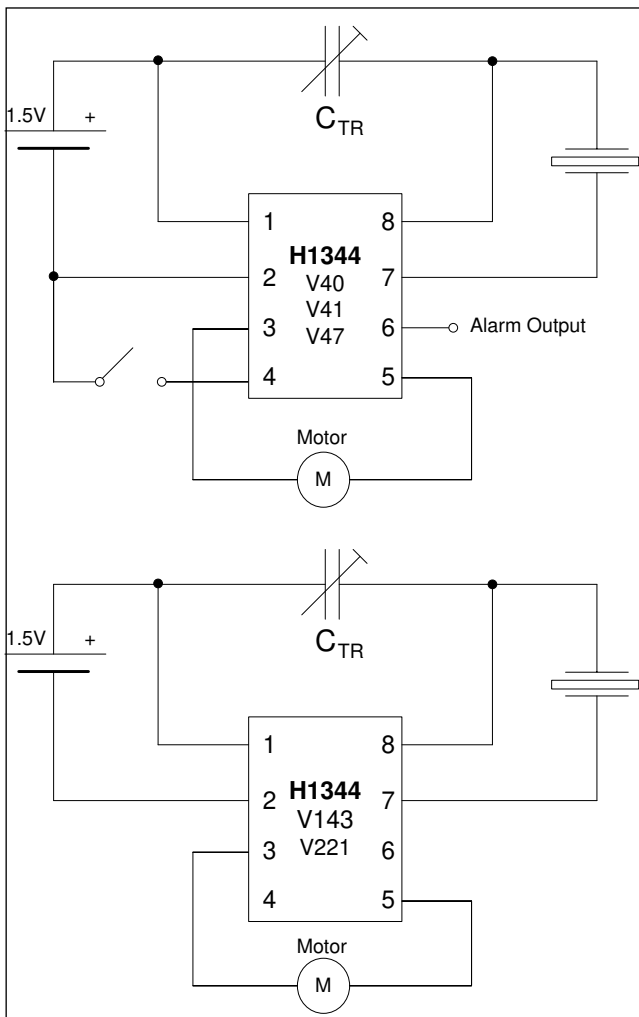

Fig. 1

## Pin Assignment

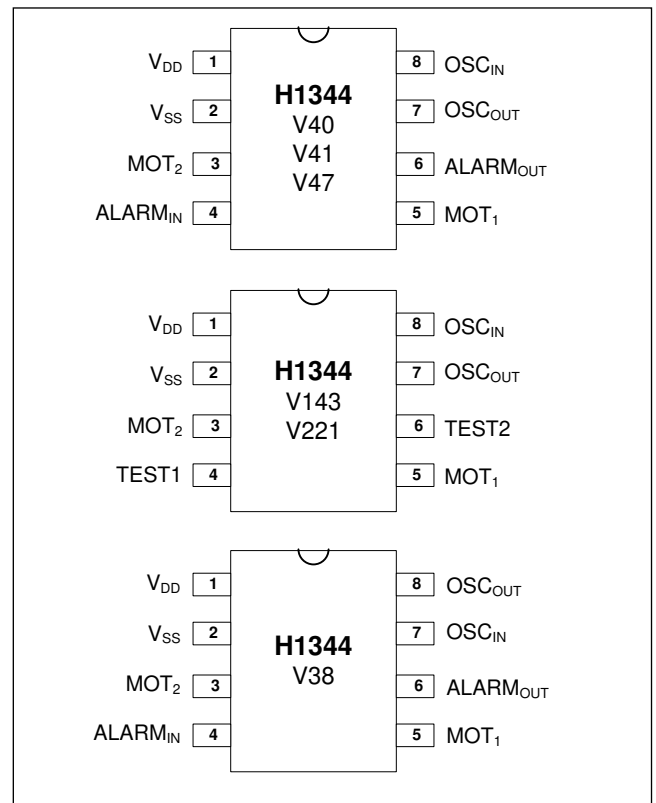

Fig. 2



## Absolute Maximum Ratings

Parameter	Symbol	Min.	Max.	Units
Supply voltage range	$V_{DD} - V_{SS}$	-0.3	+5	V
Input voltage	$V_{IN}$	$V_{SS}$	$V_{DD}$	V
Storage temperature	$T_{STOR}$	-55	+125	°C

Table 1

Stresses beyond these listed maximum ratings may cause permanent damage to the device. Exposure to conditions beyond specified operating conditions may affect device reliability or cause malfunction.

## Handling Procedures

This device contains circuitry to protect the terminals against damage due to high static voltages or electrical fields. However, it is advised that normal precautions be taken to avoid application of any voltage higher than maximum rated voltages to this circuit.

## Recommended Operating Conditions

Parameter	Symbol	Value	Units
Ambient temperature	T	25	°C
Quartz frequency	$F_Q$	32768	Hz
Quartz series resistance	$R_Q$	30	k $\Omega$
Motor coil resistance	$R_M$	200	$\Omega$
Positive supply	$V_{DD}$	1.55	V
Negative supply	$V_{SS}$	0	V

Table 2

## Operating Conditions

Parameter	Symbol	Min.	Typ.	Max.	Units
Operating temperature	$T_{OPR}$	-20		+70	°C
Quartz series resistance			30	50	k $\Omega$
Trimmer capacitance	$C_{TR}$	1.5		30	pF

Table 3

## Electrical and Switching Characteristics

at recommended operating conditions (valid unless otherwise specified)

Parameter	Symbol	Test	Min.	Typ.	Max.	Units
Supply voltage	$V_{DD}$	operating	+1.1		+1.8	V
Supply current	$I_{DD}$	without motor, $AL_{IN}$ open		0.7	2.0	$\mu A$
<b>Motor Output</b>						
Current into load	$I_M$	$V_{DD} = 1.2V, R_M = 200\Omega$	$\pm 4.0$			mA
Pulse period	$T_1$			Mask option*		s
Pulse width	$t_w$			Mask option*		ms
<b>Alarm Output</b>						
Frequency	$f_A$			Mask option*		Hz
Modulation	$f_{A1}$			Mask option*		Hz
Cycle time	$T_2$			Mask option*		s
Pulse duration	$t_P$			Mask option*		s
Output current for driving NPN-transistor	$I_{ALOUTN}$	$V_{DD} = 1.2V, V_{OL} = 0.2V$	0.5			$\mu A$
Output current for driving PNP-transistor	$I_{ALOUTN}$	$V_{DD} = 1.2V, V_{OH} = 0.7V$	0.3			mA
Output current for driving PNP-transistor	$I_{ALOUTN}$	$V_{DD} = 1.2V, V_{OL} = 0.5V$	0.3			mA
Output current for driving PNP-transistor	$I_{ALOUTN}$	$V_{DD} = 1.2V, V_{OH} = 1.0V$	0.5			$\mu A$
<b>Alarm Input</b>						
<b>Test In/Output</b>						
Alarm input delay	$t_{ALD}$		125		570	ms
Test frequency	$f_T$			1024		Hz
Input current (alarm)	$I_{IN}$	Input at $V_{SS}, V_{DD} = 1.4V$	-1	-5	-10	$\mu A$
Input current	$I_{IN}$	Input at $V_{DD}$	1	15	30	$\mu A$
<b>Oscillator</b>						
Build-up time	$t_{START}$	$V_{DD} = 1.2V$			2	s
Stability against supply voltage variation	$\frac{\Delta f}{\Delta V_{DD} \times f}$	$1.1V \leq V_{DD} \leq 1.8V$		5	12	ppm/V
Output capacitance	$C_{OUT}$			Mask option*		pF
Input capacitance	$C_{IN}$			Mask option*		pF

Table 4

\* See "Available options" on page 6.

Timing Waveforms

Motor Output Waveform

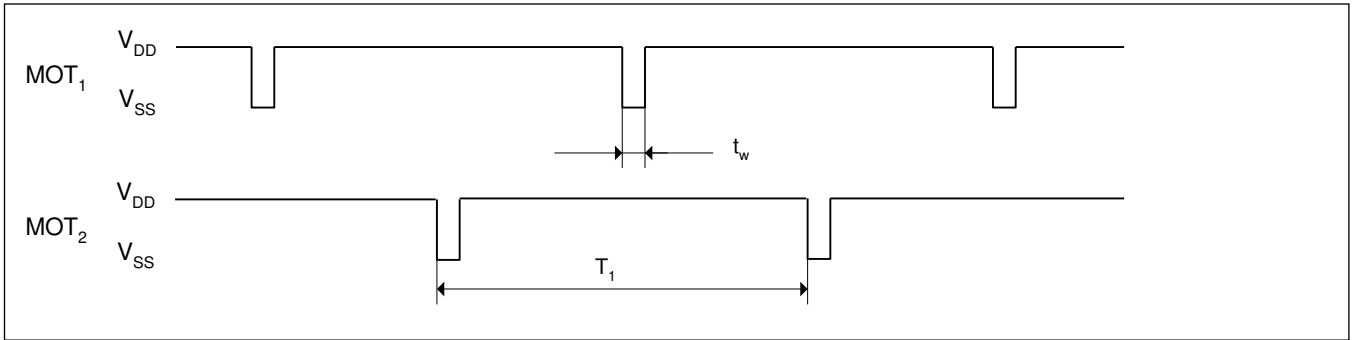

Fig. 3

Alarm Output Waveform

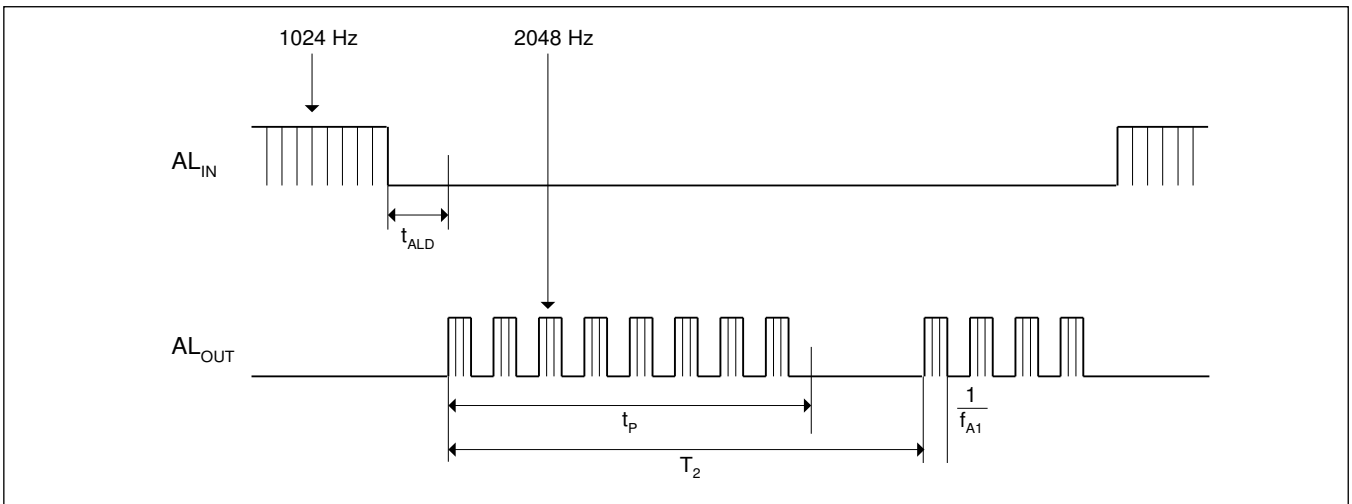

Fig. 4

## Functional Description

### Oscillator and Frequency Divider

The quartz oscillator consists of an inverter, internal feedback resistance to bias the input and integrated capacitors. The values of the integrated capacitors are selectable by metal mask. The oscillator is designed for 32768Hz.

### Motor Drive Output

The circuit contains two push-pull output buffers for driving bipolar stepping motors. Between two pulses, both P-channel transistor of the other buffer are conducting. The outputs are protected against inductive voltage spikes with diodes to both supply pins.

Both the motor pulse period and motor pulse width are programmable by metal mask over a wide range of values (see page 6 for available options).

### Alarm Output

The alarm is activated by connecting ALARM<sub>IN</sub> to V<sub>SS</sub> and is deactivated by opening the connection. A metal mask option is available to program a continuous activation of the alarm output.

The alarm output driver contains a push-pull output buffer to drive an external sound source by means of an external bipolar transistor. A metal mask option is available to allow the use of NPN or PNP-transistors.

The tone frequency, modulation frequency, modulation frequency and cycle time (ON/OFF time) are metal mask selectable.

### Test Mode

The ALARM<sub>IN</sub> pin fulfills three functions:

- For normal operation, the ALARM<sub>IN</sub> pin is left open. The circuit provides a square wave signal of 1024Hz, which can be used to tune the oscillator.
- If the pin is connected to V<sub>SS</sub>, the alarm signal is provided at pin 6.

If the ALARM<sub>IN</sub> pin is connected to V<sub>DD</sub>, all output frequencies are increased by a factor of 64, the alarm modulation of  $f_{A1} = 8\text{Hz}$  and  $f_A = 2\text{kHz}$  are suppressed.

## Test configuration

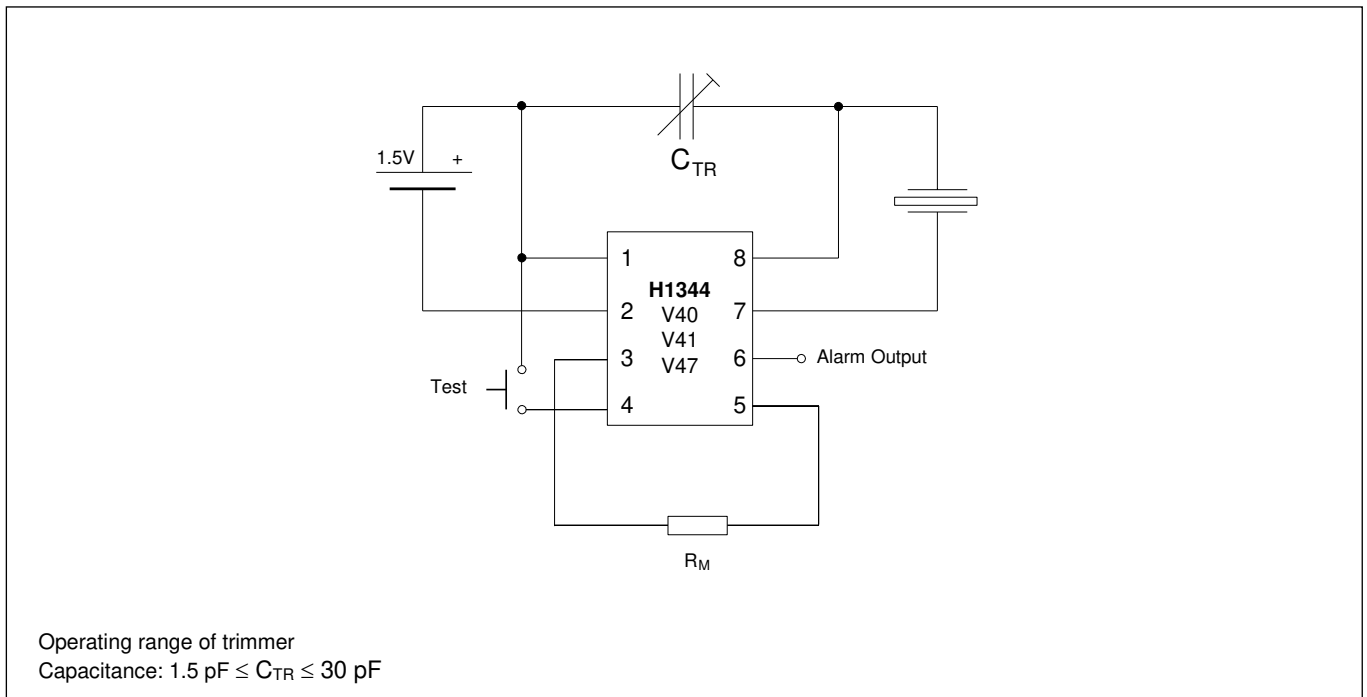

Fig. 5

## Pad Location Diagram

All dimensions in  $\mu\text{m}$

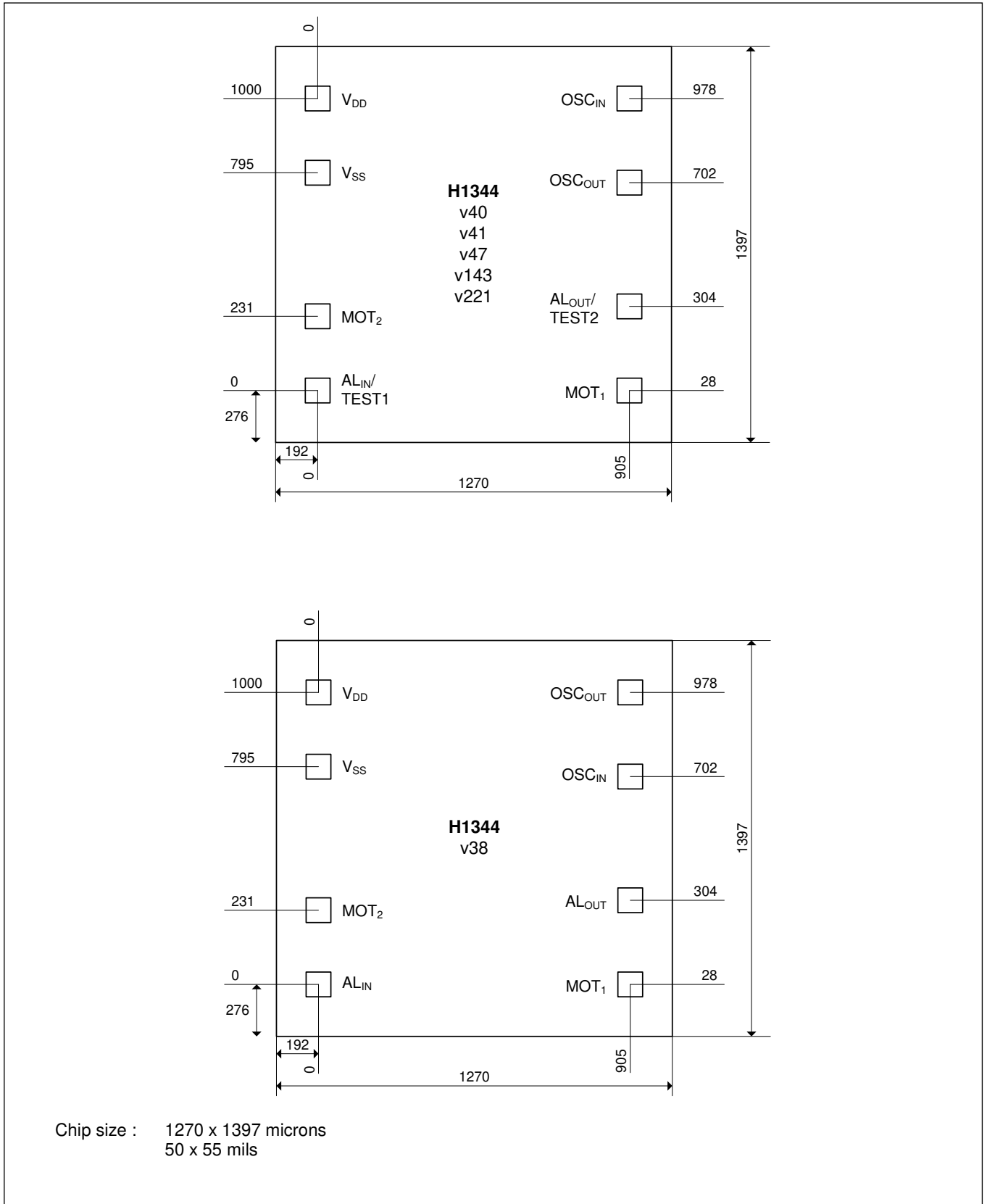
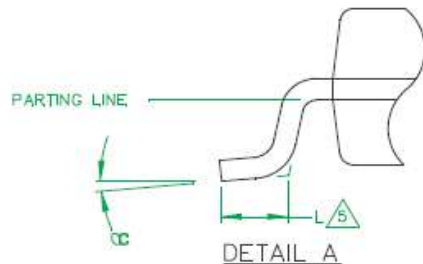
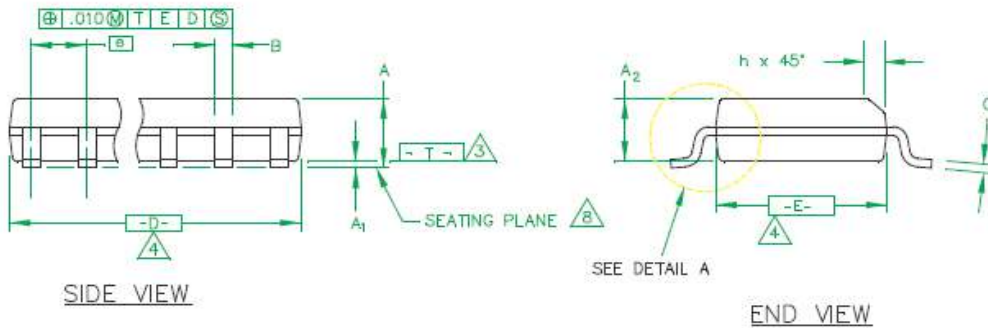
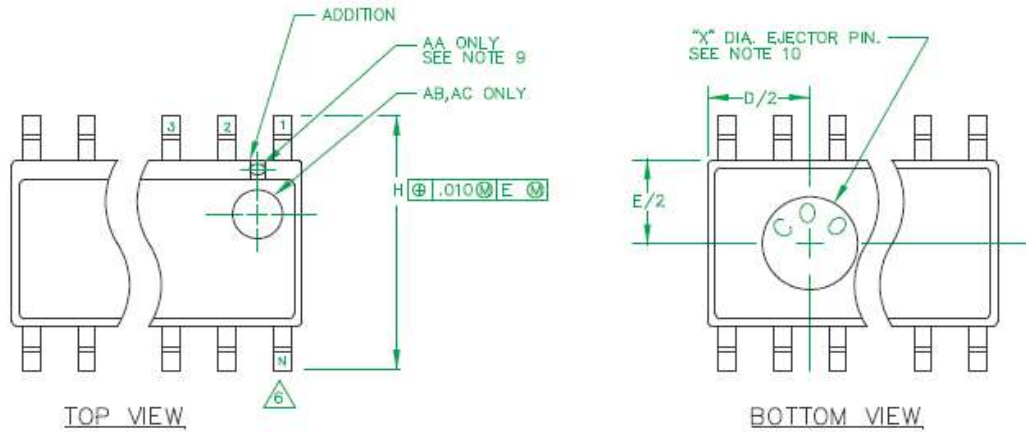

Fig. 6



Package Information  
SO-8



NOTES:

1. MAXIMUM DIE THICKNESS ALLOWABLE IS .015.
2. DIMENSIONING & TOLERANCES PER ANSI.Y14.5M - 1982.
3. "T" IS A REFERENCE DATUM.
4. "D" & "E" ARE REFERENCE DATUMS AND DO NOT INCLUDE MOLD FLASH OR PROTRUSIONS, BUT DOES INCLUDE MOLD MISMATCH AND ARE MEASURED AT THE MOLD PARTING LINE. MOLD FLASH OR PROTRUSIONS SHALL NOT EXCEED 0.006 INCHES AT END AND .010 INCHES AT WINDOW
5. "L" IS THE LENGTH OF TERMINAL FOR SOLDERING TO A SUBSTRATE.
6. "N" IS THE NUMBER OF TERMINAL POSITIONS.
7. TERMINAL POSITIONS ARE SHOWN FOR REFERENCE ONLY.
8. FORMED LEADS SHALL BE PLANAR WITH RESPECT TO ONE ANOTHER WITHIN .003 INCHES AT SEATING PLANE.
9. THE APPEARANCE OF PIN #1 I.D ON THE 8 LD IS OPTIONAL, ROUND TYPE ON SINGLE LEADFRAME AND RECTANGULAR TYPE ON MATRIX LEADFRAME.
10. COUNTRY OF ORIGIN LOCATION ON PACKAGE BOTTOM IS OPTIONAL AND DEPENDS ON ASSEMBLY LOCATION.
11. CONTROLLING DIMENSION: INCHES.
12. THIS PART IS COMPLIANT WITH JEDEC STANDARD MS-012, VARIATION AA, AB & AC.

THIS TABLE IN MILLIMETERS

SYMBOL	COMMON DIMENSIONS			NOTE VARIATIONS	3 D			5 N
	MIN.	NOM.	MAX.		MIN.	NOM.	MAX.	
A	1.55	1.63	1.73	AA	4.80	4.93	4.98	8
A <sub>1</sub>	0.127	0.15	0.25	AB	8.58	8.69	8.74	14
A <sub>2</sub>	1.40	1.47	1.55	AC	9.80	9.93	9.98	16
B	0.35	0.41	0.49					
C	0.19	0.20	0.25					
D	SEE VARIATIONS			3				
E	3.81	3.94	3.99					
e	1.27 BSC							
H	5.84	5.99	6.20					
h	0.25	0.33	0.41					
L	0.41	0.64	0.89					
N	SEE VARIATIONS			5				
α	0°	5°	8°					
X	2.16	2.36	2.54					



Ordering Information

Versions

The versions below are considered standards. For the other delivery form, please contact EM Microelectronic-Marin S.A. Please make sure to give the complete part number when ordering.

Part Number	Version	Motor		Alarm Output				Integrated Capacitance		Alarm Output Transistor	Package	Delivery Form
		Period (T <sub>1</sub> )	Pulse width (t <sub>w</sub> )	Frequency (f <sub>A</sub> )	Modulation (f <sub>A1</sub> )	Cycle time (T <sub>2</sub> )	Pulse duration (t <sub>p</sub> )	(C <sub>IN</sub> )	(C <sub>OUT</sub> )			
EM1344V143DL8A+	V143 )	2s	46.8ms	--	--	--	--	17pF	25pF	--	DIL8	Stick
EM1344V143SO8A+											8 pin SOIC	Stick
EM1344V143SO8B+											8 pin SOIC	Tape & Reel
EM1344V221DL8A+	V221	2s	1s	--	--	--	--	9pF	20pF	--	DIL8	Stick
EM1344V221SO8A+											8 pin SOIC	Stick
EM1344V221SO8B+											8 pin SOIC	Tape & Reel

\*) Supply voltage range of 1.4V – 2.8V

EM Microelectronic-Marin SA ("EM") makes no warranties for the use of EM products, other than those expressly contained in EM's applicable General Terms of Sale, located at <http://www.emmicroelectronic.com>. EM assumes no responsibility for any errors which may have crept into this document, reserves the right to change devices or specifications detailed herein at any time without notice, and does not make any commitment to update the information contained herein.

No licenses to patents or other intellectual property rights of EM are granted in connection with the sale of EM products, neither expressly nor implicitly.

In respect of the intended use of EM products by customer, customer is solely responsible for observing existing patents and other intellectual property rights of third parties and for obtaining, as the case may be, the necessary licenses.

**Important note: The use of EM products as components in medical devices and/or medical applications, including but not limited to, safety and life supporting systems, where malfunction of such EM products might result in damage to and/or injury or death of persons is expressly prohibited, as EM products are neither destined nor qualified for use as components in such medical devices and/or medical applications. The prohibited use of EM products in such medical devices and/or medical applications is exclusively at the risk of the customer**