

PE7/PE8/PE8 Series

Combination



Specifications:

Rated Voltage: 250VAC Maximum - 50/60 Hz

Rated Current: 115VAC 250VAC
 3A 3A
 6A 6A

Current Overload: 6X for 8 Seconds

Hi-Pot Test (1 min):

Line to Ground 1500VAC
 Line to Line 1768VDC

Insulation Resistance: $9 \times 10^9 \Omega$ at 100VDC

Ambient Temperature: 40°C Max. at Rated Current

Humidity Range: 0% to 95% R.H.

Termination:

- IEC Receptacle
- Wire Wrap/Solder

Maximum Leakage Current:

Each Line to Ground **PE7, PE 8, PE9**
 115VAC, 60Hz: 0.25mA
 250VAC, 50Hz: 0.40mA

Voltage Select Card: Installed in 120VAC position unless otherwise specified

Agency Approvals:



Refer to Page 62 for Ordering Instructions

Features:

- RFI Filter Module Combines IEC Connector, Fusing, and Voltage Select Features in One Unit
- PE7 Series Filters Provide 20% More Differential Mode Attenuation Than Comparable Units
- Accepts Either U.S. or European Standard Fuse Sizes

PE7 Series Simplified Schematic

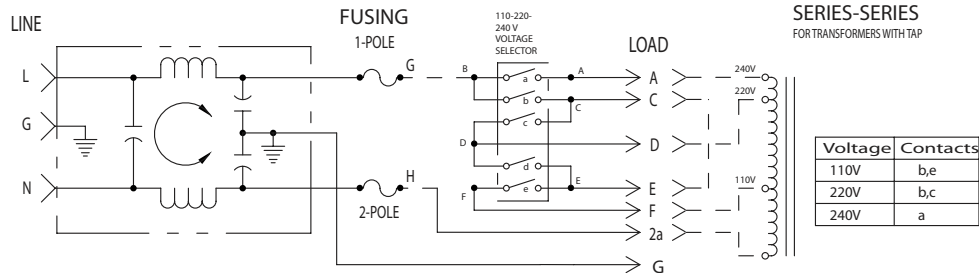

Nominal Current Rating	Part Number	Termination Line/Load	MINIMUM INSERTION LOSS - dB (50 ohm Circuit)						
			MODE	Frequency - MHz					
				.15	.50	1.0	5.0	10	30
3A	PE7XXX03 PE8XXX03 PE9XXX03	IEC/Solder Tabs	Common	18	24	30	45	45	50
			Differential	8	18	24	46	50	40
6A	PE7XXX06 PE8XXX06 PE9XXX06	IEC/Solder Tabs	Common	10	19	24	39	44	50
			Differential	8	18	24	39	40	40



PE7 Series Simplified Schematic

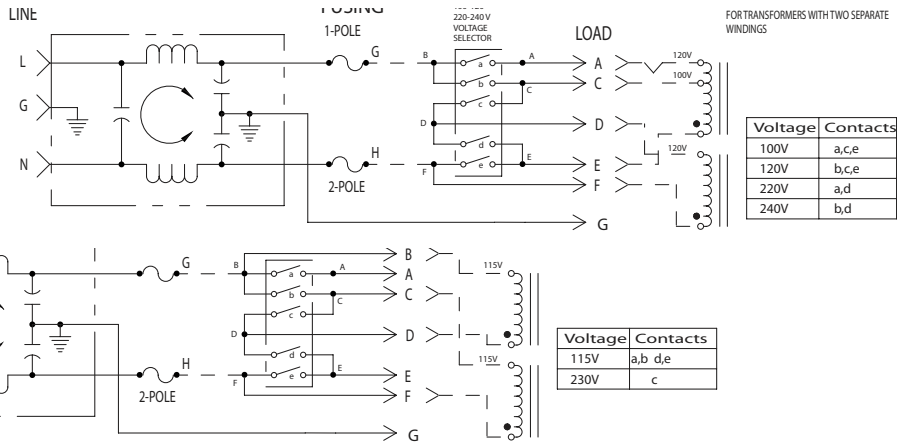

PE8 Series Simplified Schematic

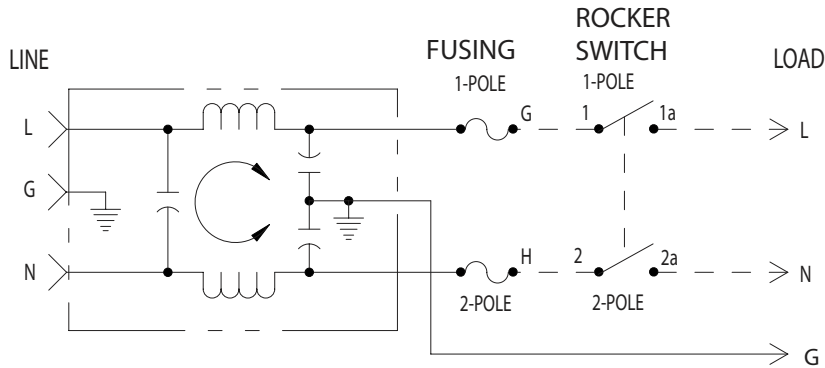

PE9 Series Simplified Schematic

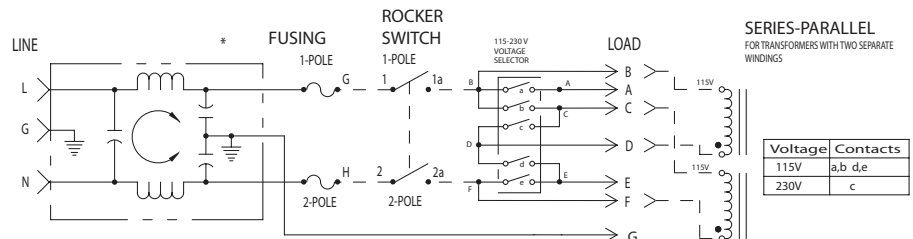
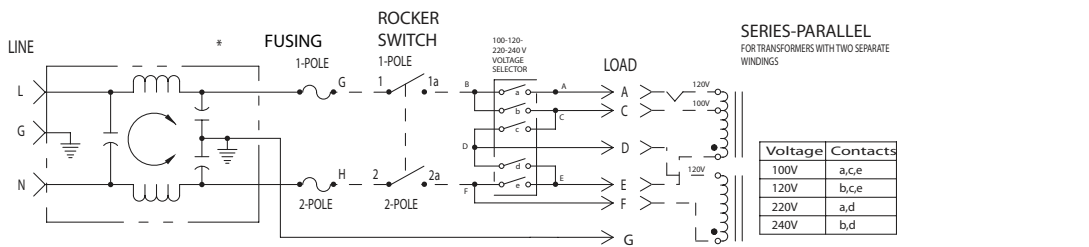
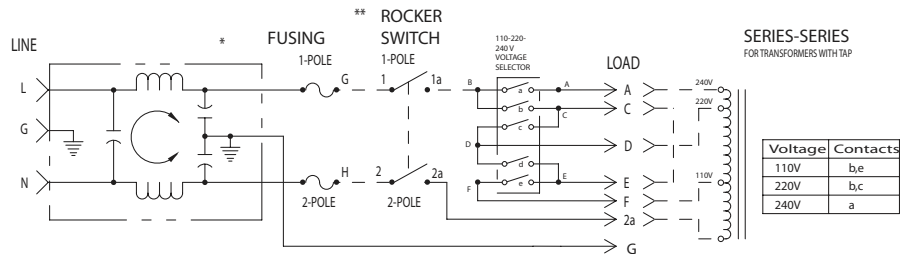

Dimensions are in inches and millimeters unless otherwise specified. Values in parentheses are metric equivalents.



Curtis Industries
A Division of Powers Holdings, Inc.

PE7/PE8/PE8 Series (continued)

PE7/PE8 Snap-Mount Series

(3 and 6Amp)
Dimensions

Refer to Page 62
for Standard
Mounting Cutouts

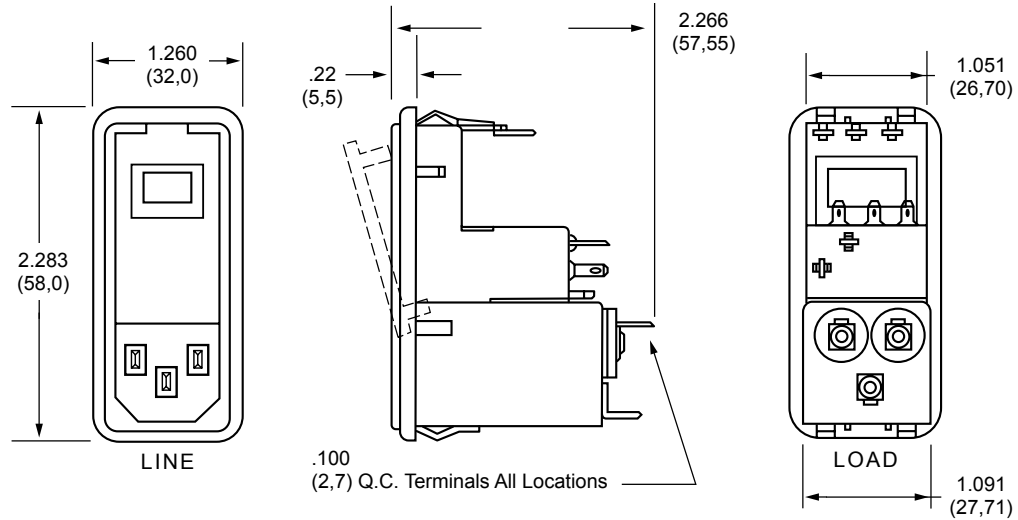

PE7/PE8 Screw-Mount Series

(3 and 6Amp)
Dimensions

Refer to Page 62
for Standard
Mounting Cutouts

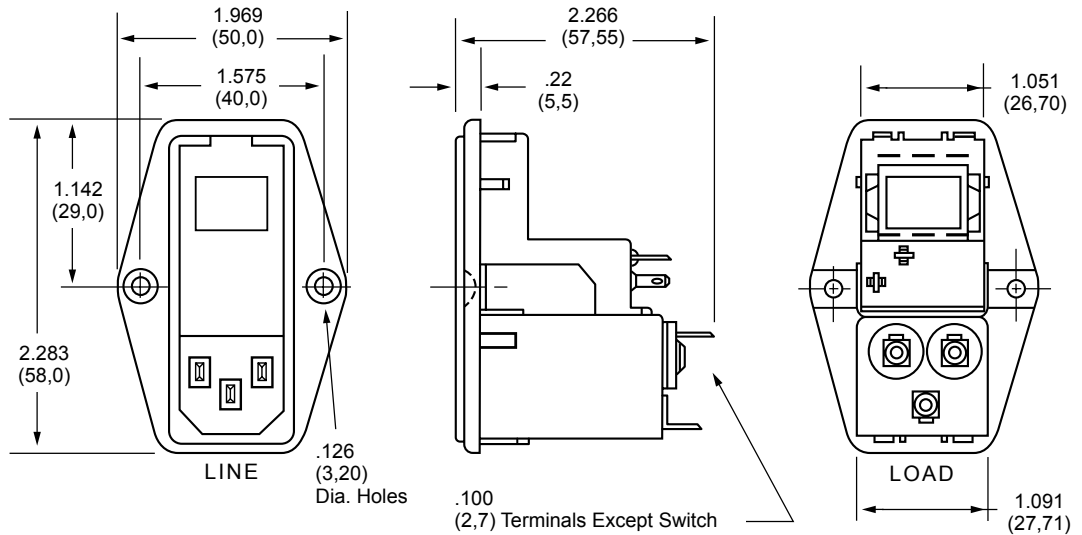

PE9(3 and 6Amp) Dimensions

Refer to Standard
Mounting Cutouts
Below

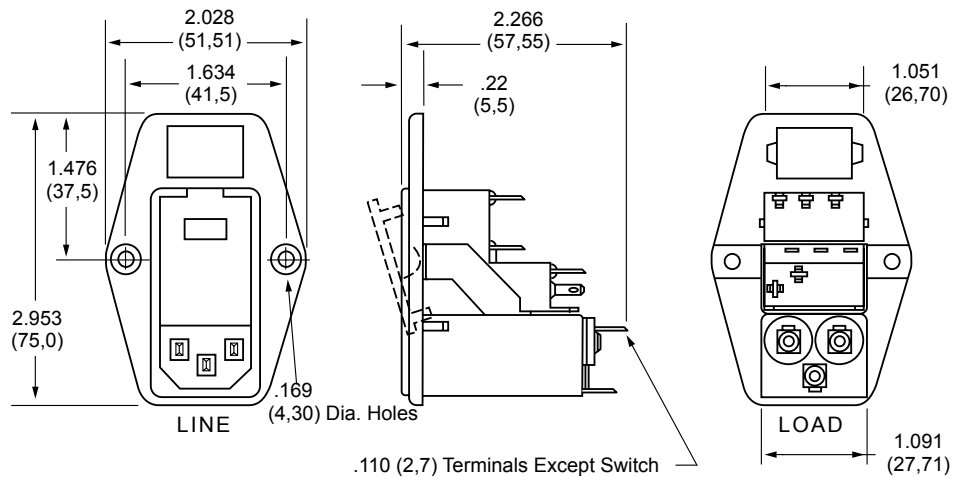

How to Order

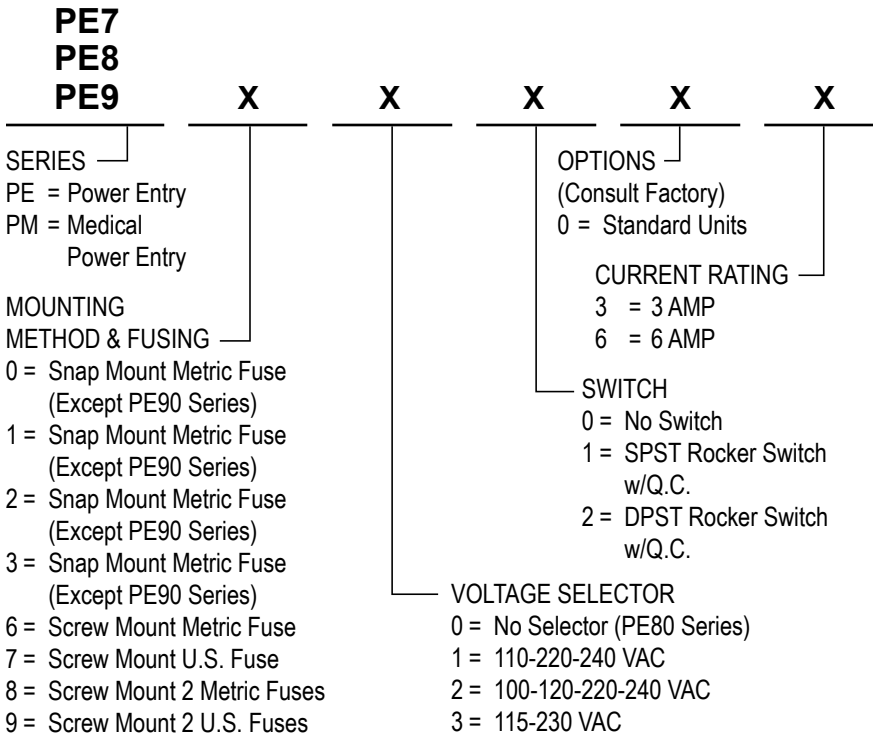

INSTALLATION INSTRUCTION IMPORTANT – CHANGING FUSE/VOLTAGE

PE7/PE8/PE9

To change fuse, remove power cord and open the front cover on the module. Remove fuse holder and replace fuse. Reinsert fuse holder and close cover. To change the operating voltage on the PE7 and PE9 Series, remove the power cord and open front cover. Rotate voltage select wheel until desired voltage appears in window of cover.

- Filter shipped without fuse.

Always use caution when selecting and changing fuses and voltage requirements. Curtis Industries is not responsible for malfunction due to improper installation/selection of fuse and/or voltage select.

Standard Mounting Cutouts

