

REVISION(S)			
LTR	DESCRIPTION	INIT	APP'D
O	ECN: OS60-0091-04	E.T 04/08/04	B.P 04/08/04
A	ECR-06-011657	E.T 6/2/06	V.K 6/26/06

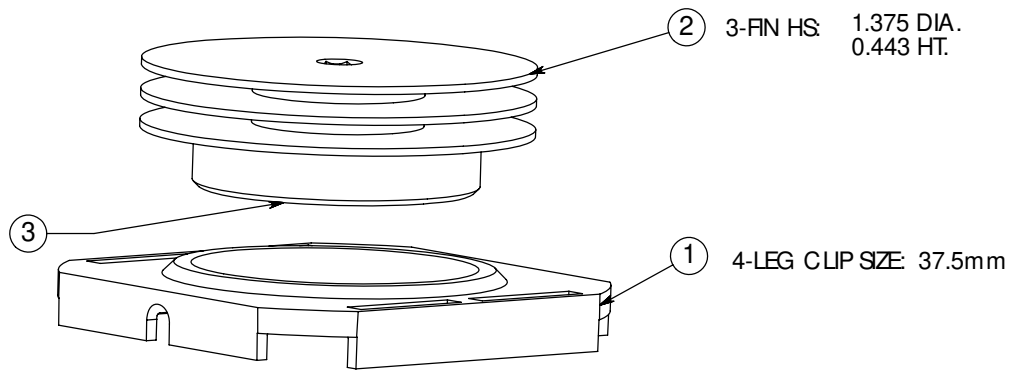

NOTE:

- MATERIAL:
HEAT SINK: ALUM. (BLACK ANODIZE)
CLIP: BLACK PEI (UL94-VO)
- BEFORE THE HEAT SINK APPLICATION, THE USER SHOULD IDENTIFY THE SPECIFICATION OF MAXIMUM LOAD ON THE BGA PACKAGE

HEAT SINK TORQUE SPECIFICATIONS CONVERTED TO FORCE

BARE DIE PACKAGE:
2.0 INCH - LB TORQUE = 8.1 LBS FORCE
2.5 INCH - LB TORQUE = 10.1 LBS FORCE

FULL SIZE LID PACKAGE:
2.0 INCH - LB TORQUE = 6.9 LBS FORCE
2.5 INCH - LB TORQUE = 8.7 LBS FORCE
- REMOVE CLIP WITH REMOVAL TOOL P/N: 1542616-1
- RoHS COMPLIANT AND CERTIFIED.

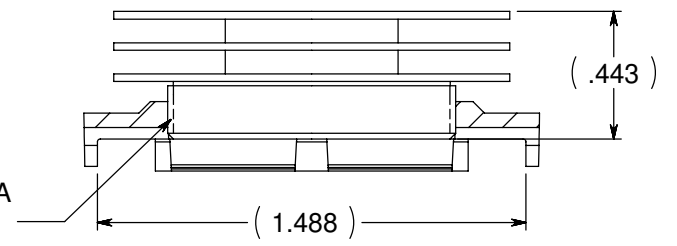
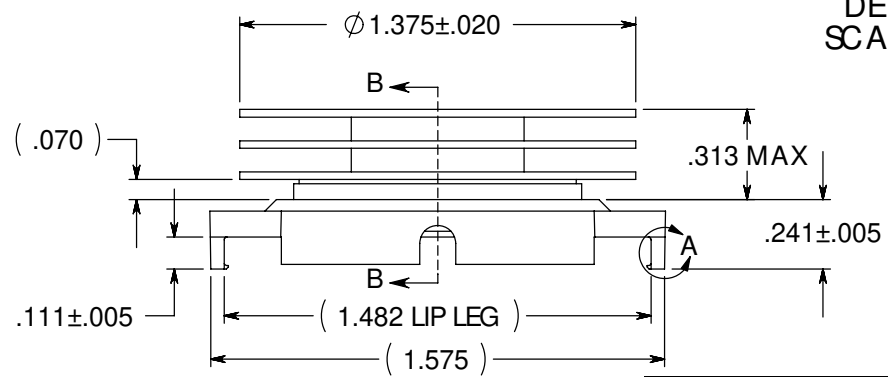
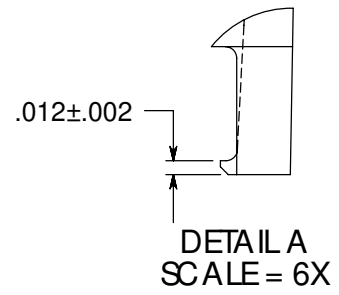

Power	° C/W @ Ambient	° C/W @ 200 LFM	° C/W @ 400 LFM	° C/W @ 600 LFM
5 Watts	11.06	5.44	3.45	2.55
10 Watts	10.31	5.72	3.68	2.69
15 Watts	9.48	5.89	3.73	2.82

CUSTOMER DRAWING

SPECIFICATIONS ARE SUBJECT TO CHANGE WITHOUT NOTICE

ITEM	DESCRIPTION	QTY
1	MOUNTING CLIP	1
2	HEAT SINK	1
3	INTERFACE	1

tyco / Electronics Attleboro Falls Massachusetts 02763

UNLESS OTHERWISE SPECIFIED TO LEFTRANCES ARE: .XX ± . .XXX ± . .XXXX ± . ANGLES ± *

DRAWN BY: ETAO DATE: 04/08/04 MATERIAL: SEE NOTE

ENGINEER: B. PETROCELLI DATE: 04/08/04 FINISH: SEE NOTE

FILENAME: PROJECT: SYSTEM:

CONFIDENTIAL PROPERTY OF TYCO ELECTRONICS NOT TO BE DISCLOSED TO OTHERS REPRODUCED OR USED FOR ANY PURPOSES EXCEPT AS AUTHORIZED IN WRITING BY AN AUTHORIZED OFFICIAL OF TYCO. MUST BE RETURNED TO TYCO ON DEMAND, ON COMPLETION OF ORDERS OR OTHER PURPOSES FOR WHICH LENT.

TITLE: 37.5mm HS ASSY (HTS405-U)

DIMENSIONS ARE IN: INCHES SCALE: 1.5:1 PART NO.: 3-1542006-5 SHEET: 1 OF 1

TYPED ANGLE PROJECTION: SIZE: A DWG. NO.: C-3-1542006-5 REV: A