



DM74ALS165

8-Bit Parallel In/Serial Out Shift Register

Features

- Complementary outputs
- Direct overriding load (data) inputs
- Gated clock inputs
- Parallel-to-serial data conversion

General Description

The DM74ALS165 is an 8-bit serial register that, when clocked, shifts the data toward serial output, \overline{Q}_H . Parallel-in access to each stage is provided by eight individual direct data inputs that are enabled by a low level at the SH/\overline{LD} input. The DM74ALS165 also features a clock inhibit function and a complemented serial output, \overline{Q}_H .

Clocking is accomplished by a LOW-to-HIGH transition of the CLK input while SH/\overline{LD} is held HIGH and CLK INH is held LOW. The functions of the CLK and CLK INH (clock inhibit) inputs are interchangeable. Since a LOW CLK input and a LOW-to-HIGH transition of CLK INH will also accomplish clocking, CLK INH should be changed to the high level only while the CLK input is HIGH. Parallel loading is inhibited when SH/\overline{LD} is held HIGH. The parallel inputs to the register are enabled while SH/\overline{LD} is LOW independently of the levels of CLK, CLK INH, or SER inputs.

Ordering Information

Order Number	Package Number	Package Description
DM74ALS165M	M16A	16-Lead Small Outline Integrated Circuit (SOIC), JEDEC MS-012, 0.150" Narrow

Devices also available in Tape and Reel. Specify by appending the suffix letter "X" to the ordering number.

Connection Diagram

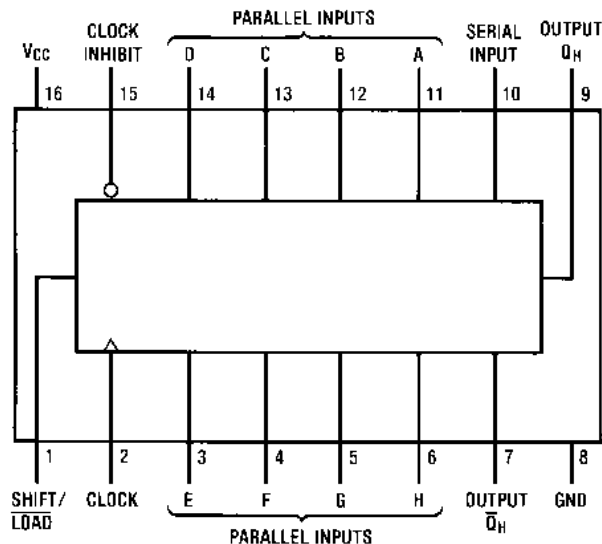

Function Table

Inputs					Internal Outputs		Output Q_H
Shift/Load	Clock Inhibit	Clock	Serial	Parallel A...H	Q_A	Q_B	
L	X	X	X	a...h	a	b	h
H	L	L	X	X	Q_{A0}	Q_{B0}	Q_{H0}
H	L	↑	H	X	H	Q_{An}	Q_{Gn}
H	L	↑	L	X	L	Q_{An}	Q_{Gn}
H	↑	L	H	X	H	Q_{An}	Q_{Gn}
H	↑	L	L	X	L	Q_{An}	Q_{Gn}
H	H	X	X	X	Q_{A0}	Q_{B0}	Q_{H0}

H = HIGH Level (steady-state)

L = LOW Level (steady-state)

X = Don't Care (any input, including transitions)

↑ = Transition from LOW-to-HIGH level

a...h = The level of steady-state input at inputs A through H, respectively

Q_{A0} , Q_{B0} , Q_{H0} = The level of Q_A , Q_B , or Q_H , respectively, before the indicated steady-state input conditions were established

Q_{An} , Q_{Gn} = The level of Q_A or Q_G , respectively, before the most recent ↑ transition of the clock

Logic Diagram

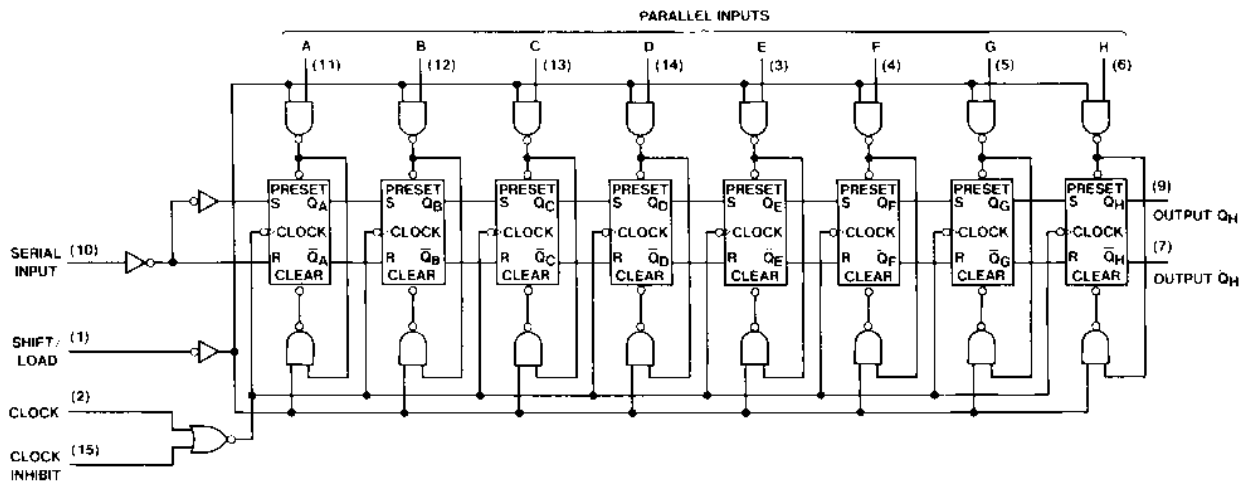

Timing Diagram

Typical Shift, Load, and Inhibit Sequences

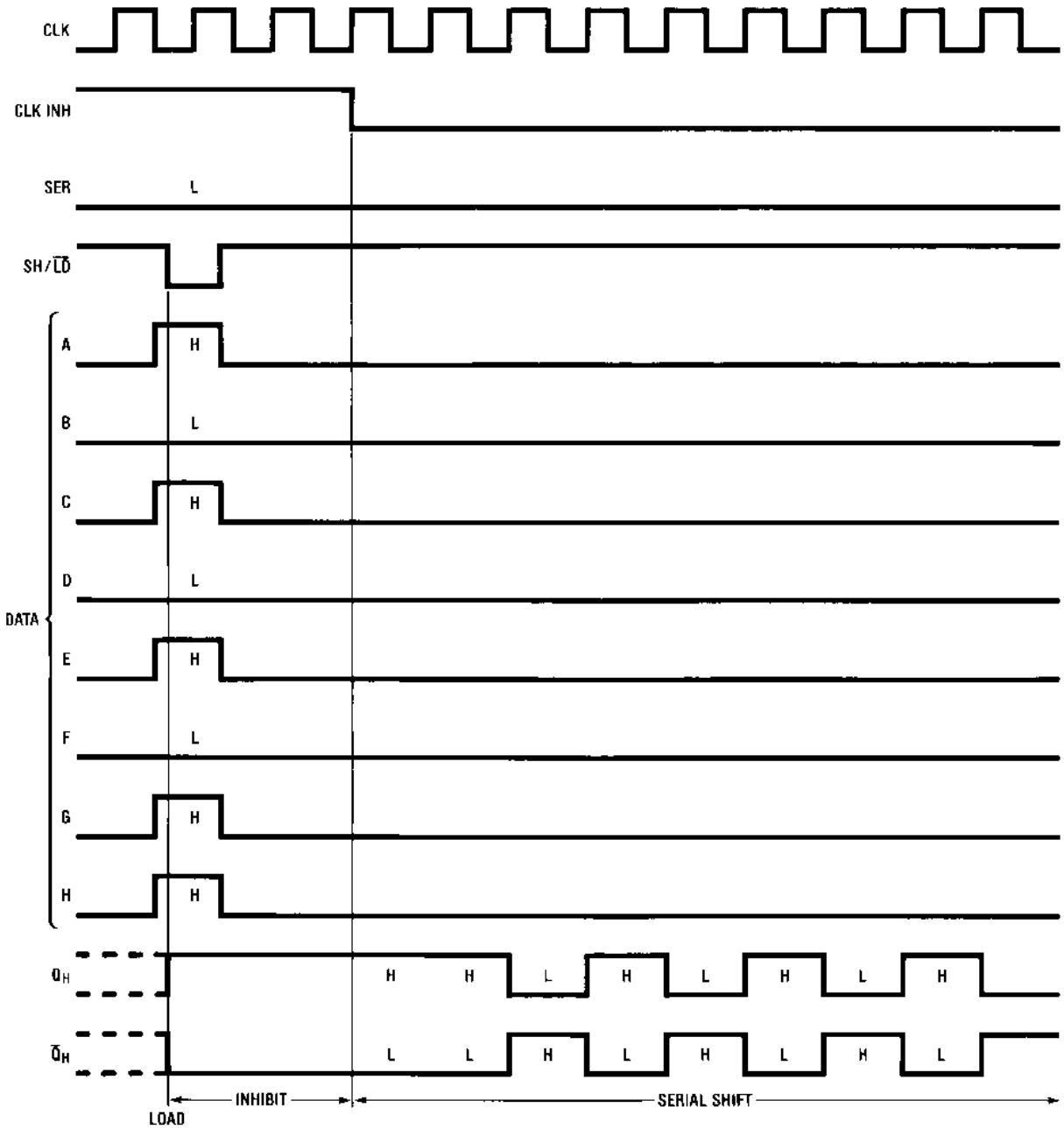

Absolute Maximum Ratings

Stresses exceeding the absolute maximum ratings may damage the device. The device may not function or be operable above the recommended operating conditions and stressing the parts to these levels is not recommended. In addition, extended exposure to stresses above the recommended operating conditions may affect device reliability. The absolute maximum ratings are stress ratings only.

Symbol	Parameter	Rating
V_{CC}	Supply Voltage	7V
V_I	Input Voltage	7V
T_A	Operating Free Air Temperature Range	0°C to +70°C
T_{STG}	Storage Temperature Range	-65°C to +150°C
θ_{JA}	Typical Thermal Resistance	104.0°C/W

Recommended Operating Conditions

The Recommended Operating Conditions table defines the conditions for actual device operation. Recommended operating conditions are specified to ensure optimal performance to the datasheet specifications. Fairchild does not recommend exceeding them or designing to absolute maximum ratings.

Symbol	Parameter	Min.	Typ.	Max.	Units
V_{CC}	Supply Voltage	4.5	5	5.5	V
V_{IH}	HIGH Level Input Voltage	2			V
V_{IL}	LOW Level Input Voltage			0.8	V
I_{OH}	HIGH Level Output Current			-0.4	mA
I_{OL}	LOW Level Output Current			8	mA
f_{CLOCK}	Clock Frequency	45			MHz
t_W	Pulse Duration	CLK HIGH	11		ns
		CLK LOW	11		
		Load	12		
t_{SU}	Setup Time	SH/ \overline{LD}	10		ns
		Data	10		
t_{SU}	Setup Time	CLK INH \downarrow before CLK	11		ns
		Serial before CLK	10		
t_H	Hold Time	4			ns
T_A	Operating Free Air Temperature	0		70	°C

Electrical Characteristics

Over recommended operating free air temperature range (unless otherwise noted).

Symbol	Parameter	Conditions	Min.	Typ. ⁽¹⁾	Max.	Units
V_{IK}	Input Clamp Voltage	$V_{CC} = 4.5V, I_I = -18mA$			-1.5	V
V_{OH}	HIGH Level Output Voltage	$I_{OH} = -0.4mA$ $V_{CC} = 4.5V \text{ to } 5.5V$	$V_{CC} - 2$			V
V_{OL}	LOW Level Output Voltage	$V_{CC} = 4.5V$ $I_{OL} = 4mA$ $I_{OL} = 8mA$		0.25 0.35	0.4 0.5	V
I_I	Input Current at Max Input Voltage	$V_{CC} = 5.5V, V_I = 7V$			0.1	mA
I_{IH}	HIGH Level Input Current	$V_{CC} = 5.5V, V_I = 2.7V$			20	μA
I_{IL}	LOW Level Input Current	$V_{CC} = 5.5V, V_I = 0.4V$			-0.1	mA
$I_O^{(2)}$	Output Drive Current	$V_{CC} = 5.5V, V_O = 2.25V$	-30		-112	mA
I_{CC}	Supply Current	$V_{CC} = 5.5V^{(3)}$		16	24	mA

Notes:

- All typical values are at $V_{CC} = 5V, T_A = 25^\circ C$.
- The output conditions have been chosen to produce a current that closely approximates one half of the true short-circuit output current, I_{OS} .
- With the outputs open, CLK INH and CLK at 4.5V, and a clock pulse applied to the SH/ \overline{LD} input, I_{CC} is measured first with the parallel inputs at 4.5V, then with the parallel inputs grounded.

Switching Characteristics

Over recommended free air temperature range. All typical values are measured at $V_{CC} = 5V, T_A = 25^\circ C$.

Symbol	Parameter	Input	Output	Conditions	Min.	Typ.	Max.	Units
f_{MAX}	Maximum Frequency			$V_{CC} = 4.5V \text{ to } 5.5V,$ $C_L = 50pF,$ $R_L = 500\Omega$ $T_A = \text{Min. to Max.}$	45	60		MHz
t_{PLH}	Propagation Delay Time, LOW-to-HIGH Level Output	Load	Q_H or \overline{Q}_H		4	13	20	ns
t_{PHL}	Propagation Delay Time, HIGH-to-LOW Level Output	Load	Q_H or \overline{Q}_H		4	14	22	ns
t_{PLH}	Propagation Delay Time, LOW-to-HIGH Level Output	CLK	Q_H or \overline{Q}_H		3	7	13	ns
t_{PHL}	Propagation Delay Time, HIGH-to-LOW Level Output	CLK	Q_H or \overline{Q}_H		3	9	14	ns
t_{PLH}	Propagation Delay Time, LOW-to-HIGH Level Output	H	Q_H		3	7	13	ns
t_{PHL}	Propagation Delay Time, HIGH-to-LOW Level Output	H	Q_H		3	9	16	ns
t_{PLH}	Propagation Delay Time, LOW-to-HIGH Level Output	H	\overline{Q}_H		2	8	15	ns
t_{PHL}	Propagation Delay Time, HIGH-to-LOW Level Output	H	\overline{Q}_H		3	9	16	ns

Physical Dimensions

Dimensions are in millimeters unless otherwise noted.

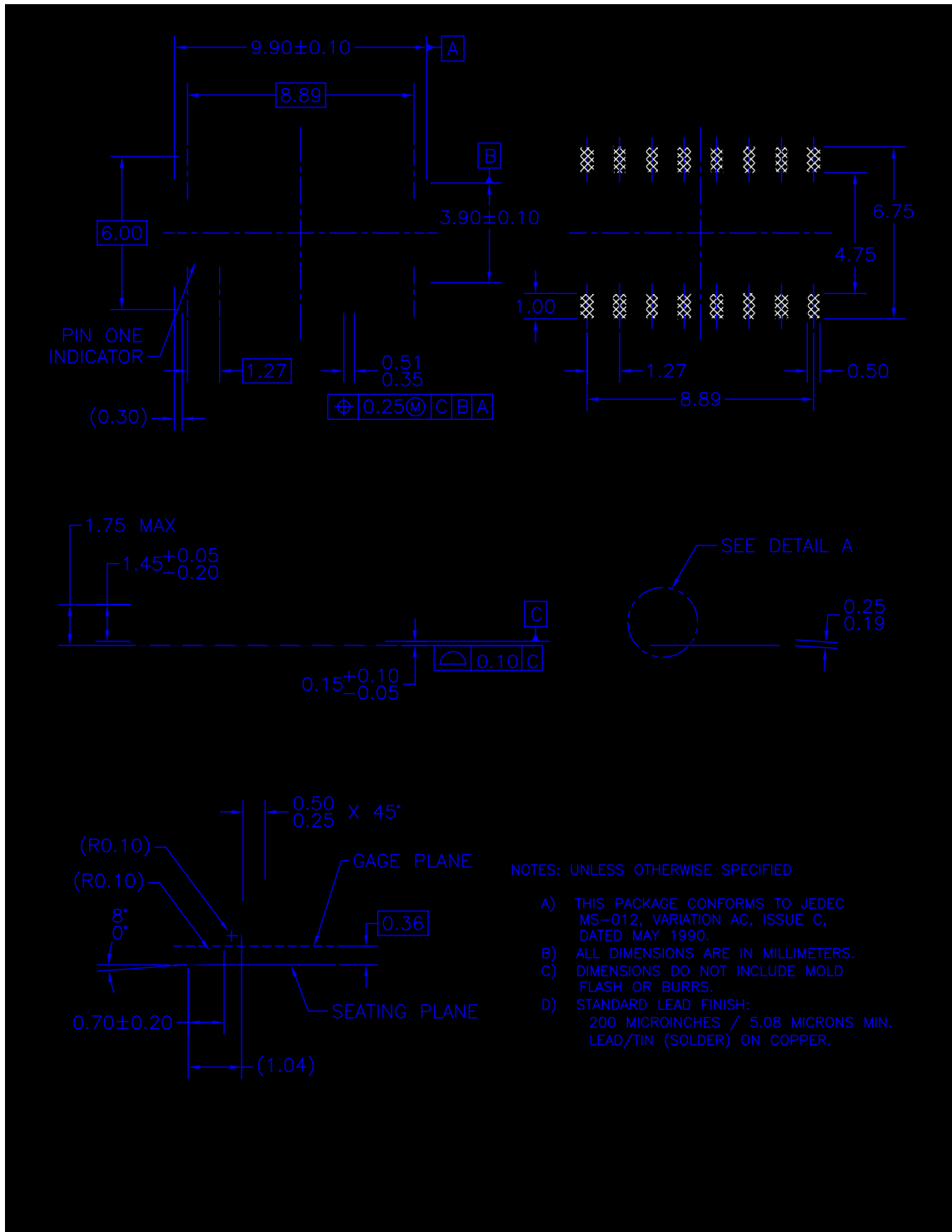

Figure 1. 16-Lead Small Outline Integrated Circuit (SOIC), JEDEC MS-012, 0.150" Narrow Package Number M16A

