

# Current Transducer LA 200-P

For the electronic measurement of currents: DC, AC, pulsed..., with galvanic separation between the primary circuit and the secondary circuit.

$$I_{PN} = 200 \text{ A}$$



16044

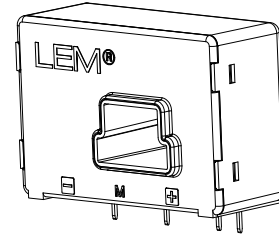

## Electrical data

$I_{PN}$	Primary nominal current rms	200	A			
$I_{PM}$	Primary current, measuring range	0 .. $\pm 300$	A			
$R_M$	Measuring resistance @	$T_A = 70^\circ\text{C}$	$T_A = 85^\circ\text{C}$			
		$R_{M \min}$ $R_{M \max}$	$R_{M \min}$ $R_{M \max}$			
		with $\pm 12 \text{ V}$	@ $\pm 200 \text{ A}_{\max}$	0 30	0 26	$\Omega$
			@ $\pm 250 \text{ A}_{\max}$	0 8	0 4	$\Omega$
		with $\pm 15 \text{ V}$	@ $\pm 200 \text{ A}_{\max}$	0 60	0 56	$\Omega$
	@ $\pm 300 \text{ A}_{\max}$	0 12	0 8	$\Omega$		
$I_{SN}$	Secondary nominal current rms	100	mA			
$K_N$	Conversion ratio	1 : 2000				
$U_C$	Supply voltage ( $\pm 5 \%$ )	$\pm 12 \dots 15$	V			
$I_C$	Current consumption	16 (@ $\pm 15 \text{ V}$ ) + $I_S$	mA			

## Accuracy - Dynamic performance data

X	Accuracy @ $I_{PN}$ , $T_A = 25^\circ\text{C}$	@ $\pm 15 \text{ V} (\pm 5 \%)$	$\pm 0.40$	%
		@ $\pm 12 \dots 15 \text{ V} (\pm 5 \%)$	$\pm 0.65$	%
$\epsilon_L$	Linearity error		< 0.15	%
$I_O$	Offset current @ $I_P = 0$ , $T_A = 25^\circ\text{C}$	Typ		Max
				$\pm 0.20$
$I_{OM}$	Magnetic offset current <sup>1)</sup> @ $I_P = 0$ and specified $R_M$ , after an overload of $3 \times I_{PN}$		$\pm 0.10$	$\pm 0.25$
			$\pm 0.15$	$\pm 0.55$
$I_{OT}$	Temperature variation of $I_O$	$0^\circ\text{C} \dots +70^\circ\text{C}$	$\pm 0.10$	$\pm 0.25$
		$-40^\circ\text{C} \dots +85^\circ\text{C}$	$\pm 0.15$	$\pm 0.55$
$t_{ra}$	Reaction time		< 500	ns
$t_r$	Step response time <sup>2) 3)</sup> to 90 % of $I_{PN}$		< 1	$\mu\text{s}$
$di/dt$	$di/dt$ accurately followed <sup>3)</sup>		> 200	A/ $\mu\text{s}$
BW	Frequency bandwidth (-1 dB)		DC .. 100	kHz

## General data

$T_A$	Ambient operating temperature	-40 .. +85	$^\circ\text{C}$
$T_S$	Ambient storage temperature	-40 .. +90	$^\circ\text{C}$
$R_S$	Secondary coil resistance @	$T_A = 70^\circ\text{C}$	76 $\Omega$
		$T_A = 85^\circ\text{C}$	80 $\Omega$
m	Mass		40 g
		Standard	EN 50178: 1997

Notes: <sup>1)</sup> The result of the coercive field of the magnetic circuit

<sup>2)</sup> With a  $di/dt$  of 100 A/ $\mu\text{s}$

<sup>3)</sup> The primary conductor is best filling the through-hole and/or the return of the primary conductor is above the top of the transducer.

## Features

- Closed loop (compensated) current transducer using the Hall effect
- Insulating plastic case recognized according to UL 94-V0.

## Advantages

- Excellent accuracy
- Very good linearity
- Low temperature drift
- Optimized response time
- Wide frequency bandwidth
- No insertion losses
- High immunity to external interference
- Current overload capability.

## Applications

- AC variable speed drives and servo motor drives
- Static converters for DC motor drives
- Battery supplied applications
- Uninterruptible Power Supplies (UPS)
- Switched Mode Power Supplies (SMPS)
- Power supplies for welding applications.

## Application domain

- Industrial.

## Current Transducer LA 200-P

### Isolation characteristics

$U_d$	Rms voltage for AC insulation test, 50 Hz, 1 min	3	kV
$\dot{U}_w$	Impulse withstand voltage 1.2/50 $\mu$ s	7	kV
$U_e$	Partial discharge extinction voltage rms @ 10 pc	> 1.8	kV
		Min	
$d_{cp}$	Creepage distance	6.7	mm
$d_{cl}$	Clearance	6.7	mm
$CTI$	Comparative Tracking Index (group IIIa)	175	

### Applications examples

According to EN 50178 and IEC 61010-1 standards and following conditions:

- Over voltage category OV 3
- Pollution degree PD2
- Non-uniform field

	EN 50178	IEC 61010-1
$d_{cp}, d_{cl}, \dot{U}_w$	Rated insulation voltage	Nominal voltage
Basic insulation	600 V	600 V
Reinforced insulation	300 V	300 V

### Safety

This transducer must be used in limited-energy secondary circuits according to IEC 61010-1.



This transducer must be used in electric/electronic equipment with respect to applicable standards and safety requirements in accordance with the manufacturer's operating instructions.



Caution, risk of electrical shock

When operating the transducer, certain parts of the module can carry hazardous voltage (eg. primary busbar, power supply).

Ignoring this warning can lead to injury and/or cause serious damage.

This transducer is a build-in device, whose conducting parts must be inaccessible after installation.

A protective housing or additional shield could be used.

Main supply must be able to be disconnected.

## Dimensions LA 200-P (in mm)

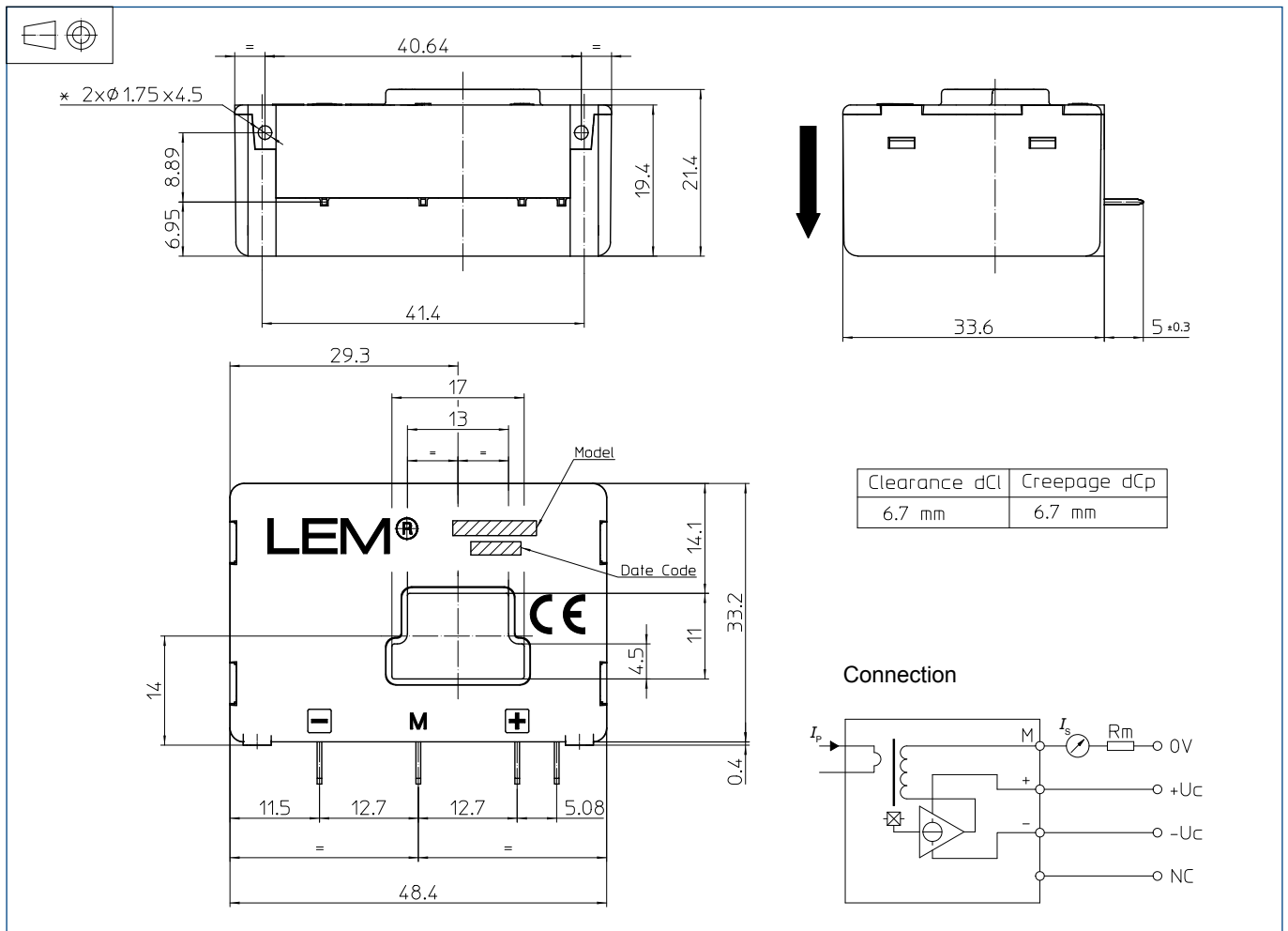

### Mechanical characteristics

- General tolerance  $\pm 0.2$  mm
- Primary through-hole 17 x 11 mm
- Fastening & connection of secondary 4 pins
  - 0.63 x 0.56 mm
  - Recommended PCB hole 0.9 mm
- Supplementary fastening 2 holes  $\varnothing 1.75$  mm
  - Recommended PCB hole 2.4 mm
  - Recommended screws PT KA 22 x 6
  - Recommended fastening torque 0.5 N·m

### Remarks

- $I_s$  is positive when  $I_p$  flows in the direction of the arrow.
- Temperature of the primary conductor should not exceed 100°C.
- Dynamic performances ( $di/dt$  and response time) are best with a single bar completely filling the primary hole.
- This is a standard model. For different versions (supply voltages, turns ratios, unidirectional measurements...), please contact us.