

Pressure & Temperature Combination Sensor



Thermometrics Pressure & Temperature Combination Sensor provides both pressure and temperature measurements in one sensor assembly. For reliable and accurate measurements, the sensor utilizes NTC thermistor technology for temperature sensing alongside silicon-based Microelectromechanical Systems (MEMS) technology for absolute pressure sensing. This sensor assembly also features robust internal circuit protection and sealed integral connection system, which makes it ideal for automotive, heavy equipment, agricultural, electric vehicle, and generator set applications.

Applications

- Automotive:
 - Engine Fuel
 - Engine Oil
 - Engine Intake Manifold
- Electric Vehicle (EV) Battery Coolant
- Generator Set

Features

- Robust internal circuit protection
- Sealed integral connection system
- MEMS based pressure sensing
- NTC thermistor temperature sensing
- Mating port per ISO standard
- Other thread sizes available per request
- Additional R vs. T and pressure curves available per request

Part Number	Mating Port Size	Installation Torque	Absolute Pressure Sensing Range	Housing Material	Mating Connector (Tyco P/N)
GE-2098	M14x1.5	25Nm \pm 5Nm	20 to 204 kPa (2.9 to 29.6 psi)	304 SS	776487-1
GE-2096	M14x1.5	25Nm \pm 5Nm	50 to 550 kPa (7.3 to 79.8 psi)	3600 Brass	776487-3
GE-2099	M12x1.5	15Nm \pm 5Nm	76 to 655 kPa (11.0 to 95.0 psi)	3600 Brass	776487-4

Performance Specifications

Electrical Performance

Parameter	Min	Typical	Max	Unit
Supply (Vs)	4.5	5	5.5	V
Current Consumption		7	10	mA

Pressure Performance

Parameter	Min	Typical	Max	Unit
Pressure Output (Ratio-metric to Supply)		Analog Output		V
Pressure Accuracy			±1	%
Operating Pressure Range ¹	0.2		6.55	Bar
Proof Pressure ²			22.5	Bar
Burst Pressure ²			50	Bar

1. Calibration range
2. Gauge Pressure

Part Number	Pressure Transfer Function	Pressure Range
GE-2098	$V_o = ((P \times 0.0045726) - 0.011453) \times V_s$	$20 < P < 203.7 \text{ kPaA}$
GE-2096	$V_o = ((P \times 0.00168) - 0.00040) \times V_s$	$50 < P < 550 \text{ kPaA}$
GE-2099	$V_o = ((P \times 0.0014496) - 0.030304) \times V_s$	$76.09 < P < 655.56 \text{ kPaA}$

Note: V_o = Voltage Output (V), V_s = Supply Voltage (V), P = Pressure (kPaA)

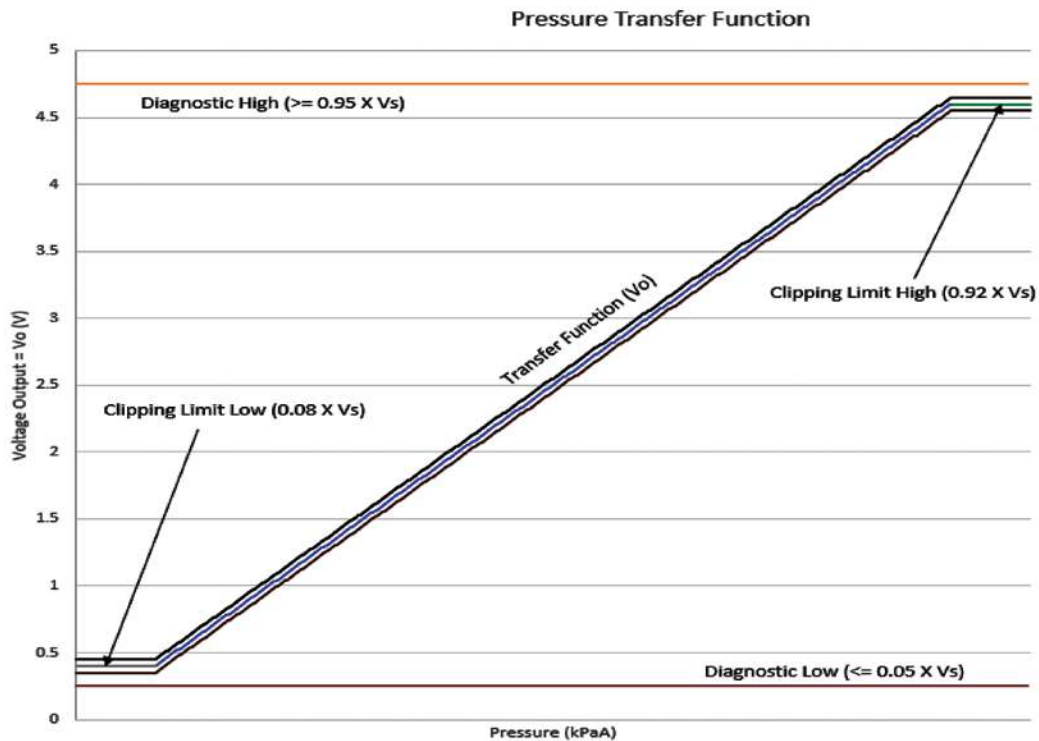

Performance Specifications (cont.)

Temperature Performance

Parameter	Min	Typical	Max	Unit
Storage Temperature	-40		+160	°C
Operating Temperature	-40		+135	°C
Temperature Output ¹	NTC, 3000Ω @ 25°C see table 1			Ω
Temperature Accuracy	See Table 1			°C
Temperature Time Response	< 24 in 6M/s air flow			Seconds

1. Parallel 0.047 μF capacitor for EMI protection see figure 1.

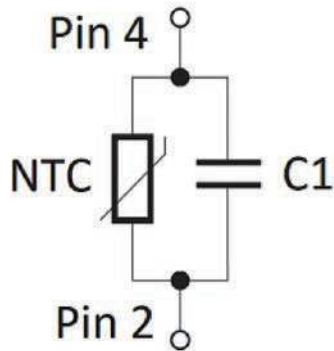

Figure 1: NTC Circuitry

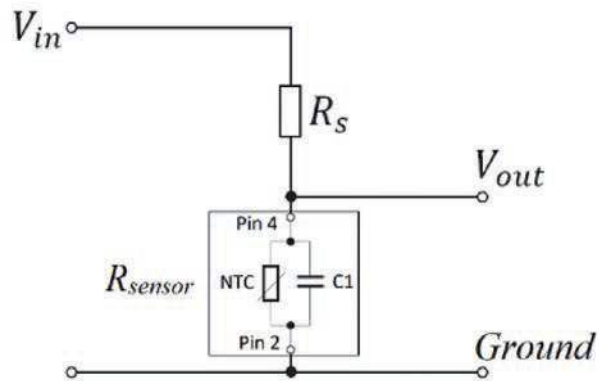

Figure 2: Typical NTC Application Circuit

Table 1: NTC thermistor - Resistance vs. Temperature			
Temp. (°C)	Resistance (Ω)	Resistance Tol. (±%)	Temp. Tol. (±°C)
-40	100950	3.0	0.45
-20	29121	2.6	0.45
-10	16599	2.4	0.44
0	9795	2.2	0.43
10	5970	2.1	0.44
25	3000	1.9	0.43
40	1598	1.7	0.42
50	1081	1.5	0.39
60	746.4	1.4	0.39
80	377.4	1.2	0.37
85	321.7	1.2	0.38
100	204.0	1.0	0.34
125	102.5	1.3	0.50
150	55.59	1.4	0.60

Performance Specifications (cont.)

Protection and Diagnostics

Parameter	
Overvoltage/ Reverse Voltage Protection	±40 VDC
Short Circuit Protection	Yes
Transient Voltage Suppression	Yes
Electrostatic Discharge (ESD) Protection	±8 kV contact, ±15 kV Air
Internal Failure Management System	<ul style="list-style-type: none"> • Application and firmware monitors • Programmable temperature thresholds • Sensor short and connection monitors • Programmable diagnostic levels • Sensors aging check

Mechanical Specifications

Weight

Stainless Steel: ~48.6g
 Machined Brass: ~46g

Mating Port Configuration

ISO-6149-1

Mating Port O-Ring Material

FKM 90 Durometer

Mating Connector Series

Tyco AMPSEAL 16

Mechanical Dimensions

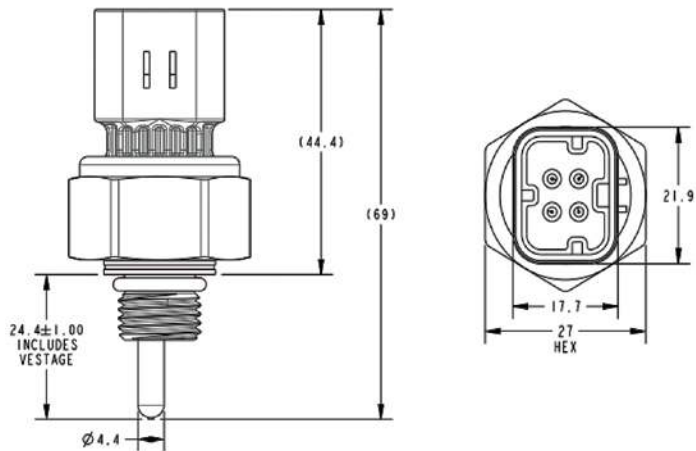

Connector Pinout

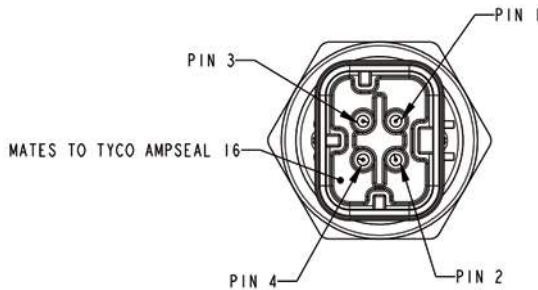

Pin 1: Supply Voltage

Pin 2: Ground

Pin 3: Pressure Output

Pin 4: Temperature Output