

PART NUMBER	REV	TERMINATOR	FEED TYPE	DESCRIPTION
1528909-1	A	LEADMAKER	MECH POST FEED	CUTS CARRIER
1528909-2	A	BENCH	MECH PRE FEED	CUTS CARRIER
1528909-6	A	LEADMAKER	MECH POST FEED	CONTINUOUS CARRIER
7-1528909-1	A	LEADMAKER	MECH POST FEED	-1 AND SPARE PARTS
7-1528909-2	A	BENCH	MECH PRE FEED	-2 AND SPARE PARTS
7-1528909-6	A	LEADMAKER	MECH POST FEED	-6 AND SPARE PARTS
7-1528909-7	A	-	-	SPARE PARTS KIT

CRIMP	SIZE	TYPE	RANGE
WIRE	2.40 [1.094 IN]	F	0.85mm ² -2.00mm ²
INSUL	3.00 [1.118 IN]	OV	1.80-2.70 [1.071-1.106 IN]
WIRE STRIP LENGTH 4.50-5.50 [1.177-1.216 IN]		APPL INSTRUCTIONS 408-8322 & 408-8490	
TERMINAL APPL SPEC	CR067-02	FEED	10.90 [4.429 IN]

TE PN	MANUF'S PN		
1642333-1	MT091-77280	-	-
-	-	-	-
-	-	-	-
-	-	-	-

WIRE SIZE	CRIMP HEIGHT	REF SETTING
2.00mm ²	1.70 ± 0.05 [1.067 ± 0.002 IN]	B8
1.50mm ²	1.63 ± 0.05 [1.064 ± 0.002 IN]	C4
1.25mm ²	1.60 ± 0.05 [1.063 ± 0.002 IN]	C6
1.00mm ²	1.41 ± 0.05 [1.056 ± 0.002 IN]	E0
0.85mm ²	1.30 ± 0.05 [1.051 ± 0.002 IN]	E7

- △ RECOMMENDED SPARE PARTS.
- 2. GREASE RAM, CAM, CAM FOLLOWER AND FEED ROD LIGHTLY.
- △ CERTAIN TERMINALS REQUIRE LUBRICATION. REFER TO THE APPLICATOR INSTRUCTION SHEET FOR MORE INFORMATION.
- 4. LUBRICATE DAILY PER THE APPLICATOR INSTRUCTION SHEET SUPPLIED WITH THE APPLICATOR.
- △ ALL CRIMP DATA SUPPLIED BY THE TERMINAL MANUFACTURER, APART FROM CRIMP HT'S FOR 1.00MMSQ & 1.50MMSQ WIRES WHICH HAVE BEEN CALCULATED BY TYCO ELECTRONICS UK LTD, BASED ON TERM MANUFACTURER'S DATA.
- △ REFER TO MITSUBISHI SPEC FOR ACTUAL WIRE TYPES.
- △ THIS APPLICATOR HAS BEEN DESIGNED TO APPLY WIRES WITH AVSS TYPE INSULATION.

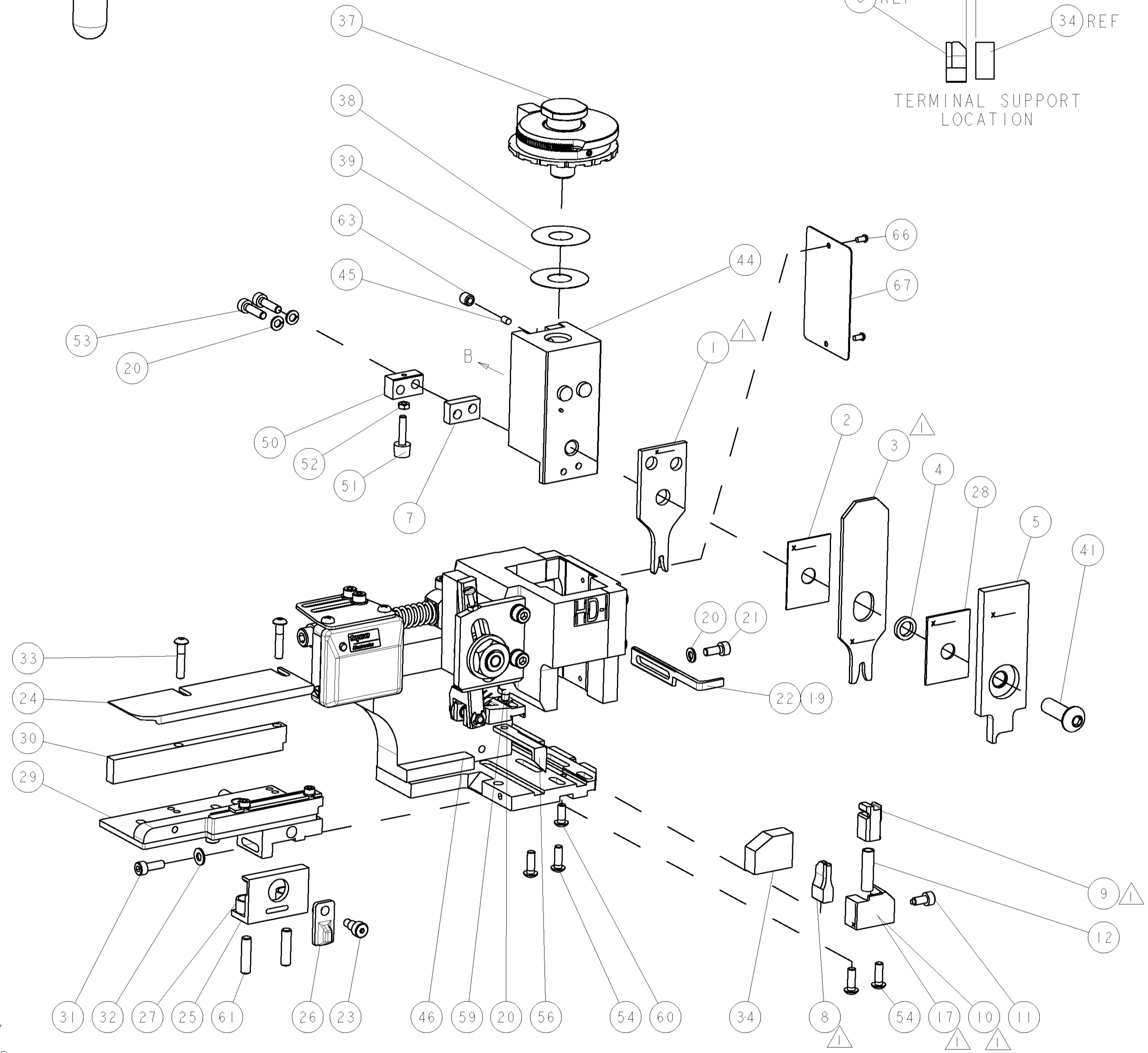
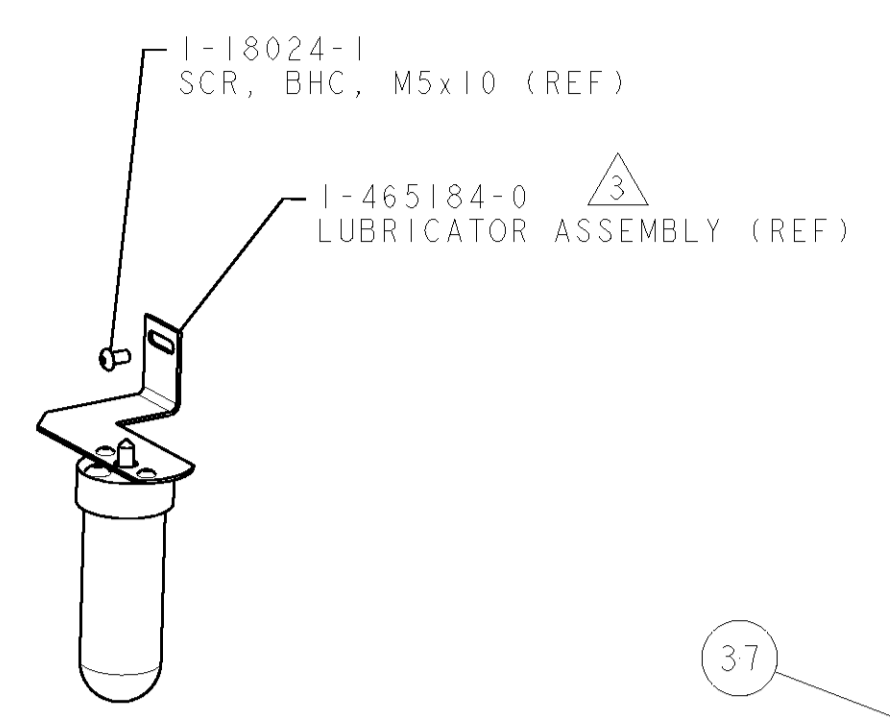
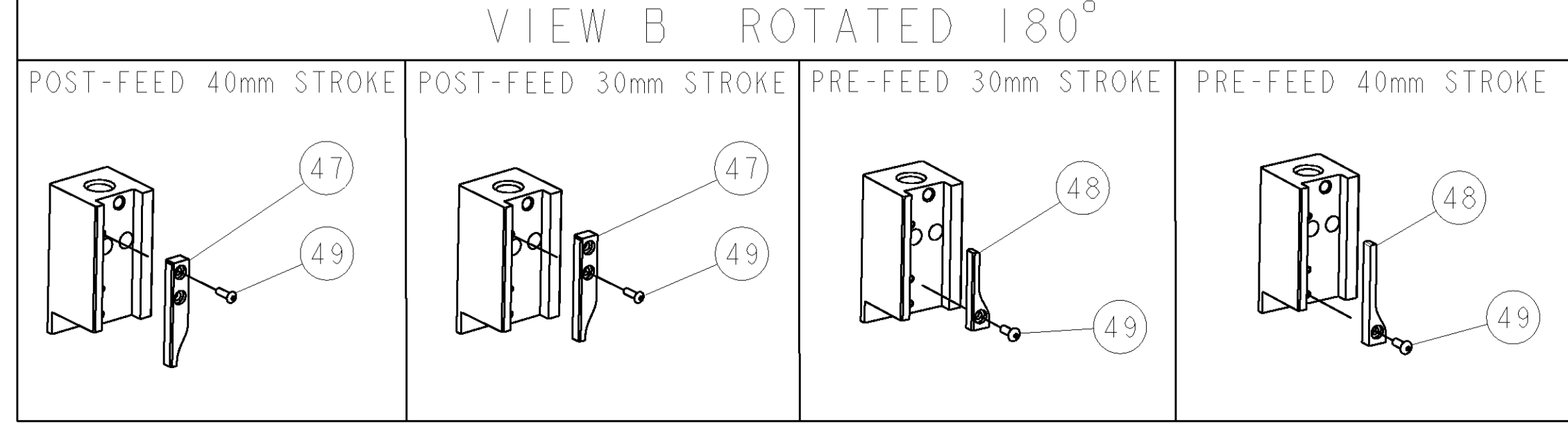

* WARNING
ON INSTALLATION, SET WIRE DISC TO LARGEST WIRE SIZE SETTING. USE OF SETTINGS BELOW MIN. REQUIRED CRIMP HEIGHT SETTING WILL CAUSE DAMAGE TO CRIMP TOOLING.

ITEM NO	DESCRIPTION	ITEM NO
84		
83		
82		
81		
80		
79		
78		
77		
76		
75		
74		
ITEM NO	DESCRIPTION	ITEM NO
-77		
-76		
-72		
-71		
-6		
-2		
-1		

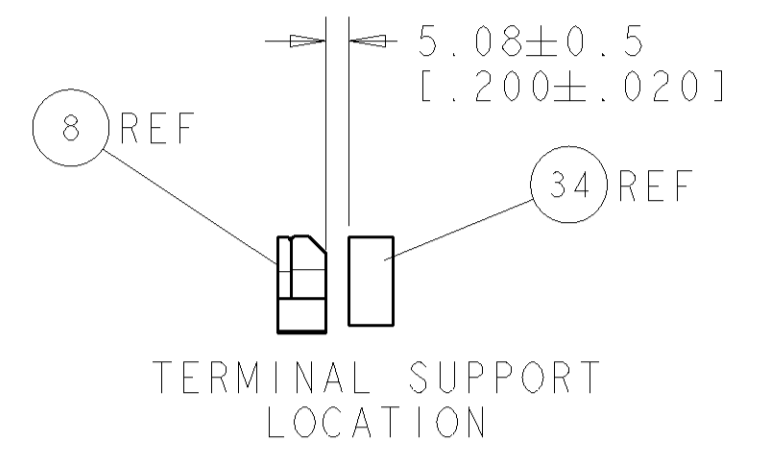
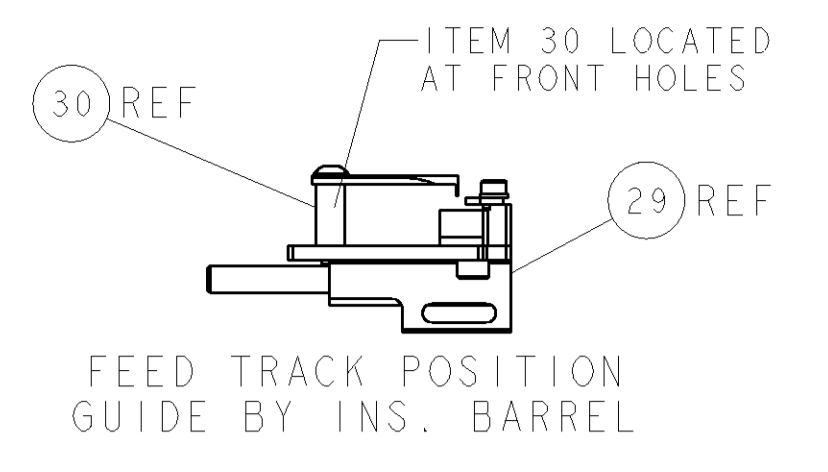

SET UP GAGE 458637-3		LOC	DIST	REVISIONS			
A	66			REV	DATE	BY	APPD
				A	ECO-08-022896	15SEP2008	MB MC

ITEM NO	DESCRIPTION	ITEM NO
73		
72		
71	DOCUMENTATION PACKAGE	
70		
69		
68		
67	PLATE, IDENTIFICATION	
66	SCREW, DRIVE	
65		
64		
63	SCR, SET, CUP POINT M6 X 6.0	
62		
61	SCR, SET, FLT POINT M5 X 20.0	
60	SCR, BTN SKT HD CAP (M4 X 10.0)	
59	SCR, HEX HD CAP M4 X 8.0	
58		
57		
56	PAWL, FEED	
55		
54	SCR, BTN SKT HD CAP (M4 X 12.0)	
53	SCR, SKT HD CAP M4 X 16.0	
52	NUT, HEX, REG M3	
51	BUMPER, HOLD DOWN	
50	SPACER, TONKER	
49	SCR, BTN SKT HD CAP (M3 X 10.0)	
48	CAM, UNIVERSAL PRE FEED	
47	CAM, UNIVERSAL POST-FEED	
46	APPLICATOR SUBASSEMBLY, HDI	
45	PLUG, NYLON	
44	RAM	
43		
42		
41	SCR, BTN SKT HD CAP (M8 X 25.0)	
40		
39	SHIM SUB-ASSY	
38	SHIM	
37	FINE ADJUST HEAD ASSEMBLY	
36		
35		
34	SUPPORT, TERMINAL	
33	SCR, BTN SKT HD CAP (M4 X 20.0)	
32	WASHER, FLAT, REG M4	
31	SCR, SKT HD CAP M4 X 12.0	
30	SPACER, STRIP GUIDE	
29	STRIP GUIDE ASSEMBLY	
28	SPACER, CRIMPER	
27	SPRING, COMPRESSION	
26	LEVER, DRAG RELEASE	
25	DRAG, TERMINAL	
24	PLATE, STRIP GUIDE	
23	SCR, SKT HD SHLDR 5.0 DIA X 6.0	
22	STRIPPER	
21	SCR, SKT HD CAP M4 X 10.0	
20	WASHER, SPRG LOCK, REG M4	
19	STRIPPER	
18		
17	SHEAR HOLDER, FRONT	
16		
15		
14		
13		
12	SPRING, COMPRESSION	
11	STOP, SHEAR	
10	SHEAR HOLDER, FRONT, CUT	
9	FLOATING SHEAR, FRONT	
8	ANVIL, COMBINATION	
7	SPACER	
6		
5	DEPRESSOR, SHEAR	
4	BLOCK, CRIMPER SPACER	
3	CRIMPER, INSULATION OVERLAP	
2	SPACER, CRIMPER	
1	CRIMPER, WIRE	

ITEM NO	DESCRIPTION	ITEM NO
-77		
-76		
-72		
-71		
-6		
-2		
-1		

ITEM NO	DESCRIPTION	ITEM NO
84		
83		
82		
81		
80		
79		
78		
77		
76		
75		
74		
ITEM NO	DESCRIPTION	ITEM NO
-77		
-76		
-72		
-71		
-6		
-2		
-1		