

TYPE 1 类型 1

Single PG/M thread
单个 PG/M 螺纹孔

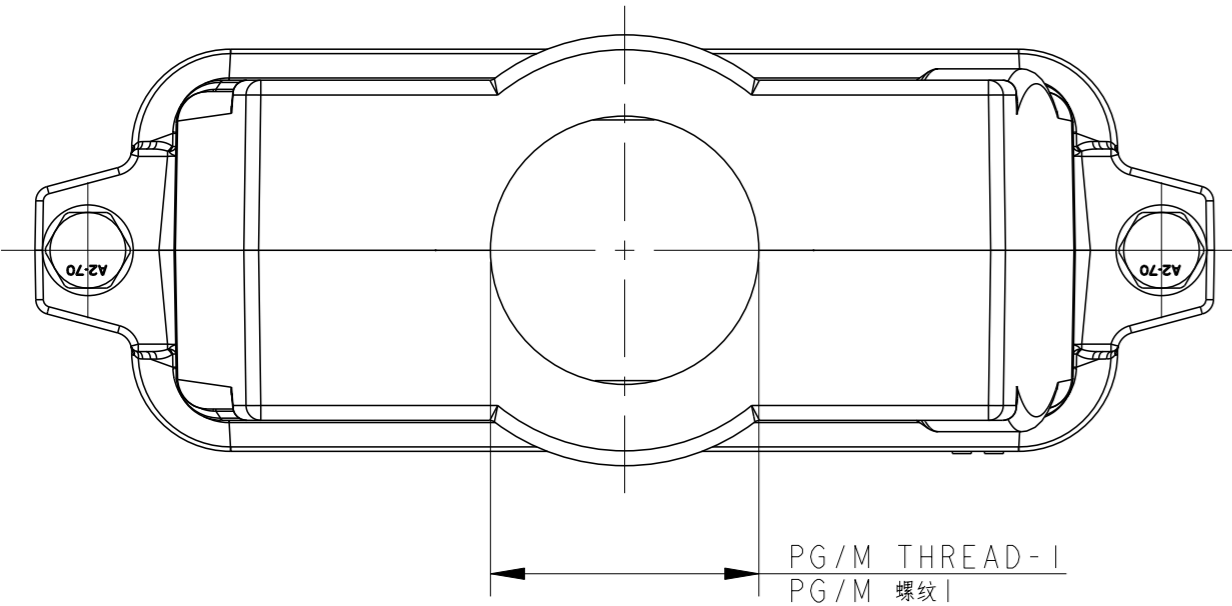

PG/M THREAD-1
PG/M 螺纹1

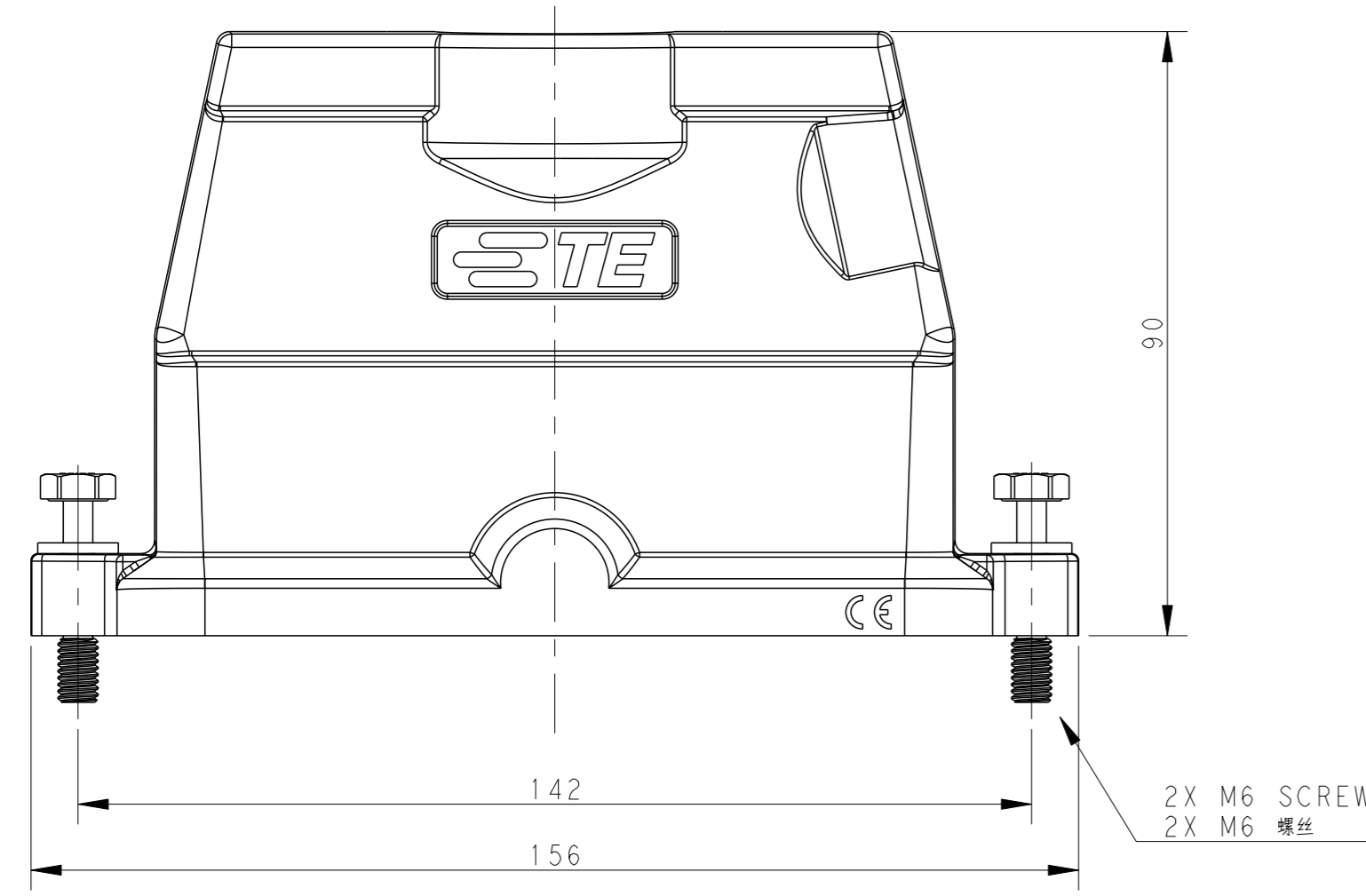

2X M6 SCREW
2X M6 螺丝

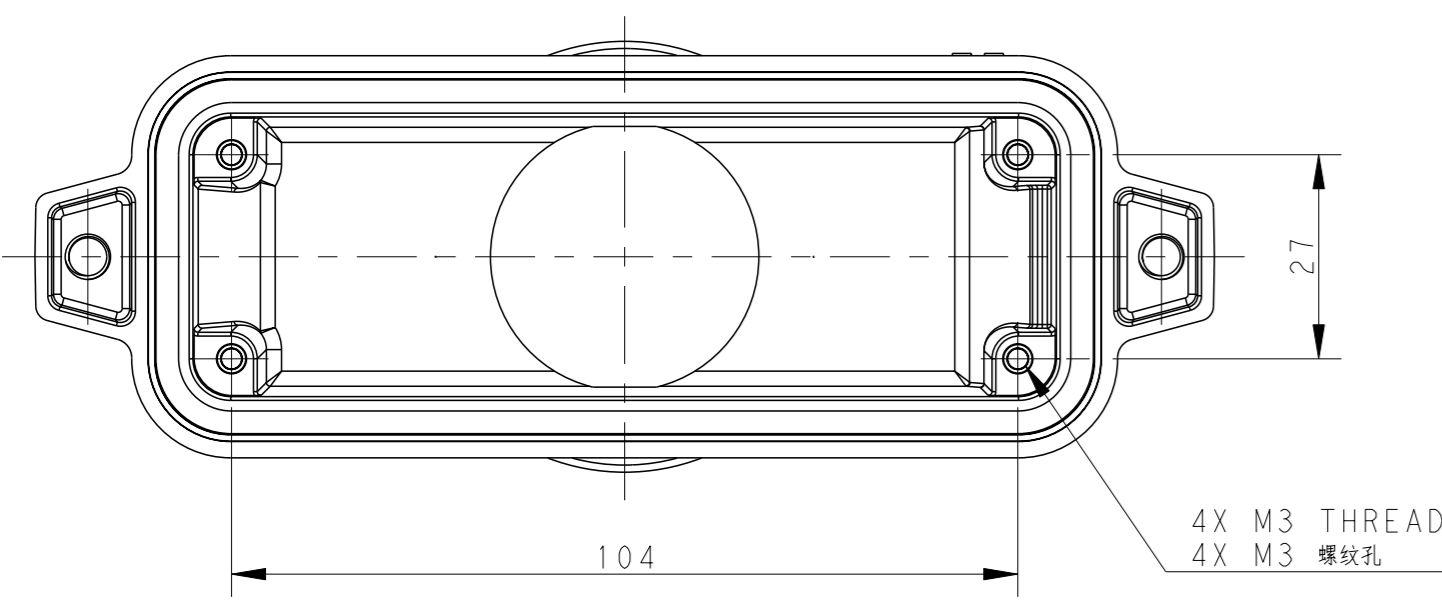

4X M3 THREAD
4X M3 螺纹孔

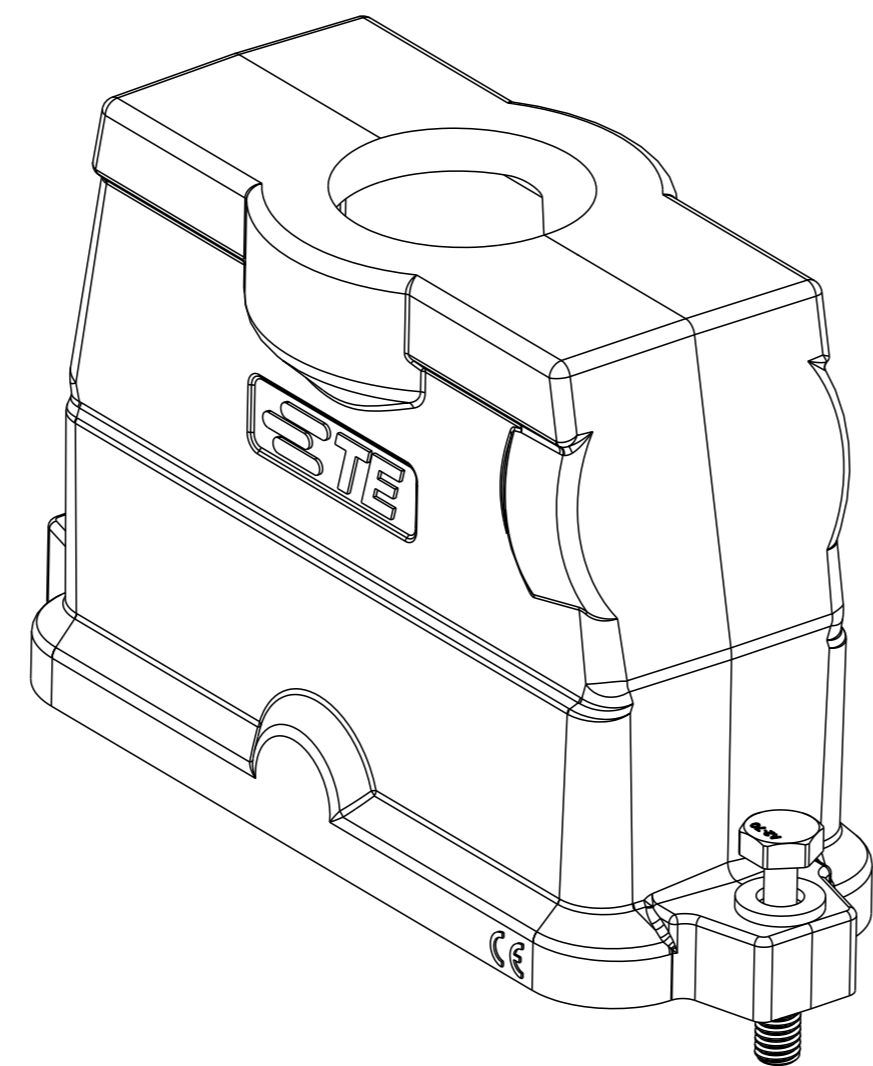
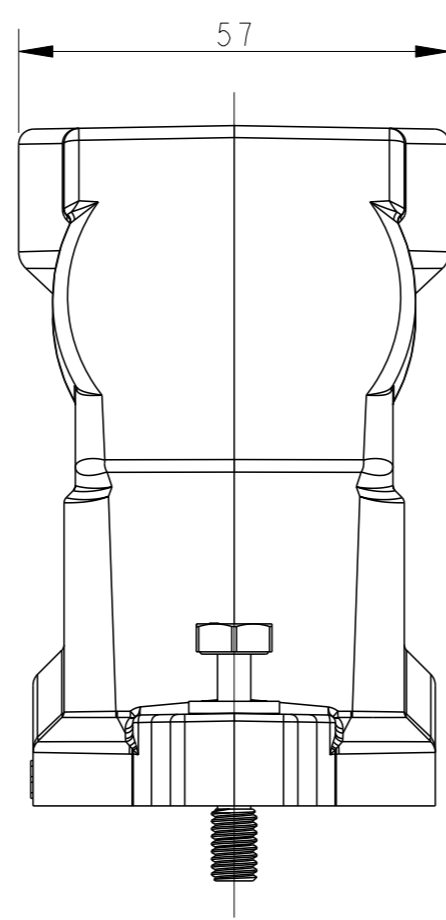

TYPE 2 类型 2

Two PG/M threads
两个 PG/M 螺纹孔

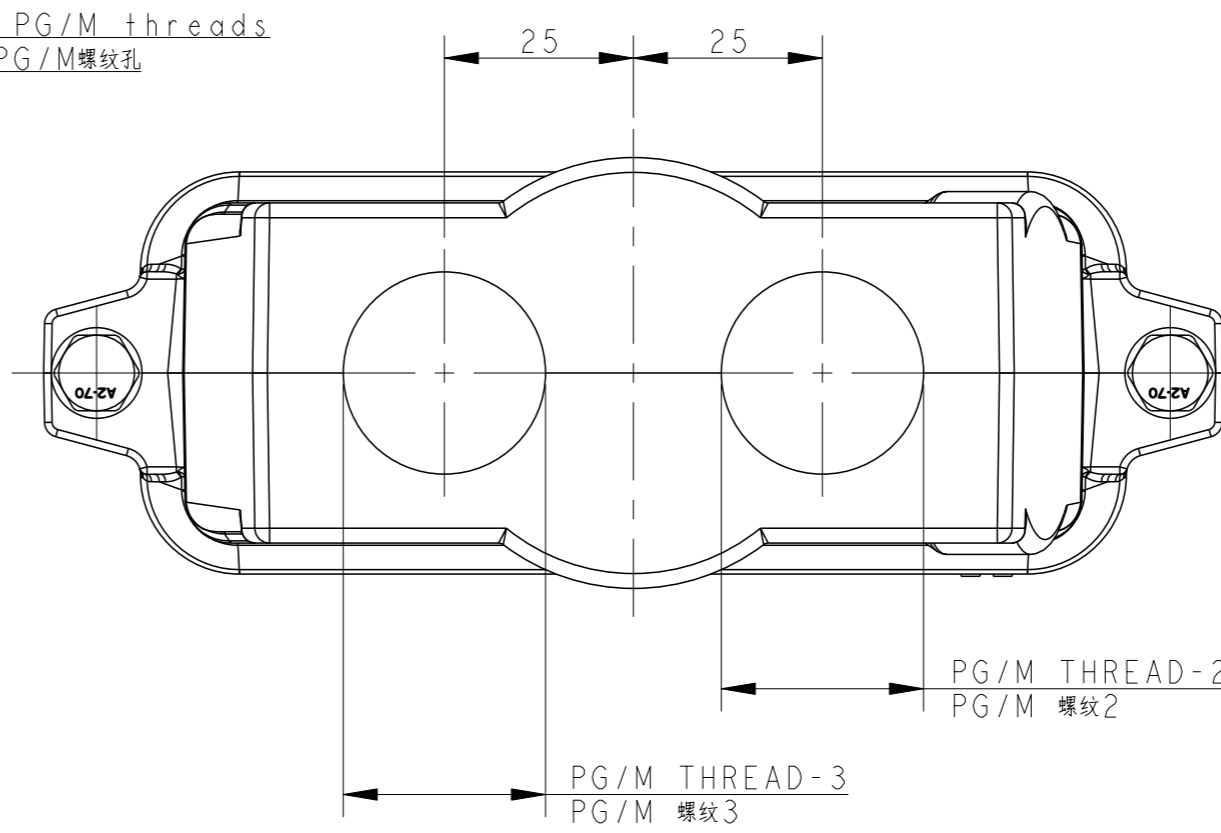

PG/M THREAD-2
PG/M 螺纹2

PG/M THREAD-3
PG/M 螺纹3

All dimension is same as TYPE 1, except those defined in this TYPE
除了在本类型中定义的尺寸外, 其他尺寸同类型 1

TYPE 3 类型 3

Three PG/M threads
三个 PG/M 螺纹孔

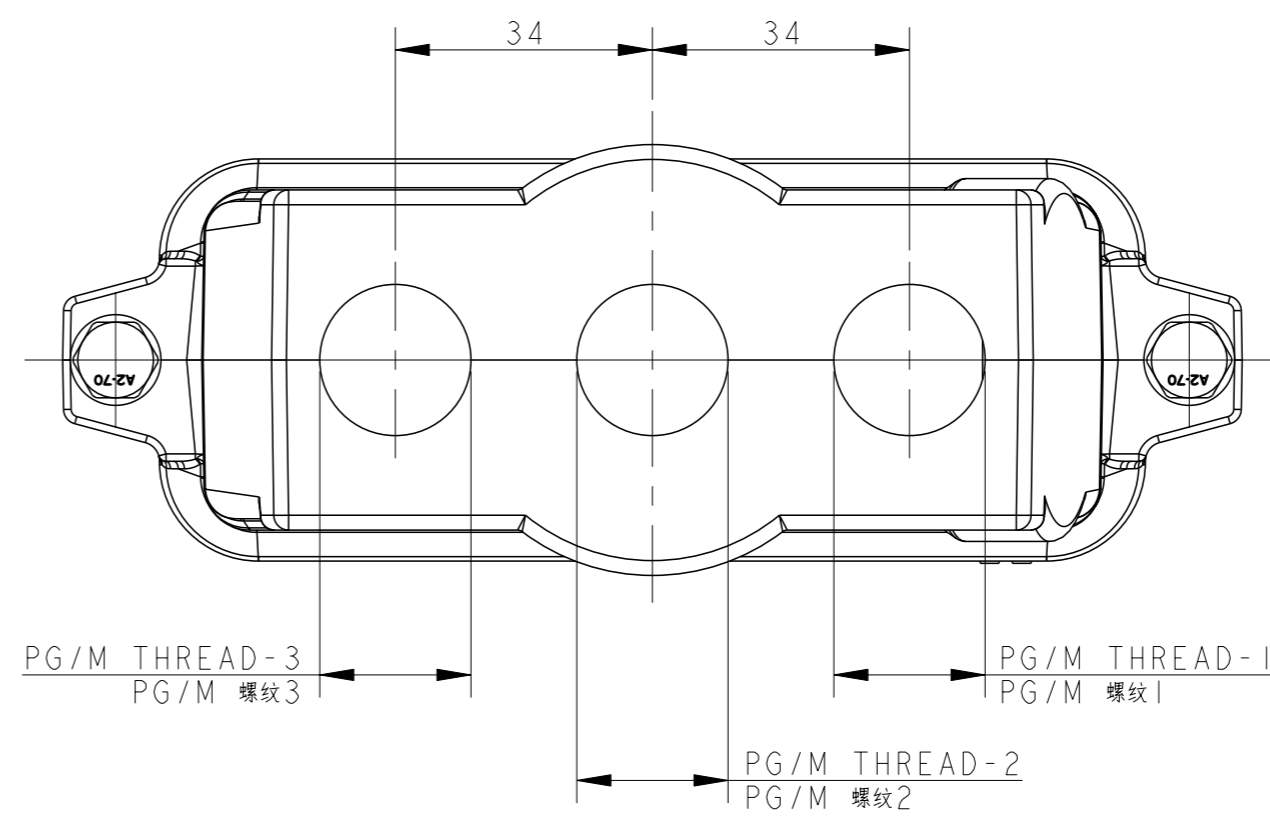

PG/M THREAD-1
PG/M 螺纹1

PG/M THREAD-2
PG/M 螺纹2

PG/M THREAD-3
PG/M 螺纹3

All dimension is same as TYPE 1, except those defined in this TYPE
除了在本类型中定义的尺寸外, 其他尺寸同类型 1

REVISIONS				
#	LY#	DESCRIPTION	DATE	APVD
A		INITIAL RELEASE	07JUN2016	DW CW
A1		ECR-17-018159	13DEC2017	RL CW
A2		ECR-18-012258	01AUG2018	DW CW
B		ECR-20-016312	03JUN2021	BS CW

NOTES:
1. TECHNICAL CHARACTERISTICS:
HOOD MATERIAL: DIE CAST ALUMINIUM ALLOY
SURFACE TREATMENT: SEE TABLE
DEGREE OF PROTECTION: IP68 (MATED)

注释:
1. 技术参数:
壳体材料: 铝合金
表面处理: 见表格
防护等级: IP68 (配合)

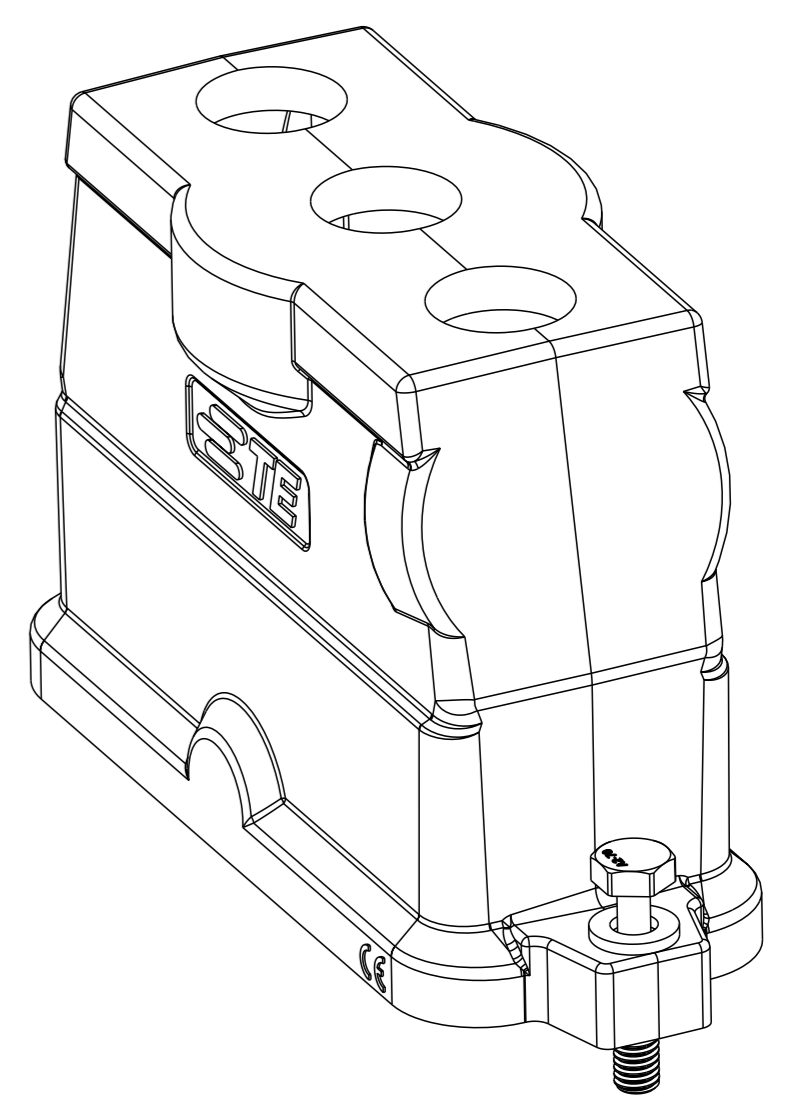
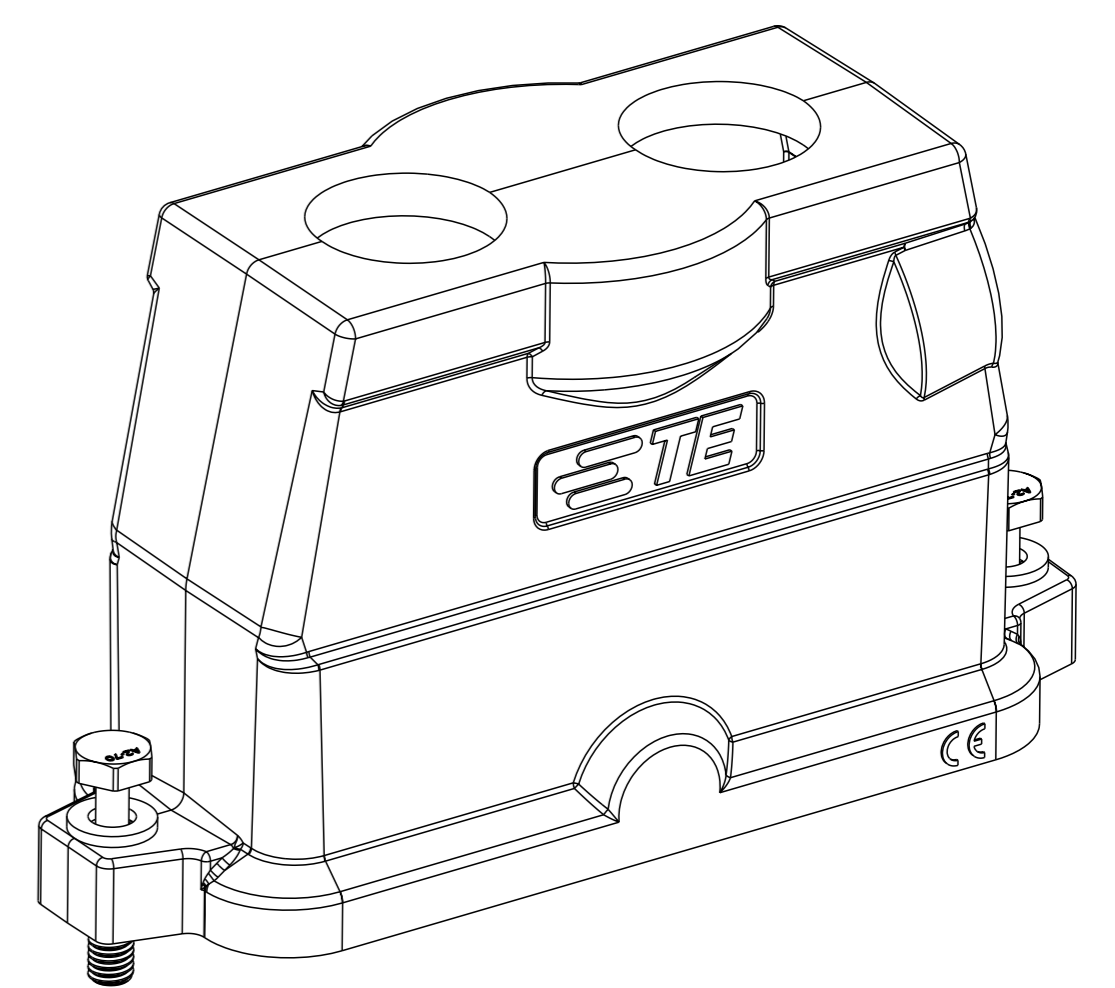

THIS DRAWING IS A CONTROLLED DOCUMENT.		OWN: DAVID WANG 07JUN2016	TE Connectivity NAME: H24BPR-TGHC-PG/M-EMC-C
DIMENSIONS: mm		CHK: CHRIS WANG 07JUN2016	
TOLERANCES UNLESS OTHERWISE SPECIFIED:		APVD: XIANG XU 07JUN2016	SIZE: A1
0 PLC ±	1 PLC ±	PRODUCT SPEC	CAGE CODE: -
2 PLC ±	3 PLC ±	APPLICATION SPEC	DRAWING NO: C-T192224XXXXX09
4 PLC ±	ANGLES ±	FINISH	RESTRICTED TO: 1 OF 2
MATERIAL: -	FINISH: -	WEIGHT: -	SCALE: 1:1
CUSTOMER DRAWING		DATE: 07JUN2016	REV: B

THIS DRAWING IS UNPUBLISHED. RELEASED FOR PUBLICATION 20
 © COPYRIGHT 20 BY - ALL RIGHTS RESERVED.

REVISIONS				
#	LY#	DESCRIPTION	DATE	OWN APVD
-	-	SEE SHEET 1	-	-

NOTES:
SEE SHEET 1

PART NUMBER	料号	DESCRIPTION	描述	PG/M THREAD-3	PG/M 螺纹3	PG/M THREAD-2	PG/M 螺纹2	PG/M THREAD-1	PG/M 螺纹1	TYPE	类型
T1922240320-009	H24BPR-TGHC-3M20-EMC-C	H24BPR HOOD,CENTER LOCKING, TOP ENTRY 3M20,BLACK H24BPR上壳,中部锁定,顶出3M20,黑色		M20	M20	M20				TYPE 3	类型3
T1922241221-009	H24BPR-TGHC-2PG21-EMC-C	H24BPR HOOD,CENTER LOCKING, TOP ENTRY 2PG21,SILVER WHITE H24BPR上壳,中部锁定,顶出2PG21,银白色		PG21	PG21	-				TYPE 2	类型2
T1922242150-009	H24BPR-TGHC- M50-EMC-C	H24BPR HOOD,CENTER LOCKING, TOP ENTRY M50,GREY H24BPR上壳,中部锁定,顶出M50,灰色		-	-	M50				TYPE 1	类型1
T1922241140-009	H24BPR-TGHC-M40-EMC-C	H24BPR HOOD,CENTER LOCKING, TOP ENTRY M40,SILVER WHITE H24BPR上壳,中部锁定,顶出M40,银白色		-	-	M40					
T1922241136-009	H24BPR-TGHC-PG36-EMC-C	H24BPR HOOD,CENTER LOCKING, TOP ENTRY PG36,SILVER WHITE H24BPR上壳,中部锁定,顶出PG36,银白色		-	-	PG36					
T1922241132-009	H24BPR-TGHC-M32-EMC-C	H24BPR HOOD,CENTER LOCKING, TOP ENTRY M32,SILVER WHITE H24BPR上壳,中部锁定,顶出M32,银白色		-	-	M32					
T1922241129-009	H24BPR-TGHC-PG29-EMC-C	H24BPR HOOD,CENTER LOCKING, TOP ENTRY PG29,SILVER WHITE H24BPR上壳,中部锁定,顶出PG29,银白色		-	-	PG29					
T1922241125-009	H24BPR-TGHC-M25-EMC-C	H24BPR HOOD,CENTER LOCKING, TOP ENTRY M25,SILVER WHITE H24BPR上壳,中部锁定,顶出M25,银白色		-	-	M25					
T1922241121-009	H24BPR-TGHC-PG21-EMC-C	H24BPR HOOD,CENTER LOCKING, TOP ENTRY PG21,SILVER WHITE H24BPR上壳,中部锁定,顶出PG21,银白色		-	-	PG21					
T1922240140-009	H24BPR-TGHC-M40-EMC-C	H24BPR HOOD,CENTER LOCKING, TOP ENTRY M40,BLACK H24BPR上壳,中部锁定,顶出M40,黑色		-	-	M40					
T1922240136-009	H24BPR-TGHC-PG36-EMC-C	H24BPR HOOD,CENTER LOCKING, TOP ENTRY PG36,BLACK H24BPR上壳,中部锁定,顶出PG36,黑色		-	-	PG36					
T1922240132-009	H24BPR-TGHC-M32-EMC-C	H24BPR HOOD,CENTER LOCKING, TOP ENTRY M32,BLACK H24BPR上壳,中部锁定,顶出M32,黑色		-	-	M32					
T1922240129-009	H24BPR-TGHC-PG29-EMC-C	H24BPR HOOD,CENTER LOCKING, TOP ENTRY PG29,BLACK H24BPR上壳,中部锁定,顶出PG29,黑色		-	-	PG29					
T1922240125-009	H24BPR-TGHC-M25-EMC-C	H24BPR HOOD,CENTER LOCKING, TOP ENTRY M25,BLACK H24BPR上壳,中部锁定,顶出M25,黑色		-	-	M25					
T1922240121-009	H24BPR-TGHC-PG21-EMC-C	H24BPR HOOD,CENTER LOCKING, TOP ENTRY PG21,BLACK H24BPR上壳,中部锁定,顶出PG21,黑色		-	-	PG21					

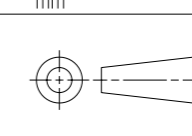
THIS DRAWING IS A CONTROLLED DOCUMENT. DIMENSIONS: mm		TOLERANCES UNLESS OTHERWISE SPECIFIED:		OWN: DAVID WANG 07JUN2016	 TE Connectivity
		0 PLC ± 1 PLC ± 2 PLC ± 3 PLC ± 4 PLC ± ANGLES ± FINISH -		CHK: CHRIS WANG 07JUN2016	
MATERIAL: -		FINISH: -		APVD: XIANG XU 07JUN2016	
CUSTOMER DRAWING		WEIGHT: -		NAME: H24BPR-TGHC-PG/M-EMC-C	
SCALE: 1:1		SHEET 2 OF 2		SIZE: A1 CAGE CODE: - DRAWING NO: T192224XXXXX09 RESTRICTED TO: B	

Printed on 8 Jun 2021 09:27 (China Standard Time) from T1922240320