

INSULATED GATE BIPOLAR TRANSISTOR WITH ULTRA-FAST SOFT RECOVERY DIODE

Features

- Low $V_{CE(ON)}$ Non Punch Through IGBT technology
- Low Diode V_F
- 10 μ s Short Circuit Capability
- Square RBSOA
- Ultra-soft Diode Reverse Recovery Characteristics
- Positive $V_{CE(ON)}$ temperature co-efficient
- Lead-free

Benefits

- Benchmark Efficiency for Motor Control
- Rugged transient performance for increased reliability
- Excellent current sharing in parallel operation
- Low EMI

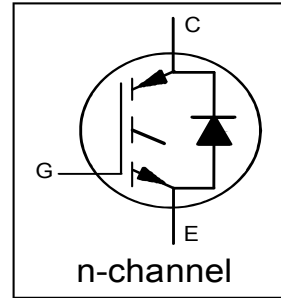

$V_{CES} = 600V$
$I_C = 3.7A, T_C = 100^\circ C$
$T_{J(MAX)} = 150^\circ C$
$V_{CE(ON)} \text{ typ.} = 1.95V$

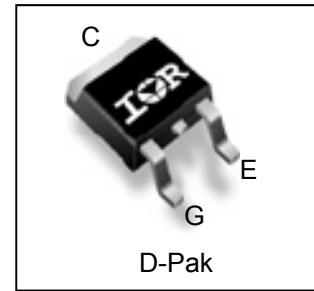

G	C	E
Gate	Collector	Emitter

Base part number	Package Type	Standard Pack		Orderable Part Number
		Form	Quantity	
IRGR2B60KDPbF	D-Pak	Tube	75	IRGR2B60KDPbF
		Tape and Reel	2000	IRGR2B60KDTRPbF
		Tape and Reel Left	3000	IRGR2B60KDTRLpbF
		Tape and Reel Right	3000	IRGR2B60KDTRRpBf

Absolute Maximum Ratings

	Parameter	Max.	Units
V_{CES}	Collector-to-Emitter Voltage	600	V
$I_C @ T_C = 25^\circ C$	Continuous Collector Current	6.3	A
$I_C @ T_C = 100^\circ C$	Continuous Collector Current	3.7	
I_{CM}	Pulse Collector Current, $V_{GE} = 15V$ ②⑤	8.0	
I_{LM}	Clamped Inductive Load Current, $V_{GE} = 20V$ ①	8.0	
$I_F @ T_C = 25^\circ C$	Diode Continuous Forward Current	6.3	
$I_F @ T_C = 100^\circ C$	Diode Continuous Forward Current	3.7	
I_{FM}	Diode Maximum Forward Current ②	8.0	
V_{GE}	Continuous Gate-to-Emitter Voltage	± 20	V
$P_D @ T_C = 25^\circ C$	Maximum Power Dissipation	35	W
$P_D @ T_C = 100^\circ C$	Maximum Power Dissipation	14	
T_J T_{STG}	Operating Junction and Storage Temperature Range	-55 to +150	$^\circ C$
	Soldering Temperature, for 10 sec.	300 (0.063 in.(1.6mm) from case)	

Thermal Resistance

	Parameter	Min.	Typ.	Max.	Units
$R_{\theta JC}$ (IGBT)	Junction-to-Case (IGBT) ④	—	—	3.56	$^\circ C/W$
$R_{\theta JC}$ (Diode)	Junction-to-Case (Diode) ④	—	—	7.70	
$R_{\theta JA}$	Junction-to-Ambient (PCB Mount) ⑥	—	—	50	

Electrical Characteristics @ T_J = 25°C (unless otherwise specified)

	Parameter	Min.	Typ.	Max.	Units	Conditions
V _{(BR)CES}	Collector-to-Emitter Breakdown Voltage	600	—	—	V	V _{GE} = 0V, I _C = 500μA ③
ΔV _{(BR)CES} /ΔT _J	Temperature Coeff. of Breakdown Voltage	—	0.49	—	V/°C	V _{GE} = 0V, I _C = 1mA (25°C-150°C)
V _{CE(on)}	Collector-to-Emitter Saturation Voltage	—	1.95	2.25	V	I _C = 2.0A, V _{GE} = 15V, T _J = 25°C
		—	2.28	—		I _C = 2.0A, V _{GE} = 15V, T _J = 150°C
V _{GE(th)}	Gate Threshold Voltage	4.0	—	6.0	V	V _{CE} = V _{GE} , I _C = 250μA
g _{fe}	Forward Transconductance	—	1.2	—	S	V _{CE} = 50V, I _C = 2.0A, PW = 20μs
I _{CES}	Collector-to-Emitter Leakage Current	—	0.5	25	μA	V _{GE} = 0V, V _{CE} = 600V
		—	23	—		V _{GE} = 0V, V _{CE} = 600V, T _J = 150°C
V _{FM}	Diode Forward Voltage Drop	—	1.3	1.6	V	I _F = 2.0A
		—	1.1	—		I _F = 2.0A, T _J = 150°C
I _{GES}	Gate-to-Emitter Leakage Current	—	—	±100	nA	V _{GE} = ±20V

Switching Characteristics @ T_J = 25°C (unless otherwise specified)

	Parameter	Min.	Typ.	Max.	Units	Conditions
Q _g	Total Gate Charge (turn-on)	—	8.0	12	nC	I _C = 2.0A
Q _{ge}	Gate-to-Emitter Charge (turn-on)	—	1.3	2.0		V _{GE} = 15V
Q _{gc}	Gate-to-Collector Charge (turn-on)	—	4.0	6.0		V _{CC} = 400V
E _{on}	Turn-On Switching Loss	—	74	160	μJ	I _C = 2.0A, V _{CC} = 400V, V _{GE} = 15V R _G = 100Ω, L = 7.1mH, T _J = 25°C
E _{off}	Turn-Off Switching Loss	—	39	120		
E _{tot}	Total Switching Loss	—	113	280		
t _{d(on)}	Turn-On delay time	—	11	30	ns	Energy losses include tail & diode reverse recovery
t _r	Rise time	—	8.7	25		
t _{d(off)}	Turn-Off delay time	—	150	170		
t _f	Fall time	—	56	75		
E _{on}	Turn-On Switching Loss	—	120	—		
E _{off}	Turn-Off Switching Loss	—	68	—		
E _{tot}	Total Switching Loss	—	188	—		
t _{d(on)}	Turn-On delay time	—	13	—	ns	Energy losses include tail & diode reverse recovery
t _r	Rise time	—	6.8	—		
t _{d(off)}	Turn-Off delay time	—	170	—		
t _f	Fall time	—	110	—		
C _{ies}	Input Capacitance	—	110	—	pF	V _{GE} = 0V V _{CC} = 30V f = 1.0Mhz
C _{oes}	Output Capacitance	—	17	—		
C _{res}	Reverse Transfer Capacitance	—	4.0	—		
RBSOA	Reverse Bias Safe Operating Area	FULL SQUARE				T _J = 150°C, I _C = 8.0A V _{CC} = 480V, V _p ≤ 600V R _G = 100Ω, V _{GE} = +20V to 0V
SCSOA	Short Circuit Safe Operating Area	10	—	—	μs	T _J = 150°C, V _p ≤ 600V, R _G = 330Ω V _{CC} = 360V, V _{GE} = +15V to 0V
E _{rec}	Reverse Recovery Energy of the Diode	—	19	30	μJ	T _J = 150°C
t _{rr}	Diode Reverse Recovery Time	—	45	68	ns	V _{CC} = 400V, I _F = 2.0A, L = 7.1mH
I _{rr}	Diode Peak Reverse Recovery Current	—	5.8	8.7	A	V _{GE} = 15V, R _G = 100Ω

Notes:

- ① V_{CC} = 80% (V_{CES}), V_{GE} = 20V, L = 200μH, R_G = 100Ω.
- ② Pulse width limited by max. junction temperature.
- ③ Refer to AN-1086 for guidelines for measuring V_{(BR)CES} safely.
- ④ R_θ is measured at T_J of approximately 90°C.
- ⑤ FBSOA operating conditions only.
- ⑥ When mounted on 1" square PCB (FR-4 or G-10 Material). For recommended footprint and soldering techniques refer to application note #AN-994.

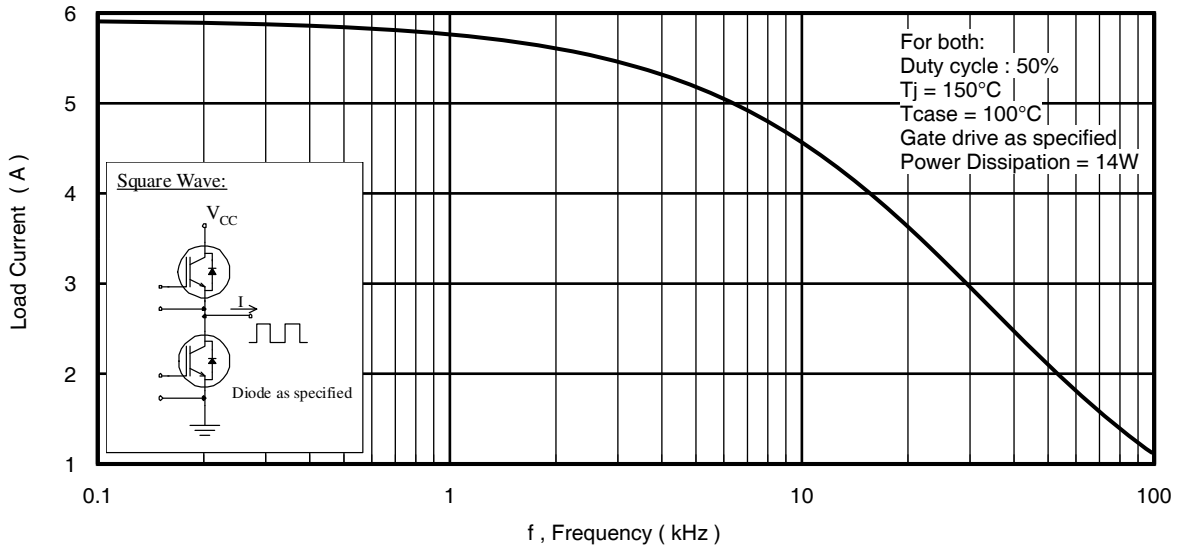

Fig. 1 - Typical Load Current vs. Frequency
(Load Current = I_{RMS} of fundamental)

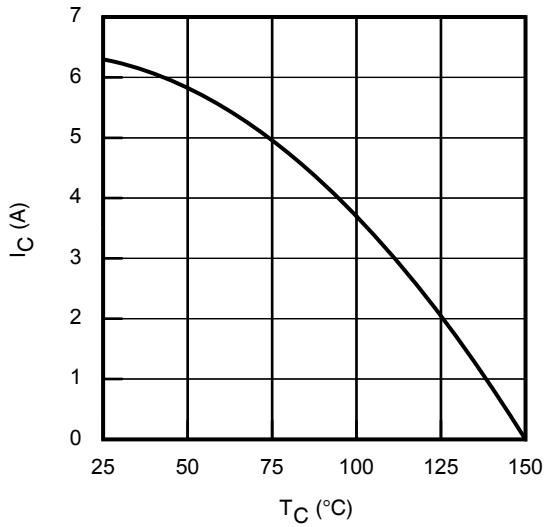

Fig. 2 - Maximum DC Collector Current vs. Case Temperature

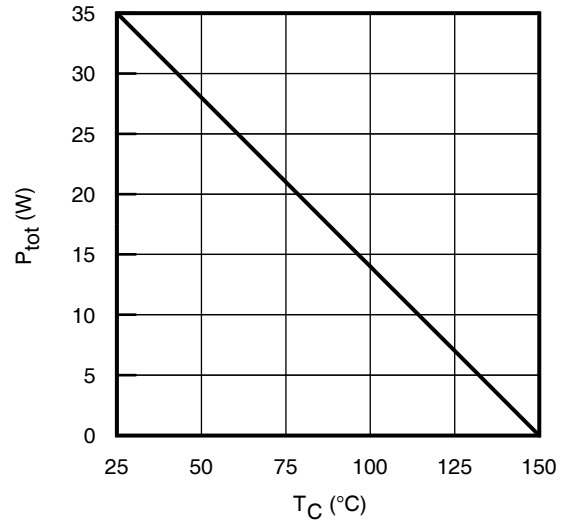

Fig. 3 - Power Dissipation vs. Case Temperature

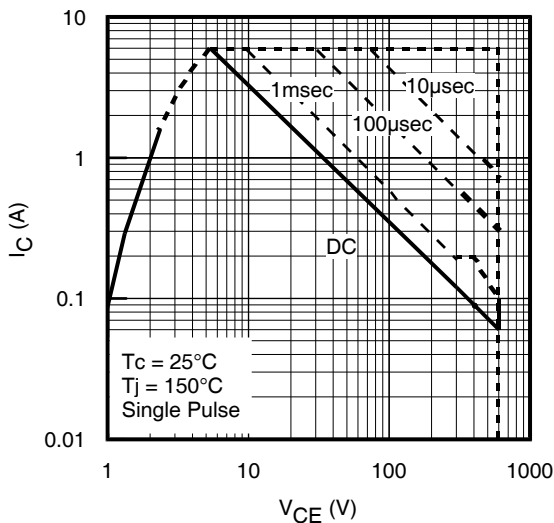

Fig. 4 - Forward SOA
 $T_c = 25^\circ\text{C}$; $T_j \leq 150^\circ\text{C}$; $V_{GE} = 15\text{V}$

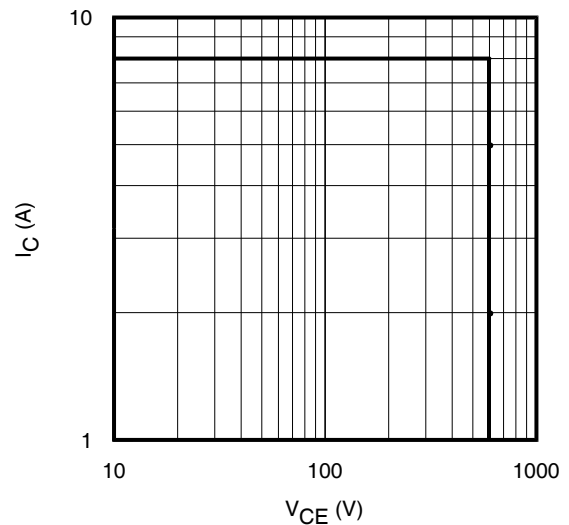

Fig. 5 - Reverse Bias SOA
 $T_j = 150^\circ\text{C}$; $V_{GE} = 20\text{V}$

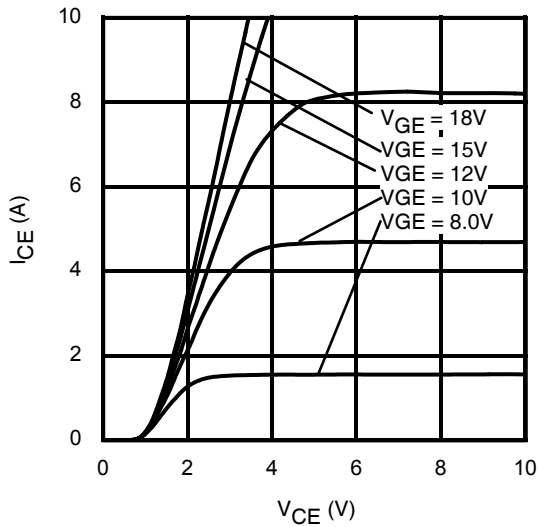

Fig. 6 - Typ. IGBT Output Characteristics
 $T_J = -40^\circ\text{C}$; $t_p = 20\mu\text{s}$

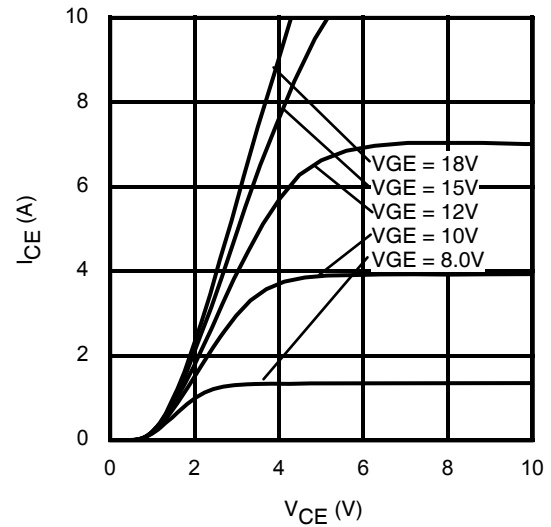

Fig. 7 - Typ. IGBT Output Characteristics
 $T_J = 25^\circ\text{C}$; $t_p = 20\mu\text{s}$

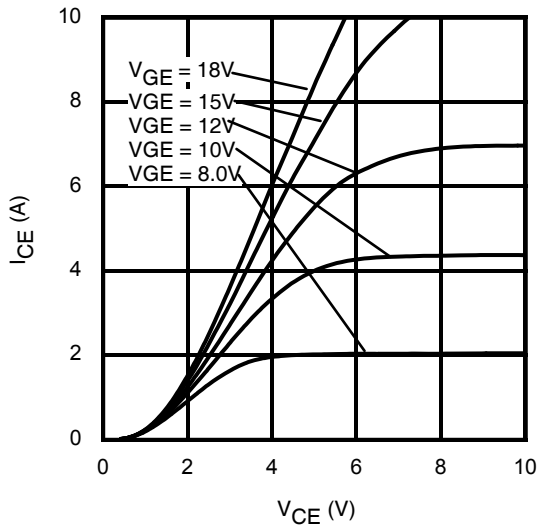

Fig. 8 - Typ. IGBT Output Characteristics
 $T_J = 150^\circ\text{C}$; $t_p = 20\mu\text{s}$

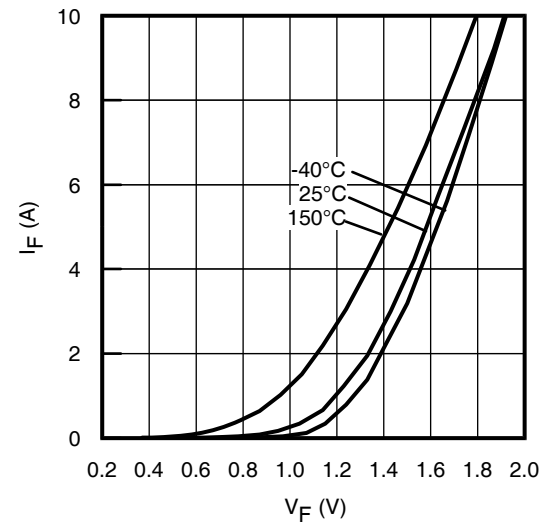

Fig. 9 - Typ. Diode Forward Voltage Drop Characteristics

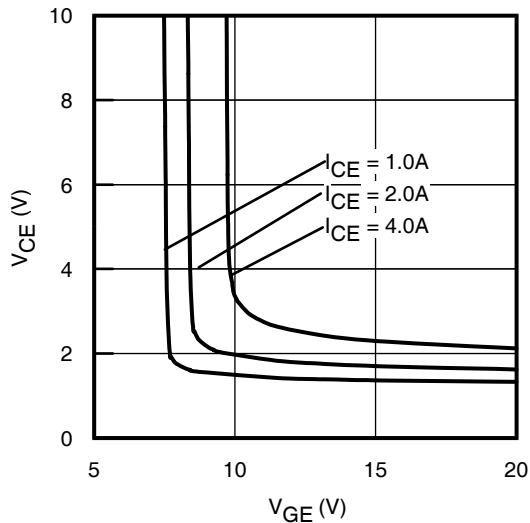

Fig. 10 - Typical V_{CE} vs. V_{GE}
 $T_J = -40^\circ\text{C}$

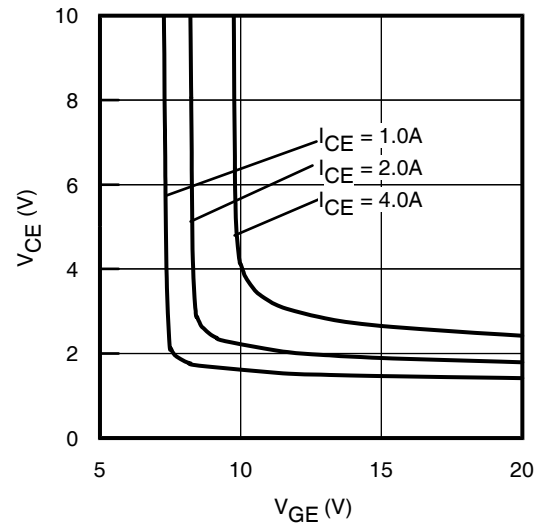

Fig. 11 - Typical V_{CE} vs. V_{GE}
 $T_J = 25^\circ\text{C}$

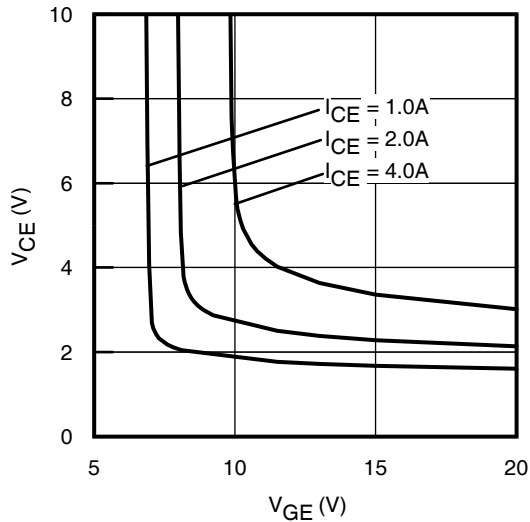

Fig. 12 - Typical V_{CE} vs. V_{GE}
 $T_J = 150^\circ\text{C}$

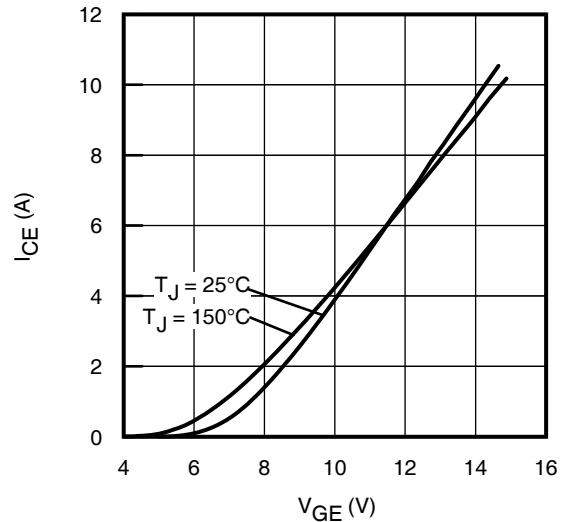

Fig. 13 - Typ. Transfer Characteristics
 $V_{CE} = 50\text{V}$; $t_p = 20\mu\text{s}$

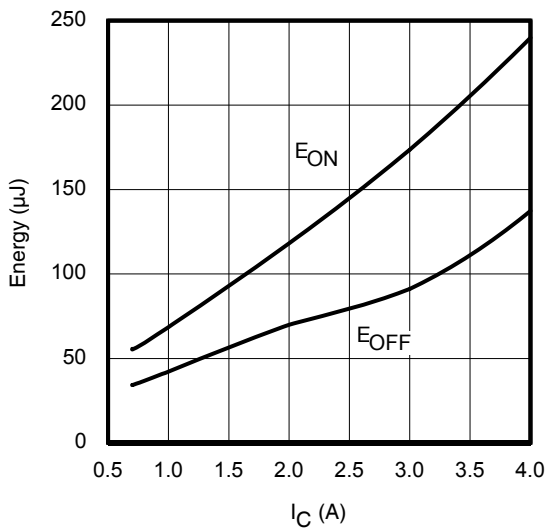

Fig. 14 - Typ. Energy Loss vs. I_C

$T_J = 150^\circ\text{C}$; $L = 7.1\text{mH}$; $V_{CE} = 400\text{V}$; $R_G = 100\Omega$; $V_{GE} = 15\text{V}$

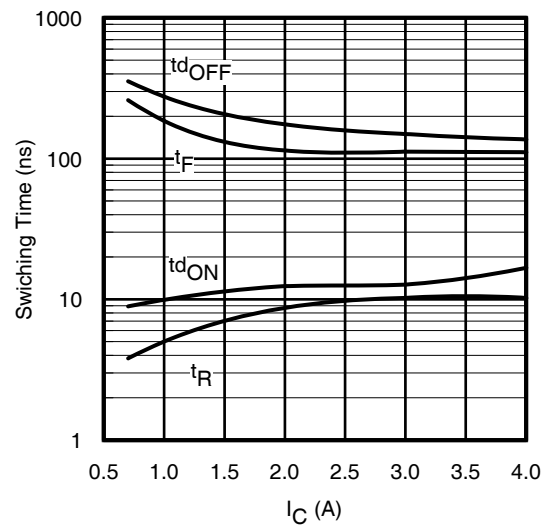

Fig. 15 - Typ. Switching Time vs. I_C

$T_J = 150^\circ\text{C}$; $L = 7.1\text{mH}$; $V_{CE} = 400\text{V}$; $R_G = 100\Omega$; $V_{GE} = 15\text{V}$

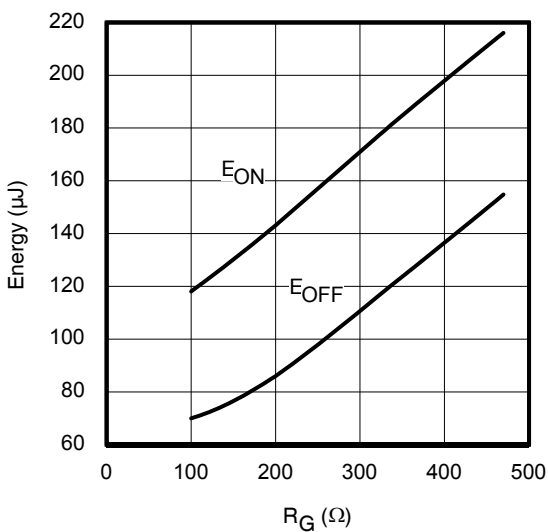

Fig. 16 - Typ. Energy Loss vs. R_G

$T_J = 150^\circ\text{C}$; $L = 7.1\text{mH}$; $V_{CE} = 400\text{V}$; $I_{CE} = 2.0\text{A}$; $V_{GE} = 15\text{V}$

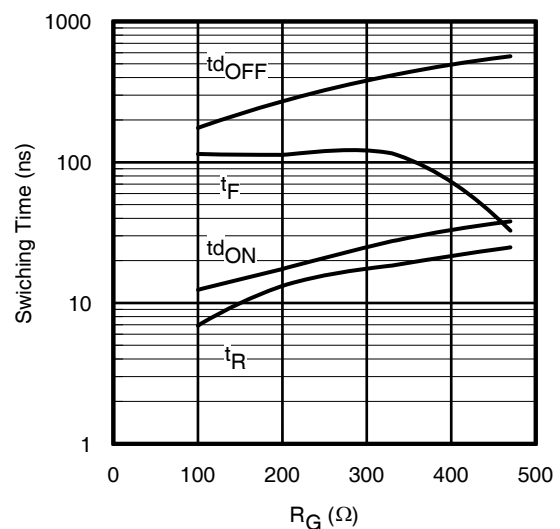

Fig. 17 - Typ. Switching Time vs. R_G

$T_J = 150^\circ\text{C}$; $L = 7.1\text{mH}$; $V_{CE} = 400\text{V}$; $I_{CE} = 2.0\text{A}$; $V_{GE} = 15\text{V}$

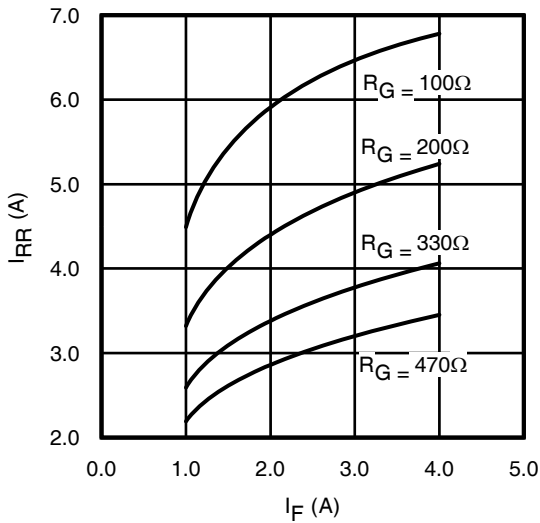

Fig. 18 - Typical Diode I_{RR} vs. I_F
 $T_J = 150^\circ\text{C}$

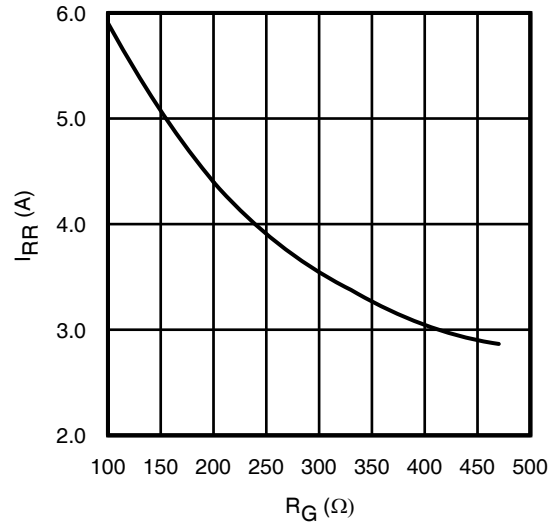

Fig. 19 - Typical Diode I_{RR} vs. R_G
 $T_J = 150^\circ\text{C}$; $I_F = 2.0\text{A}$

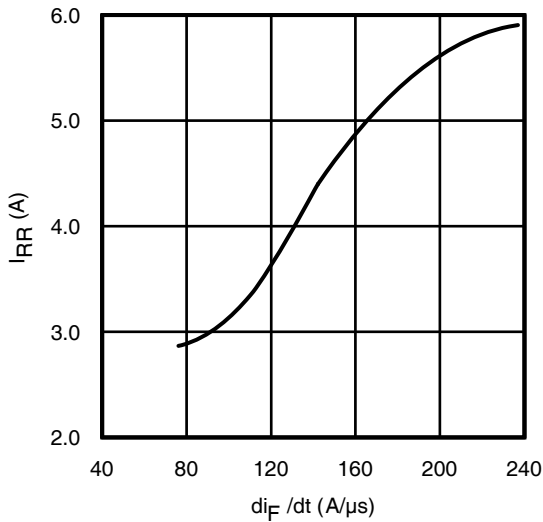

Fig. 20 - Typical Diode I_{RR} vs. di_F/dt
 $V_{CC} = 400\text{V}$; $V_{GE} = 15\text{V}$; $I_F = 2.0\text{A}$; $T_J = 150^\circ\text{C}$

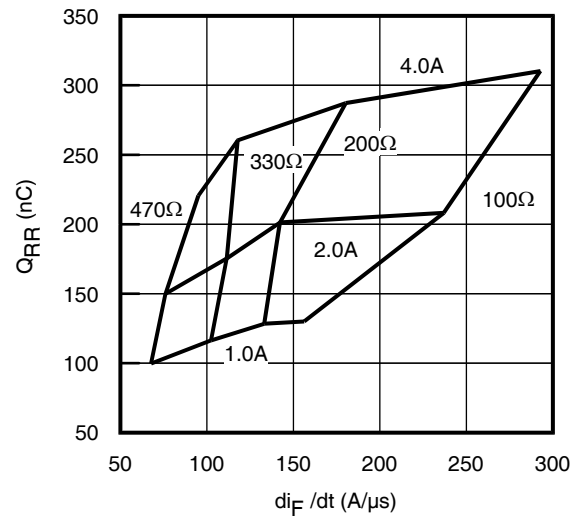

Fig. 21 - Typical Diode Q_{RR}
 $V_{CC} = 400\text{V}$; $V_{GE} = 15\text{V}$; $T_J = 150^\circ\text{C}$

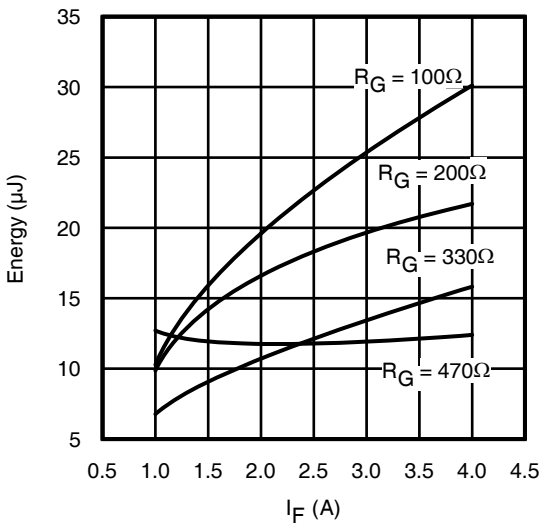

Fig. 22 - Typ. Diode E_{RR} vs. I_F
 $T_J = 150^\circ\text{C}$

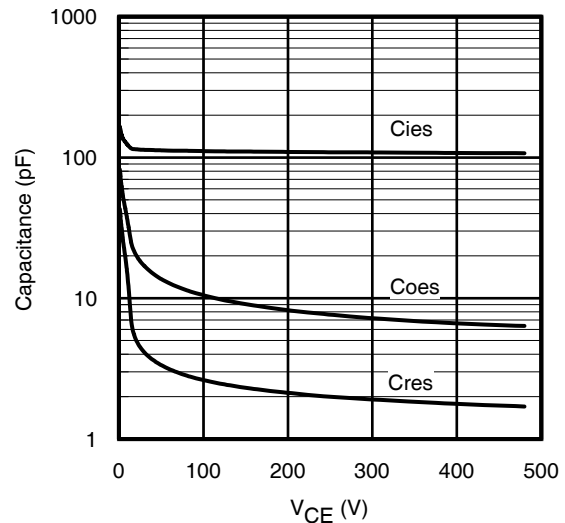

Fig. 23 - Typ. Capacitance vs. V_{CE}
 $V_{GE} = 0\text{V}$; $f = 1\text{MHz}$

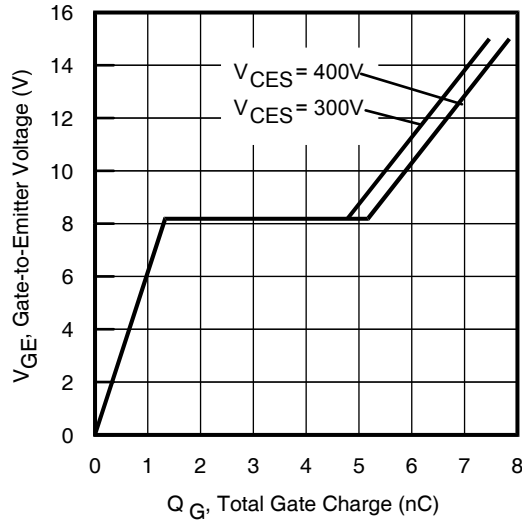

Fig. 23 - Typical Gate Charge vs. V_{GE}
 $I_{CE} = 2.0A$

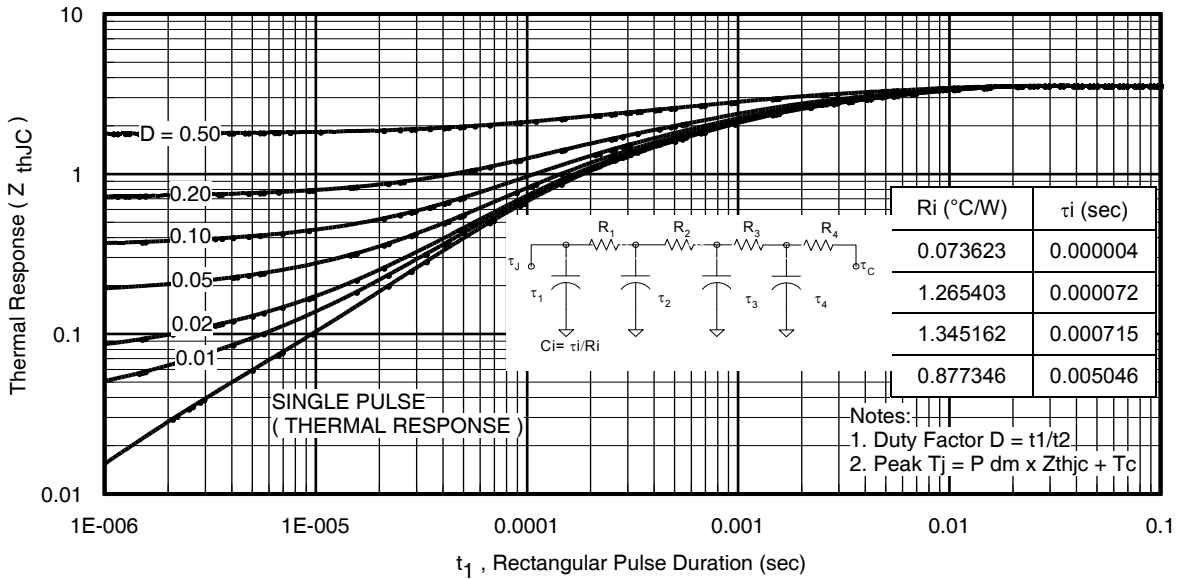

Fig. 24 - Maximum Transient Thermal Impedance, Junction-to-Case (IGBT)

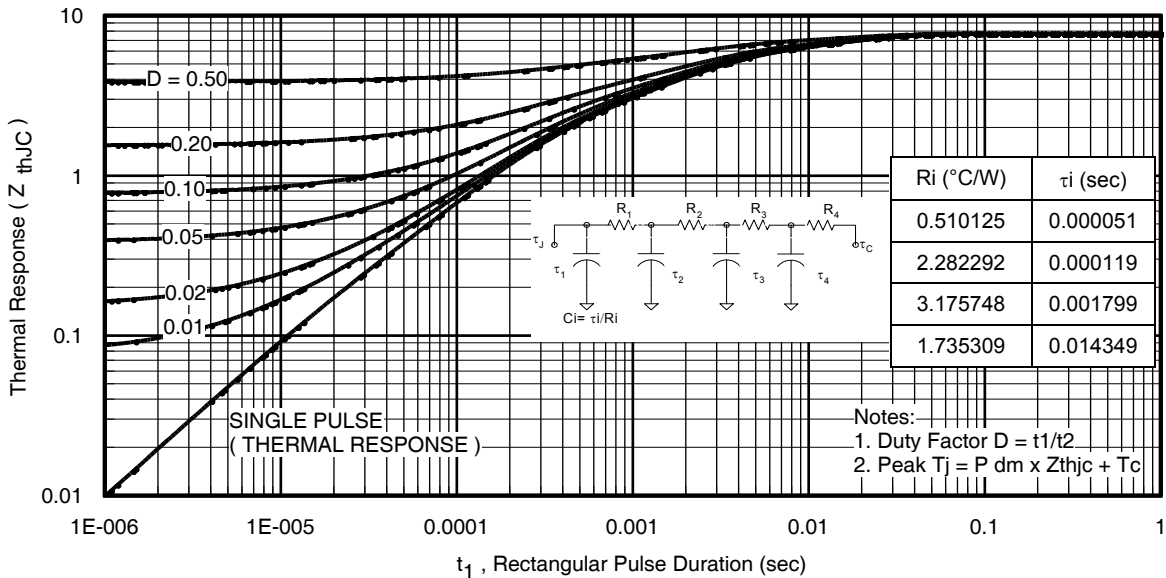
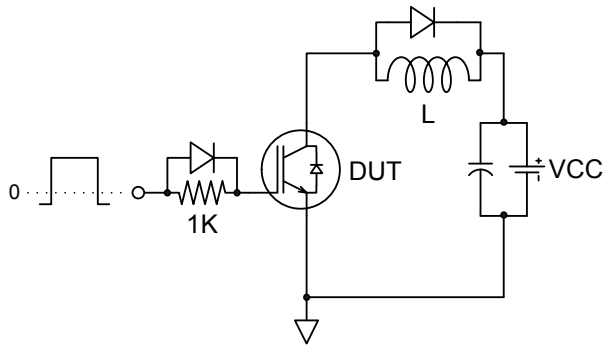
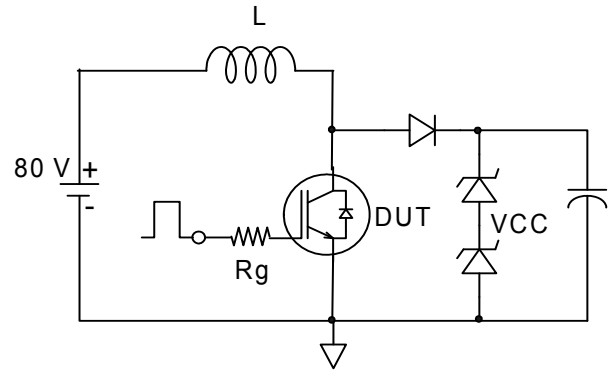
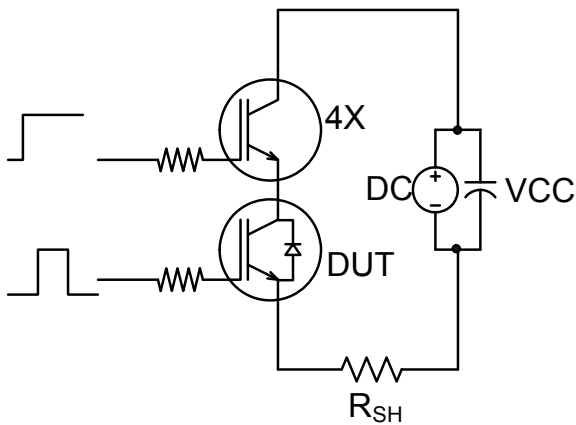
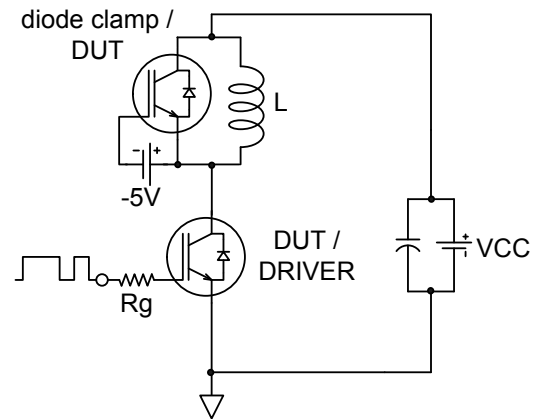
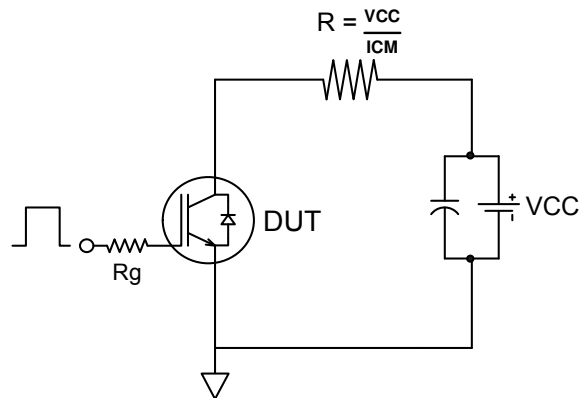

Fig. 25 - Maximum Transient Thermal Impedance, Junction-to-Case (DIODE)

Fig.C.T.1 - Gate Charge Circuit (turn-off)

Fig.C.T.2 - RBSOA Circuit

Fig.C.T.3 - S.C. SOA Circuit

Fig.C.T.4 - Switching Loss Circuit

Fig. C.T.5 - Resistive Load Circuit

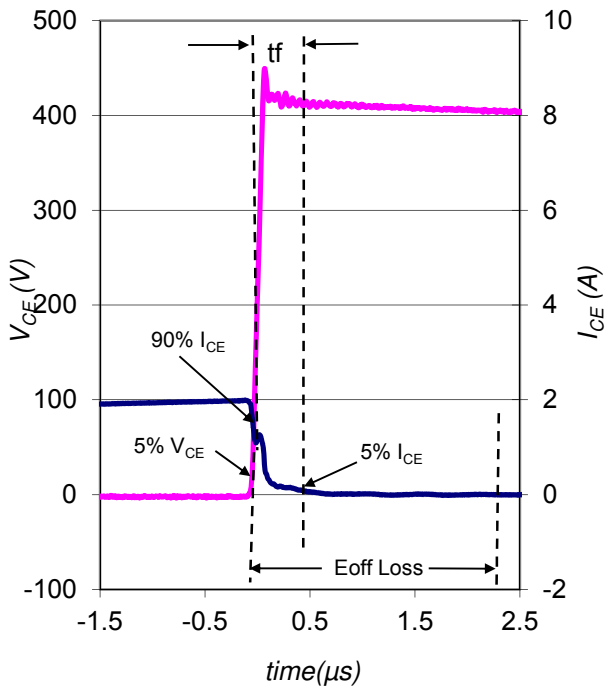

Fig. WF1 - Typ. Turn-off Loss Waveform
@ $T_J = 150^\circ\text{C}$ using Fig. CT.4

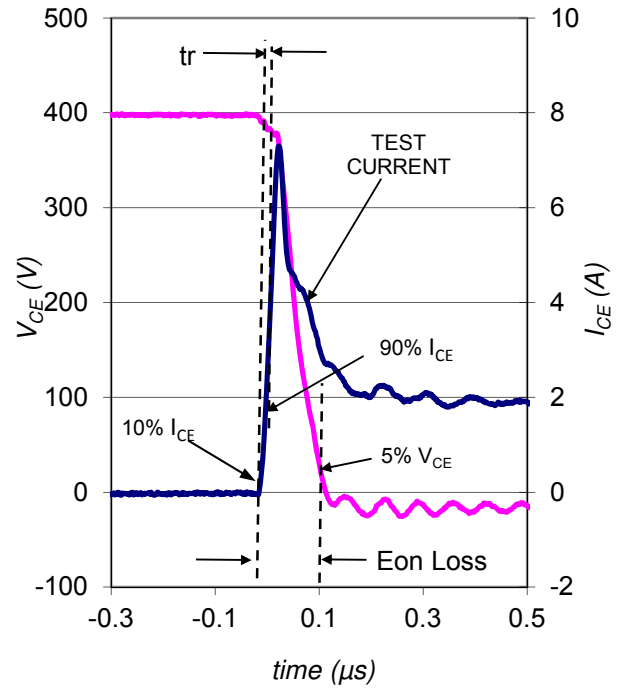

Fig. WF2 - Typ. Turn-on Loss Waveform
@ $T_J = 150^\circ\text{C}$ using Fig. CT.4

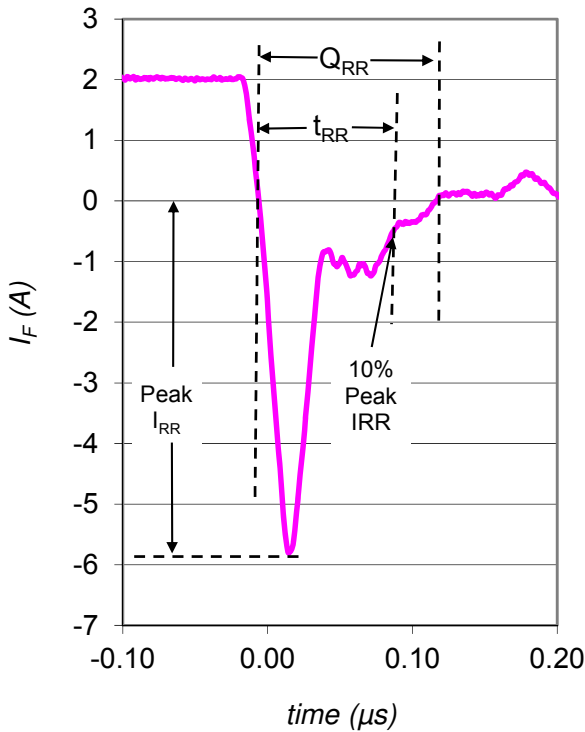

Fig. WF3 - Typ. Diode Recovery Waveform
@ $T_J = 150^\circ\text{C}$ using Fig. CT.4

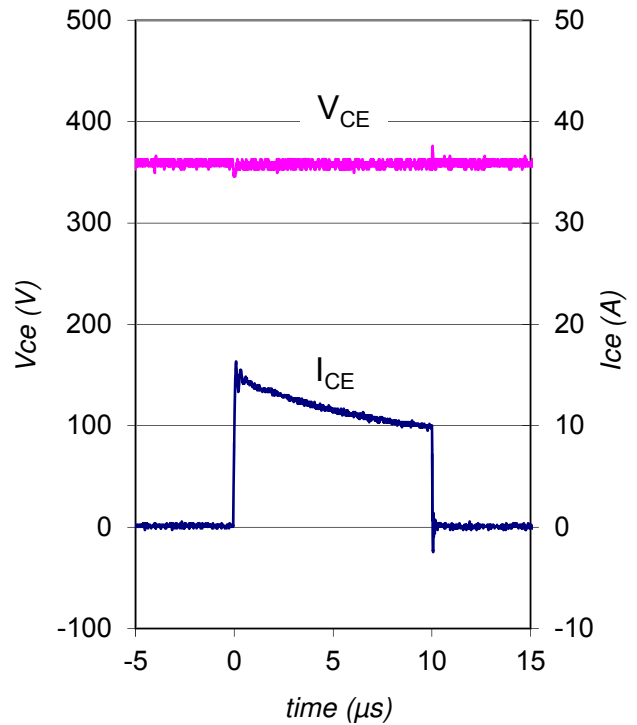
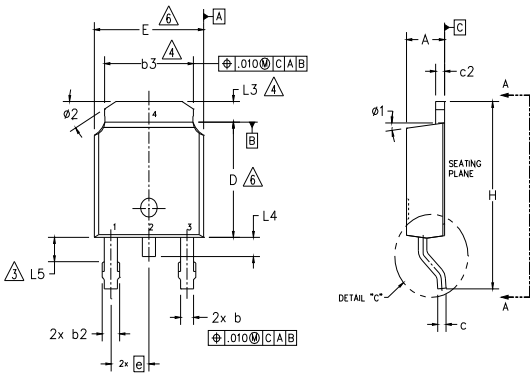

Fig. WF4 - Typ. S.C. Waveform
@ $T_J = 150^\circ\text{C}$ using Fig. CT.3

D-Pak (TO-252AA) Package Outline

Dimensions are shown in millimeters (inches)



NOTES:

- 1.- DIMENSIONING AND TOLERANCING PER ASME Y14.5M-1994
- 2.- DIMENSIONS ARE SHOWN IN INCHES [MILLIMETERS].
- △- LEAD DIMENSION UNCONTROLLED IN L5.
- △- DIMENSION D1, E1, L3 & b3 ESTABLISH A MINIMUM MOUNTING SURFACE FOR THERMAL PAD.
- 5.- SECTION C-C DIMENSIONS APPLY TO THE FLAT SECTION OF THE LEAD BETWEEN .005 AND 0.10 [0.13 AND 0.25] FROM THE LEAD TIP.
- △- DIMENSION D & E DO NOT INCLUDE MOLD FLASH. MOLD FLASH SHALL NOT EXCEED .005 [0.13] PER SIDE. THESE DIMENSIONS ARE MEASURED AT THE OUTMOST EXTREMES OF THE PLASTIC BODY.
- △- DIMENSION b1 & c1 APPLIED TO BASE METAL ONLY.
- △- DATUM A & B TO BE DETERMINED AT DATUM PLANE H.
- 9.- OUTLINE CONFORMS TO JEDEC OUTLINE TO-252AA.

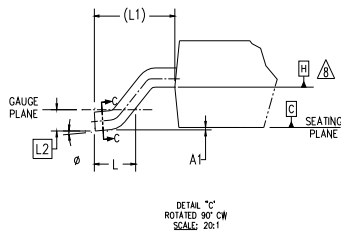
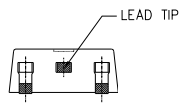

DETAIL "C"
ROTATED 90° CW
SCALE: 20:1

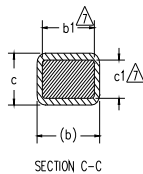
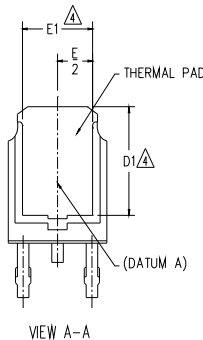

SYMBOL	DIMENSIONS				NOTES
	MILLIMETERS		INCHES		
	MIN.	MAX.	MIN.	MAX.	
A	2.18	2.39	.086	.094	
A1	-	0.13	-	.005	
b	0.64	0.89	.025	.035	7
b1	0.65	0.79	.025	.031	
b2	0.76	1.14	.030	.045	
b3	4.95	5.46	.195	.215	4
c	0.46	0.61	.018	.024	
c1	0.41	0.56	.016	.022	7
c2	0.46	0.89	.018	.035	
D	5.97	6.22	.235	.245	6
D1	5.21	-	.205	-	4
E	6.35	6.73	.250	.265	6
E1	4.32	-	.170	-	4
e	2.29 BSC		.090 BSC		
H	9.40	10.41	.370	.410	
L	1.40	1.78	.055	.070	
L1	2.74 BSC		.108 REF.		
L2	0.51 BSC		.020 BSC		
L3	0.89	1.27	.035	.050	4
L4	-	1.02	-	.040	
L5	1.14	1.52	.045	.060	3
ø	0"	10"	0"	10"	
ø1	0"	15"	0"	15"	
ø2	25"	35"	25"	35"	

LEAD ASSIGNMENTS

HEXFET

- 1.- GATE
- 2.- DRAIN
- 3.- SOURCE
- 4.- DRAIN

IGBT & CoPAK

- 1.- GATE
- 2.- COLLECTOR
- 3.- EMITTER
- 4.- COLLECTOR

D-Pak (TO-252AA) Part Marking Information

EXAMPLE: THIS IS AN IRFR120
WITH ASSEMBLY
LOT CODE 1234
ASSEMBLED ON WW 16, 1999
IN THE ASSEMBLY LINE 'A'

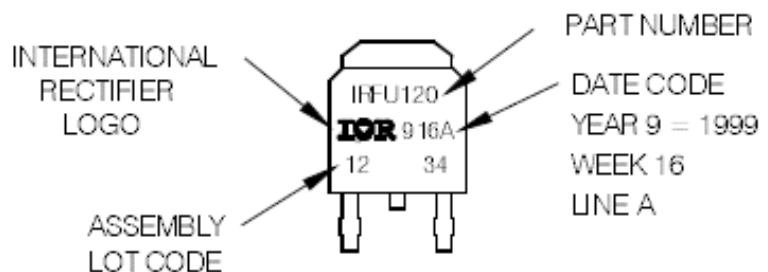

Note: For the most current drawing please refer to IR website at <http://www.irf.com/package/>

D-Pak (TO-252AA) Tape and Reel Information

Dimensions are shown in millimeters (inches)

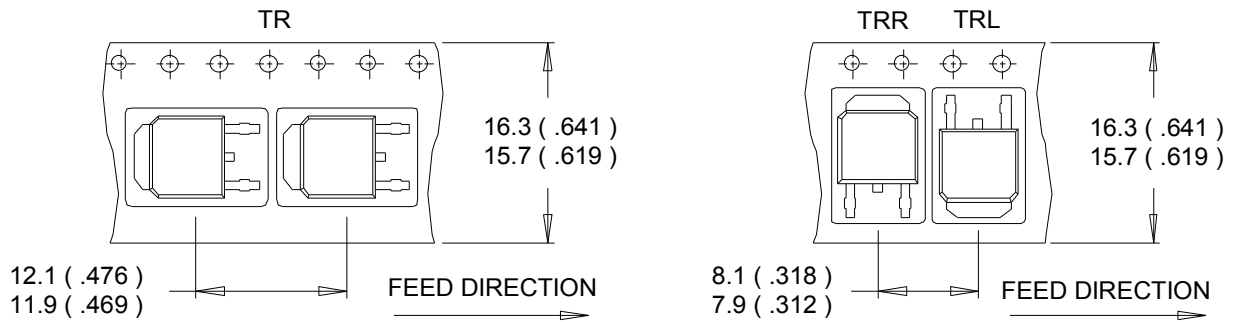

NOTES :

1. CONTROLLING DIMENSION : MILLIMETER.
2. ALL DIMENSIONS ARE SHOWN IN MILLIMETERS (INCHES).
3. OUTLINE CONFORMS TO EIA-481 & EIA-541.

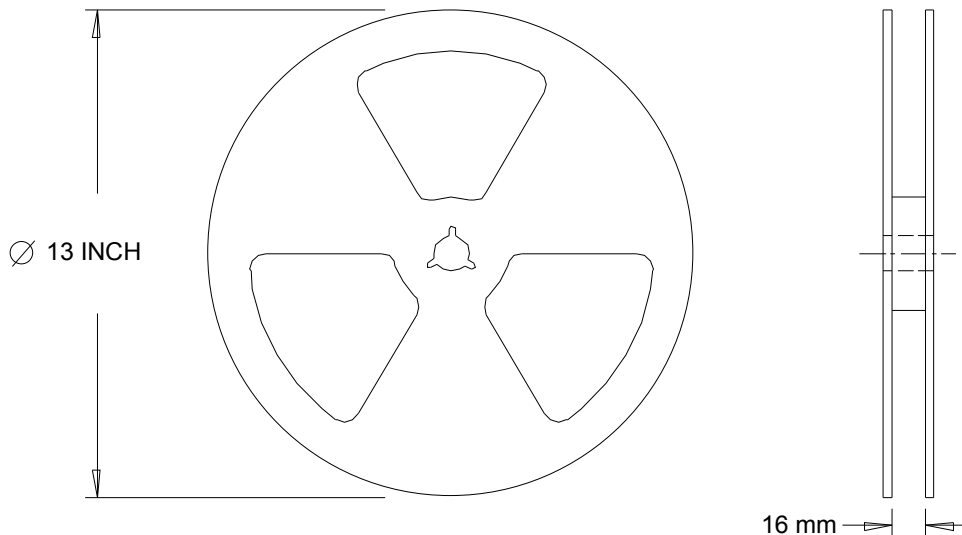

NOTES :

1. OUTLINE CONFORMS TO EIA-481.

Note: For the most current drawing please refer to IR website at <http://www.irf.com/package/>

Qualification Information[†]

Qualification Level	Industrial [†]	
Moisture Sensitivity Level	D-Pak	MSL1
RoHS Compliant	Yes	

† Qualification standards can be found at International Rectifier's web site: <http://www.irf.com/product-info/reliability/>

†† Applicable version of JEDEC standard at the time of product release.