

NOTES:

1. METALSHELLS: STEEL; min. 315µm TIN over 40-80µm NICKEL
2. INSULATORS: PBT GF UL 94 V-0, BLACK
3. CONTACTS: COPPER ALLOY; PLATING (SEE PART NO):
 - PLEASE ADD A for GOLD FLASH over NICKEL (PREFERRED TYPE)
 - PLEASE ADD B for 20µm HARD GOLD over min. 50µm NICKEL
 - PLEASE ADD C for 30µm HARD GOLD over min. 50µm NICKEL
4. METAL BRACKETS:
 - ZINC DIE CAST; 300µm COPPER/40-120µm NICKEL/120-200µm TIN
5. THREADED INSERTS: COPPER ALLOY; min. 200µm TIN over 80µm NICKEL
6. FIXING PLATE: PBT GF UL 94 V-0, BLACK
7. P.C.B. HOLE DRILLINGS ON SHEET 2
8. MAXIMUM TORQUE VALUE FOR THREAD: 6 in.LB
9. CONNECTOR IS PART MARKET: 164□15639X CONEC ABC (see note 3)

Directive 2002/95/EC RoHS compliant

THIS DRAWING MAY NOT BE COPIED OR REPRODUCED IN ANY WAY, AND MAY NOT BE PASSED ON TO A THIRD PARTY WITHOUT WRITTEN PERMISSION. OWNERSHIP AND COPYRIGHT OF CONEC GmbH DO NOT ALTER CAD DRAWING BY HAND	tolerance		dim. in mm	scale: 2:1 (5:1)		
				material: SEE NOTES		
	drawn	11.07.14	Henneboel	title: D-SUB DUAL PORT 15.88mm 37po. FEMALE / FEMALE threaded insert, metal bracket, fixing plate dwg no: DIN-A3		
	appd.	11.07.14	Lehmenkühler			
	norm					
d-old						
a	Original				part no: 164□15639X (see note 3)	
rev.	description	date			name	sh:1/2

P.C.B. HOLE DRILLINGS
(P.C.B. TOP SIDE)

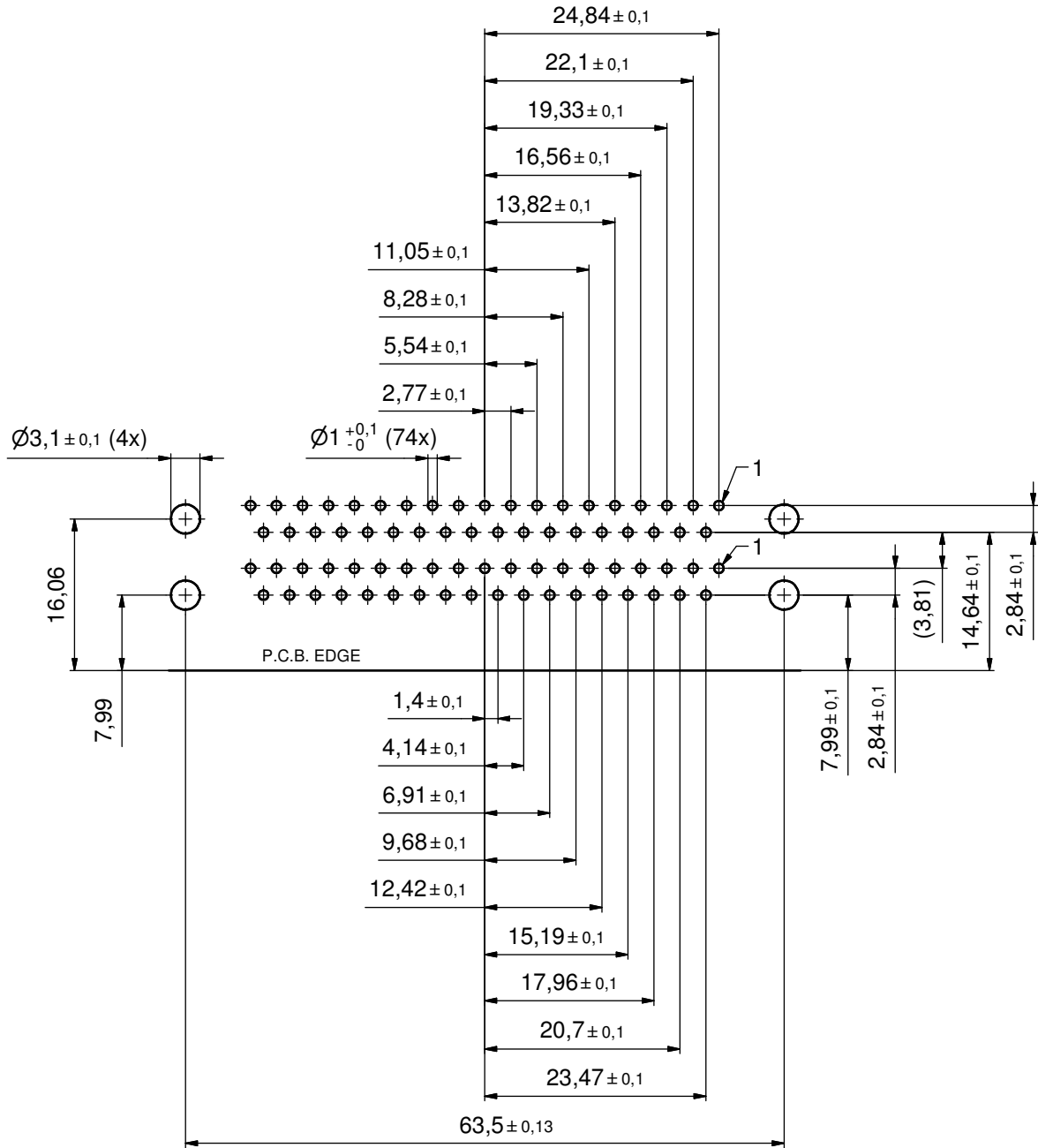

THIS DRAWING MAY NOT BE COPIED OR REPRODUCED IN ANY WAY, AND MAY NOT BE PASSED ON TO A THIRD PARTY WITHOUT WRITTEN PERMISSION. OWNERSHIP AND COPYRIGHT OF CONEC GmbH DO NOT ALTER CAD DRAWING BY HAND				tolerance		scale: 2:1	
					dim. in mm	material: SEE SHEET 1	
				date	name	title: P.C.B. HOLE DRILLINGS D-SUB DUAL PORT 15,88mm 37pos. FEMALE / FEMALE	
				drawn 11.07.14	Heneboel		
				appd. 11.07.14	Lehmenkühler		
				norm			
				d-old		dwg no:	
	a	Original		CONEC [®]		16K1A3484	DIN-A3
	rev.	description	date			name	part no: SEE SHEET 1