

BTL Drive Single-phase Full-wave Fan Motor Driver**AM4953****General Description**

The AM4953 is a single-phase BTL output fan motor driver designed by bipolar process. This IC features high efficiency, silent operation and includes lock shutdown and automatic restart functions. When the motor is under lock condition, the lock shutdown function turns off the output current. When the lock condition is removed, the IC will restart automatically and allow DC fan to run. It is applied for high reliability and low noise application, such as personal computers, notebook, car audio, CPU cooling systems and power supplies in consumer electronics systems.

The AM4953 is available in MSOP-10, SSOP-10, MSOP-8, SOIC-8 and PSOP-8 packages.

Features

- BTL Output Single-phase Full-wave Linear Drive (Gain Resistor=1k to 360k Ω , Gain=51dB)
- Support Low-voltage Drive and Feature a Wide Usable Voltage Range (2.2V to 16V)
- Low Saturation Output (High Side and Low Side Saturation Voltage): $V_{SAT_TOTAL}=1.2V$ (typical, $I_{OUT}=300mA$)
- Built-in Lock Protection and Automatic Restart Circuits
- Built-in FG/RD Output
- Built-in Hall Sensor Bias ($V_{HB}=1.45V$)
- Thermal Protection Circuit
- Small-sized, High Thermal Capacity Package

Applications

- Notebook, Personal Computers
- Power Supplies in Consumer Electronics, Car Audio
- CPU Cooling Systems

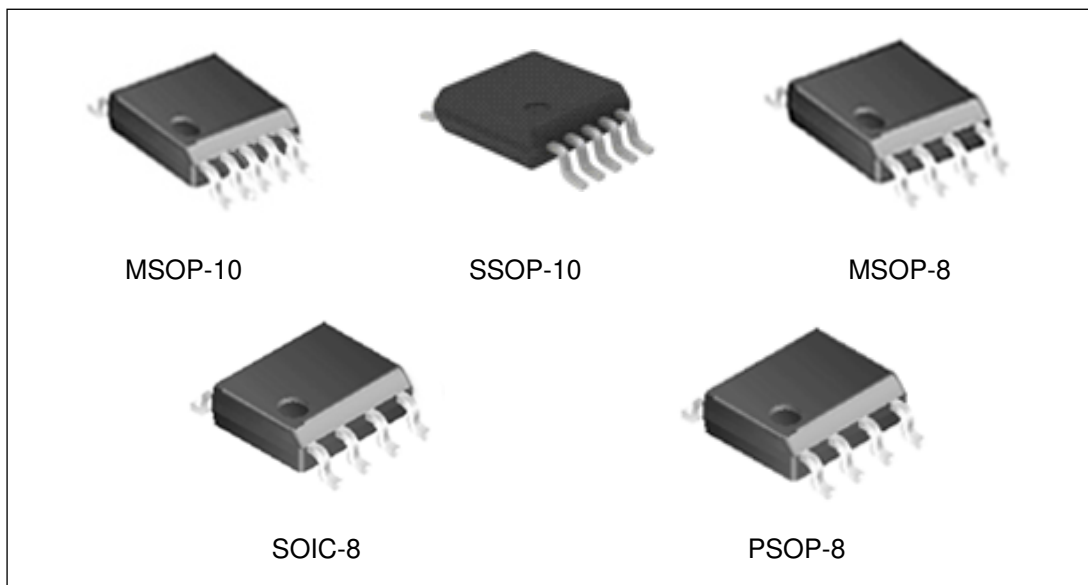

Figure 1. Package Types of AM4953

BTL Drive Single-phase Full-wave Fan Motor Driver

AM4953

Pin Configuration

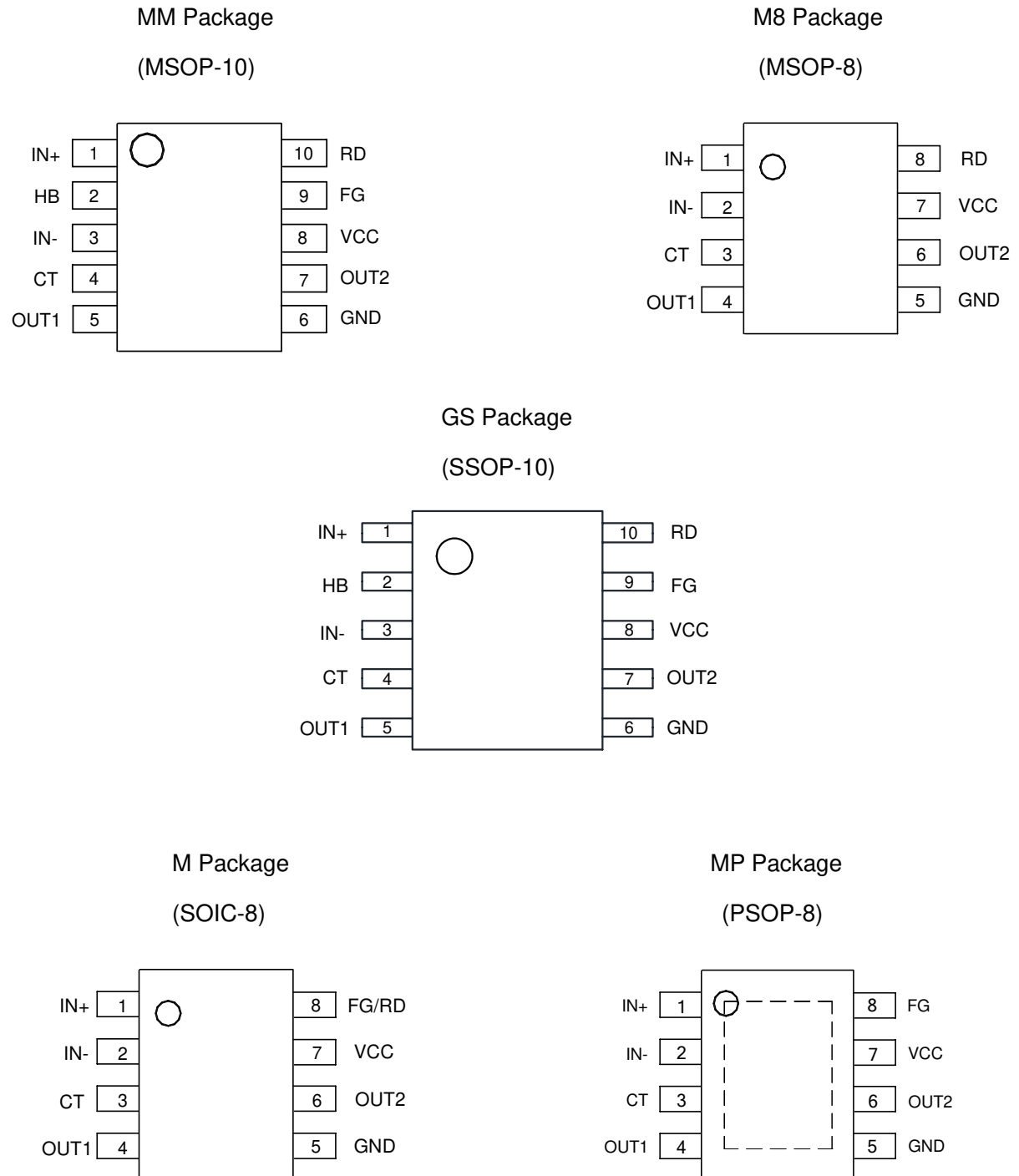
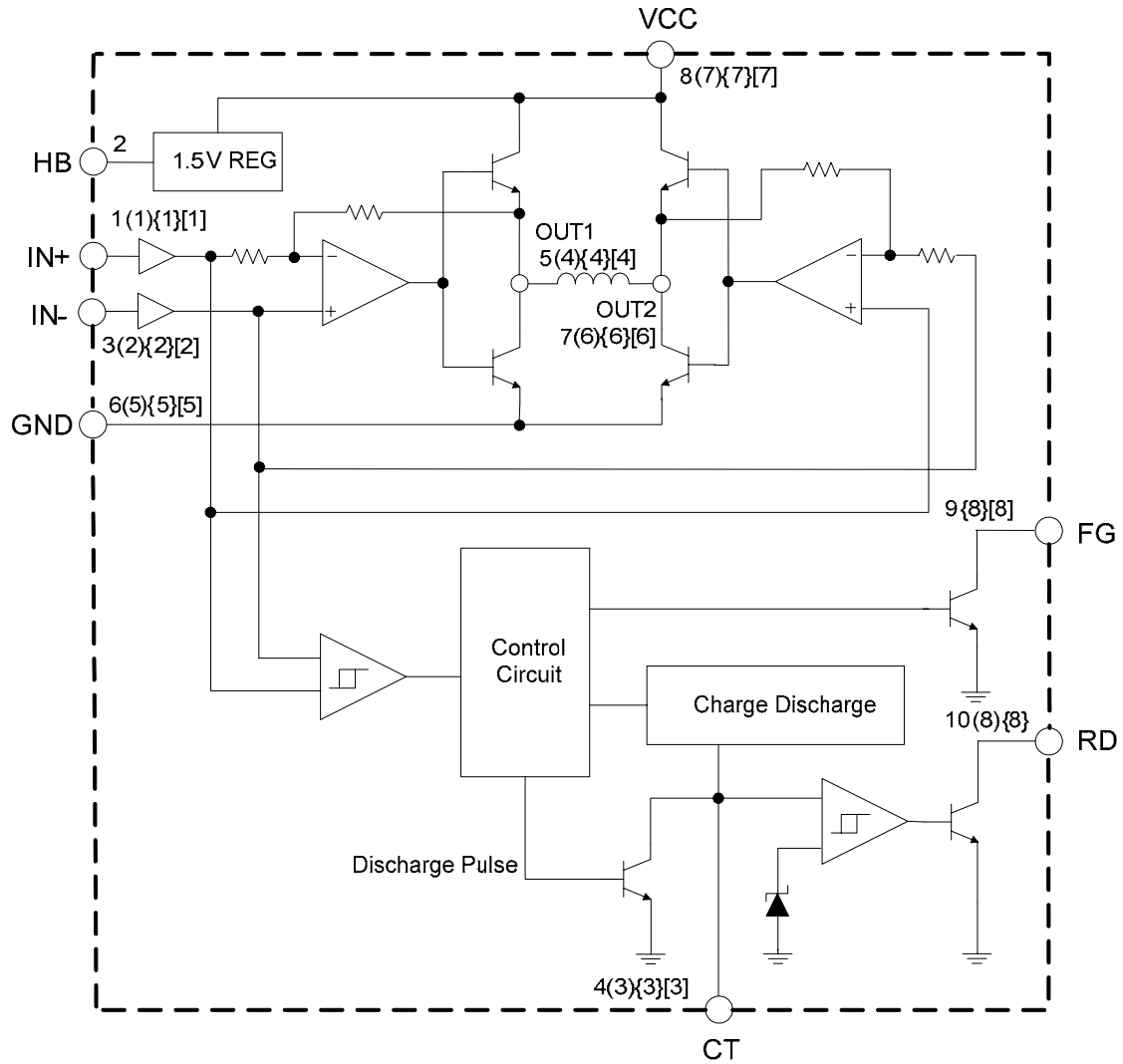

Figure 2. Pin Configuration of AM4953 (Top View)

Functional Block Diagram



A(B) {C} [D]
 A for MSOP-10/SSOP-10
 B for MSOP-8
 C for SOIC-8
 D for PSOP-8

Figure 3. Functional Block Diagram of AM4953



BTL Drive Single-phase Full-wave Fan Motor Driver

AM4953

Ordering Information

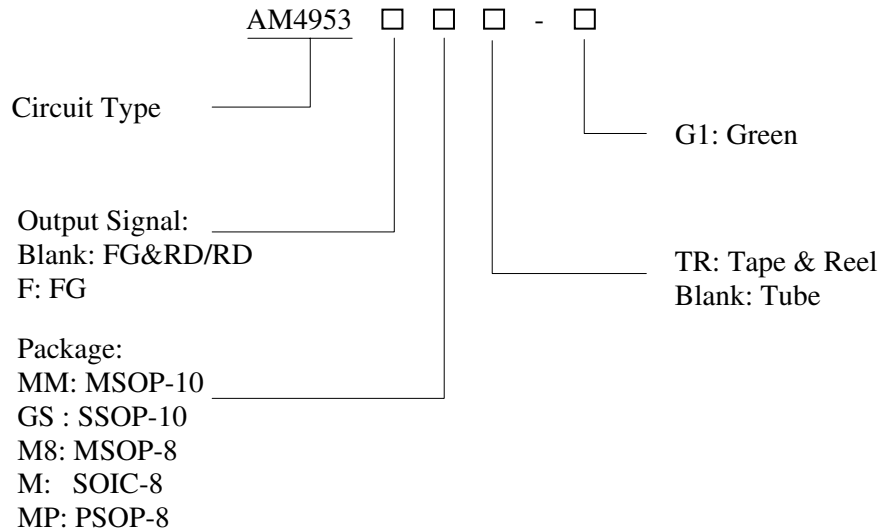

Package	Temperature Range	Output Signal	Part Number	Marking ID	Packing Type
MSOP-10	-40 to 105°C	FG & RD	AM4953MM-G1	4953MM-G1	Tube
			AM4953MMTR-G1	4953MM-G1	Tape & Reel
SSOP-10		FG & RD	AM4953GS-G1	4953GS-G1	Tube
			AM4953GSTR-G1	4953GS-G1	Tape & Reel
MSOP-8		RD	AM4953M8-G1	4953M8-G1	Tube
			AM4953M8TR-G1	4953M8-G1	Tape & Reel
SOIC-8		RD	AM4953M-G1	4953M-G1	Tube
			AM4953MTR-G1	4953M-G1	Tape & Reel
		FG	AM4953FM-G1	4953FM-G1	Tube
			AM4953FMTR-G1	4953FM-G1	Tape & Reel
PSOP-8	FG	AM4953FMP-G1	4953FMP-G1	Tube	
		AM4953FMPTR-G1	4953FMP-G1	Tape & Reel	

BCD Semiconductor's Pb-free products, as designated with "G1" suffix in the part number, are RoHS compliant and green.

**BTL Drive Single-phase Full-wave Fan Motor Driver****AM4953****Absolute Maximum Ratings (Note 1, T_A=25°C)**

Parameter	Symbol	Value		Unit
Supply Voltage	V _{CC}	20		V
Peak Output Current	I _{OUT}	800		mA
FG/RD Pull-up Voltage	V _{FG} /V _{RD}	15		V
FG/RD Output Current	I _{FG} /I _{RD}	10		mA
Thermal Resistance (Junction to Ambient)	θ _{JA}	MSOP-10	195	°C/W
		MSOP-8	205	
		SSOP-10	155	
		SOIC-8	160	
		PSOP-8	110	
Thermal Resistance (Junction to Case)	θ _{JC}	MSOP-10	46	°C/W
		MSOP-8	48	
		SSOP-10	39	
		SOIC-8	40	
		PSOP-8	36	
Power Dissipation	P _D	MSOP-10	585	mW
		MSOP-8		
		SSOP-10	800	
		SOIC-8	780	
		PSOP-8	960	
Operating Temperature	T _{OP}	-40 to 125		°C
Storage Temperature	T _{STG}	-55 to 150		°C
ESD (Human Body Model)	ESD	4000		V
ESD (Machine Model)	ESD	200		V

Note 1: Stresses greater than those listed under “Absolute Maximum Ratings” may cause permanent damage to the device. These are stress ratings only, and functional operation of the device at these or any other conditions beyond those indicated under “Recommended Operating Conditions” is not implied. Exposure to “Absolute Maximum Ratings” for extended periods may affect device reliability.

Recommended Operating Conditions

Parameter	Symbol	Min	Max	Unit
Supply Voltage	V _{CC}	2.2	16	V
Hall Input Voltage	V _{ICM}	0	V _{CC} -1.5	V
Operating Ambient Temperature	T _A	-40	105	°C

**BTL Drive Single-phase Full-wave Fan Motor Driver****AM4953****Electrical Characteristics** $V_{CC}=12V$, $T_A=25^{\circ}C$, unless otherwise specified.

Parameter	Symbol	Conditions	Min	Typ	Max	Unit
Supply Current	I_{CC1}	$V_{CT}=L$	6	8	9.6	mA
	I_{CC2}	$V_{CT}=H$	2	4	6	mA
CT Charge Current	I_{CHG}		1	1.7	2.5	μA
CT Discharge Current	I_{DHG}		0.15	0.27	0.36	μA
CT Charge/Discharge Current Ratio	R_{CT}	I_{CHG} / I_{DHG}	5	7	10	
CT Clamp Voltage	V_{CL}		1.25	1.45	1.65	V
CT Comparator Voltage	V_{CP}		0.25	0.45	0.65	V
OUT Low Saturation Voltage	V_{SAT_L}	$I_{OUT}=300mA$		0.25	0.45	V
OUT High Saturation Voltage	V_{SAT_H}	$I_{OUT}=300mA$		0.95	1.3	V
Hall Input Sensitivity	V_{HN}			8	20	mV
FG Low Level Voltage	V_{FG}	$I_{FG}=5mA$		0.15	0.3	V
FG Leakage Current	I_{FGL}	$V_{FG}=15V$		1	10	μA
RD Low Level Voltage	V_{RD}	$I_{RD}=5mA$		0.15	0.3	V
RD Leakage Current	I_{RDL}	$V_{RD}=15V$		1	10	μA
HB Voltage	V_{HB}	$I_{HB}=5mA$	1.3	1.45	1.6	V

Typical Performance Characteristics

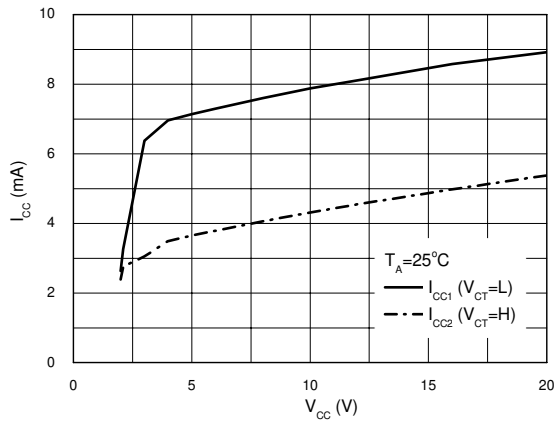

Figure 4. I_{CC} vs. V_{CC}

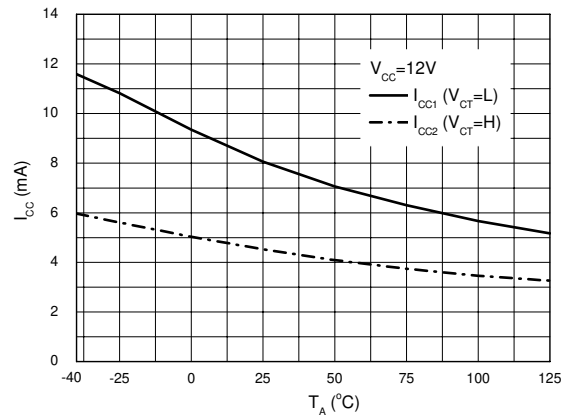

Figure 5. I_{CC} vs. T_A

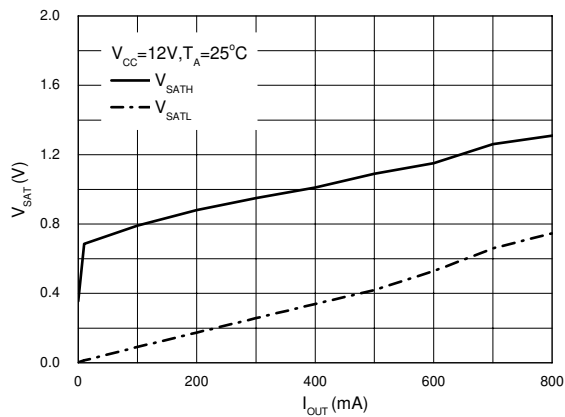

Figure 6. V_{SAT} vs. I_{OUT}

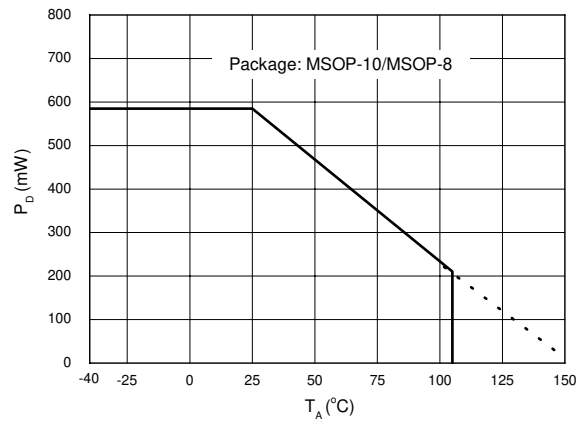

Figure 7. P_D vs. T_A

Typical Performance Characteristics (Continued)

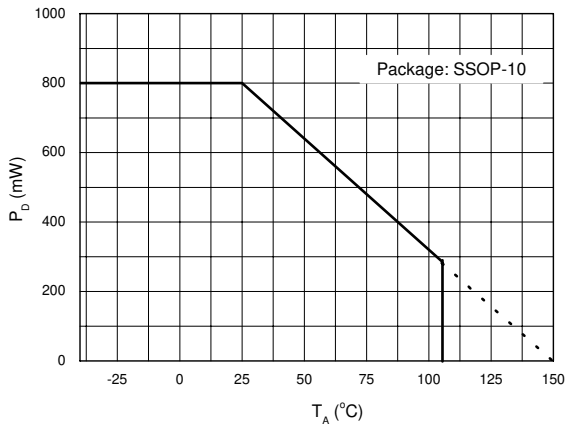

Figure 8. P_D vs. T_A

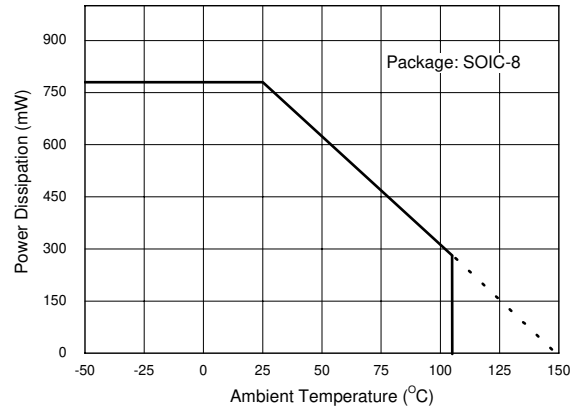

Figure 9. P_D vs. T_A

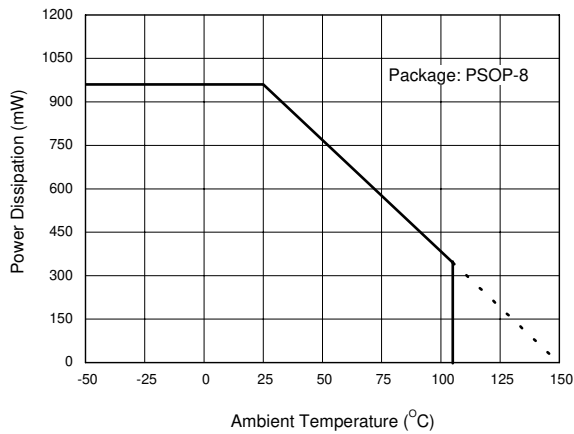
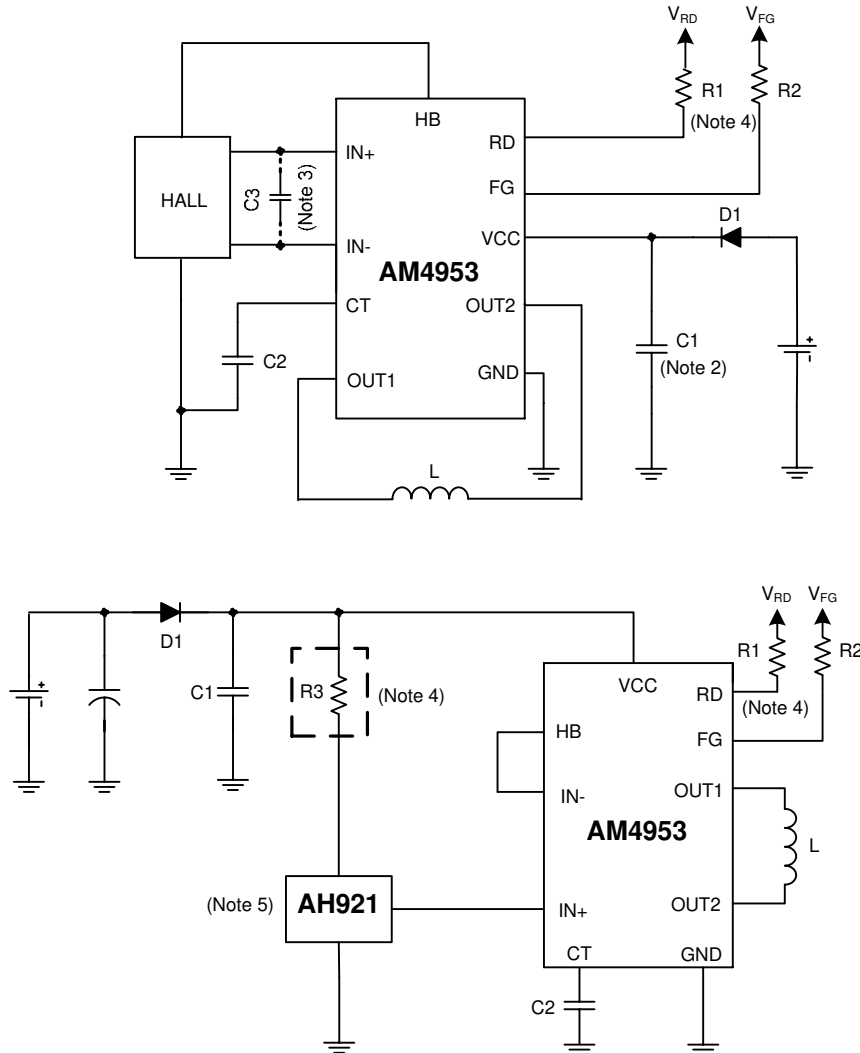

Figure 10. P_D vs. T_A

**BTL Drive Single-phase Full-wave Fan Motor Driver****AM4953****Truth Table**

Items	IN-	IN+	CT	OUT1	OUT2	FG	RD	Mode
1	H	L	L	H	L	L	L	Purring Rotation
2	L	H		L	H	H		
3			H	Off	OFF		H	Lock Protection

BTL Drive Single-phase Full-wave Fan Motor Driver
AM4953
Typical Application

Note 2: Adding D1 can protect the IC from destruction by reverse connection. If D1 is used, it is necessary to insert a capacitor C1 to provide a regenerative current route. Similarly, if there is no nearby capacitor on the fan power supply line, C1 will also be necessary to improve reliability. Its capacity should be larger than 2.2 μ F.

Note 3: If the line between Hall sensor output and Hall sensor input of IC is long, the noise may occur in this line. But it can be eliminated by adding a capacitor C3.

Note 4: Each of R1 and R2 is recommended to be 51k Ω typical. R3 is recommended to be 2k and must be added when V_{CC} is larger than 20V.

Note 5: The package of AH921 is SOT-23-3. If it is packaged in TO-92S-3, please exchange IN- with IN+.

Figure 11. Typical Application of AM4953

Mechanical Dimensions

MSOP-10

Unit: mm(inch)

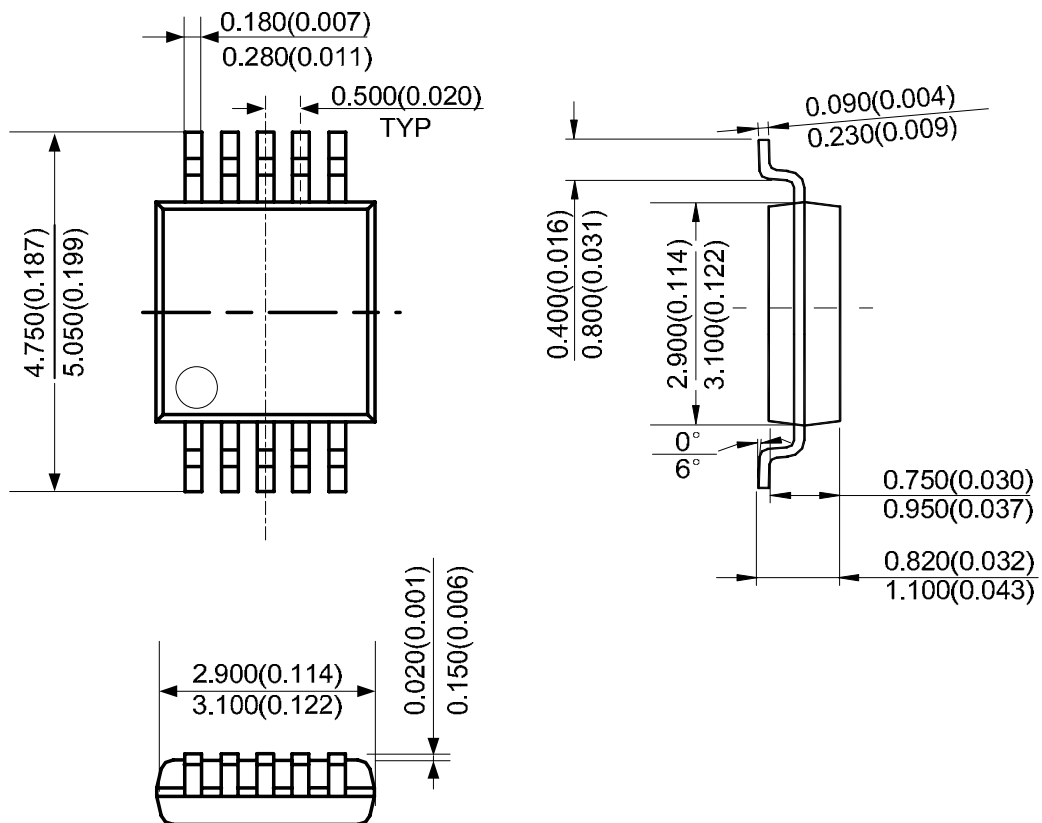

Note: Eject hole, oriented hole and mold mark is optional.

Mechanical Dimensions (Continued)

SSOP-10

Unit: mm(inch)

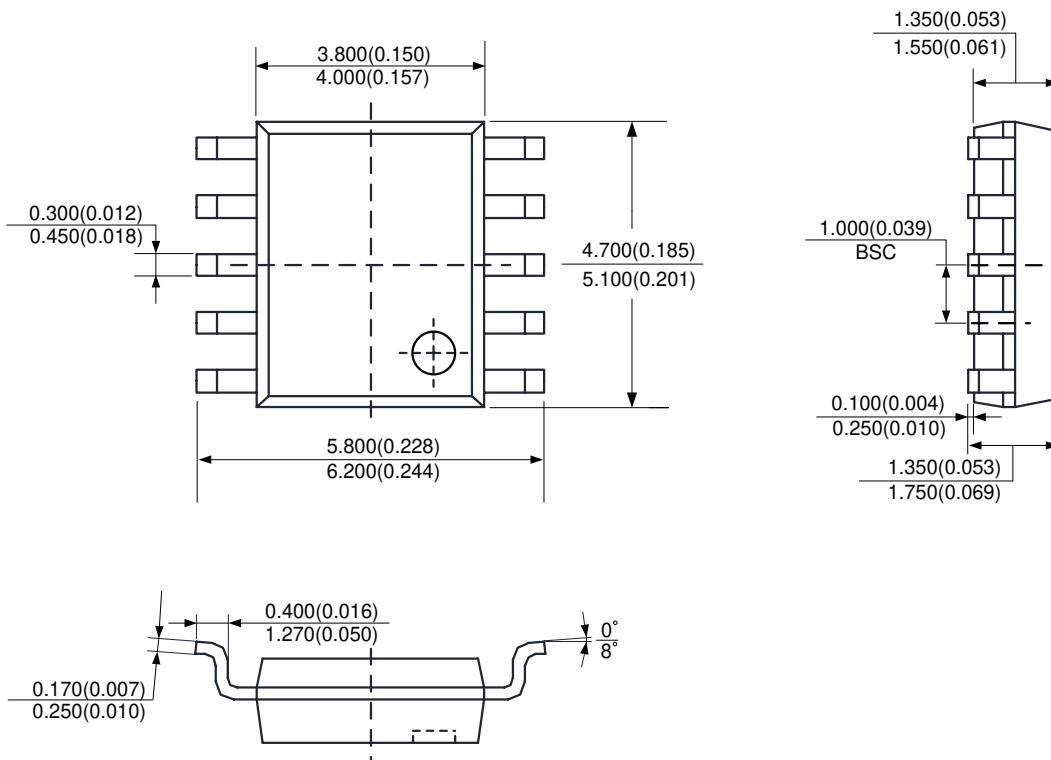

Mechanical Dimensions (Continued)

MSOP-8

Unit: mm(inch)

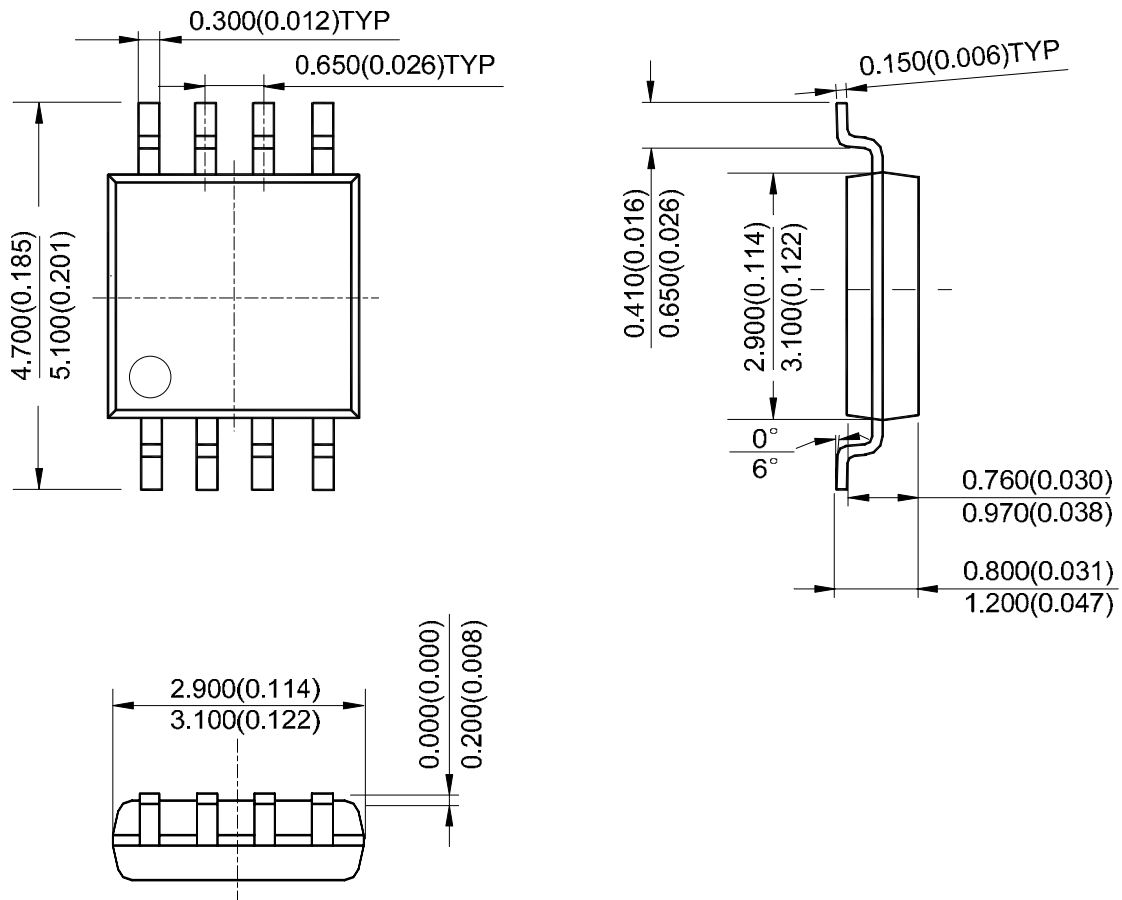

Note: Eject hole, oriented hole and mold mark is optional.

Mechanical Dimensions (Continued)

SOIC-8

Unit: mm(inch)

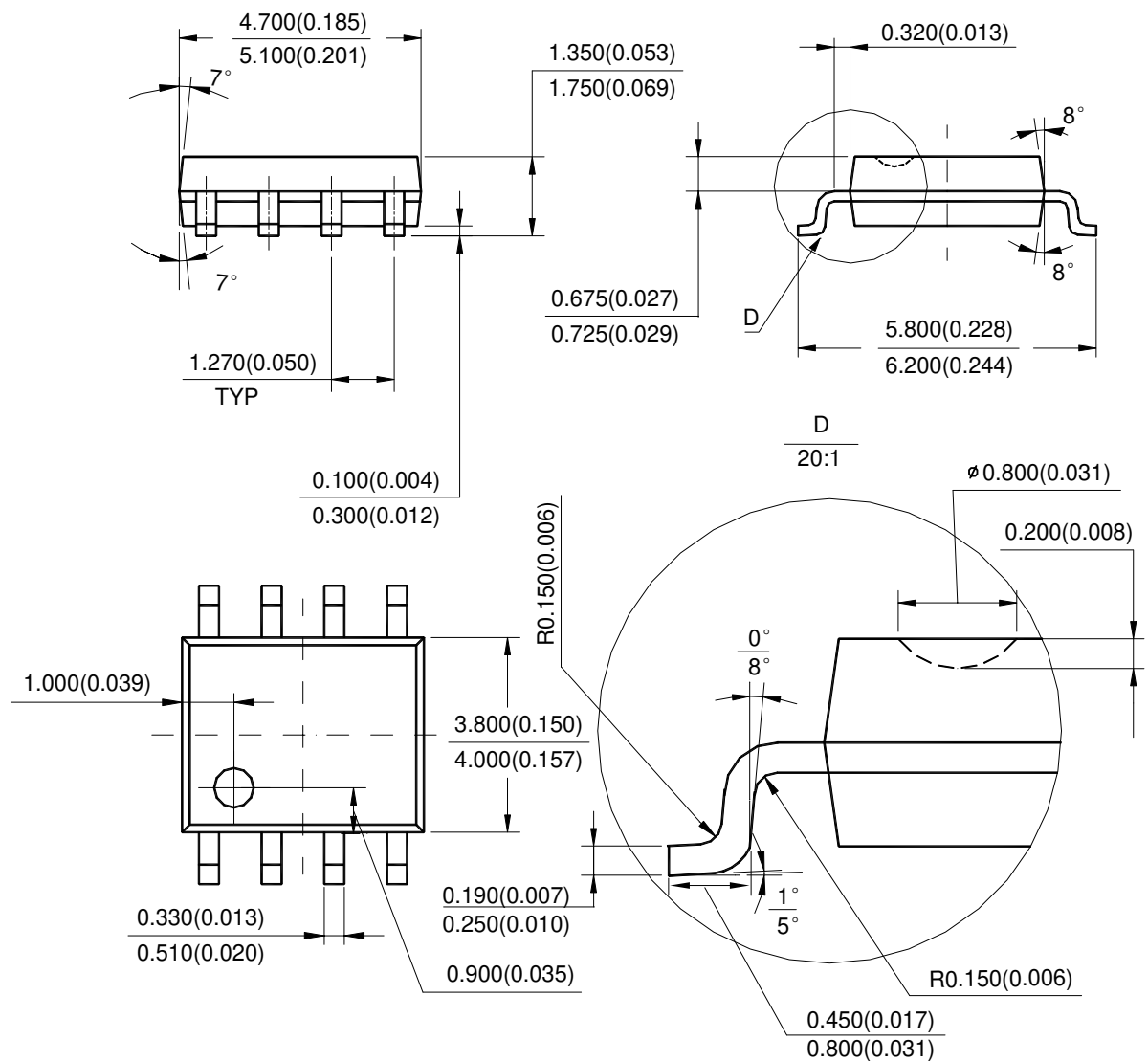

Note: Eject hole, oriented hole and mold mark is optional.

Mechanical Dimensions (Continued)

PSOP-8

Unit: mm(inch)

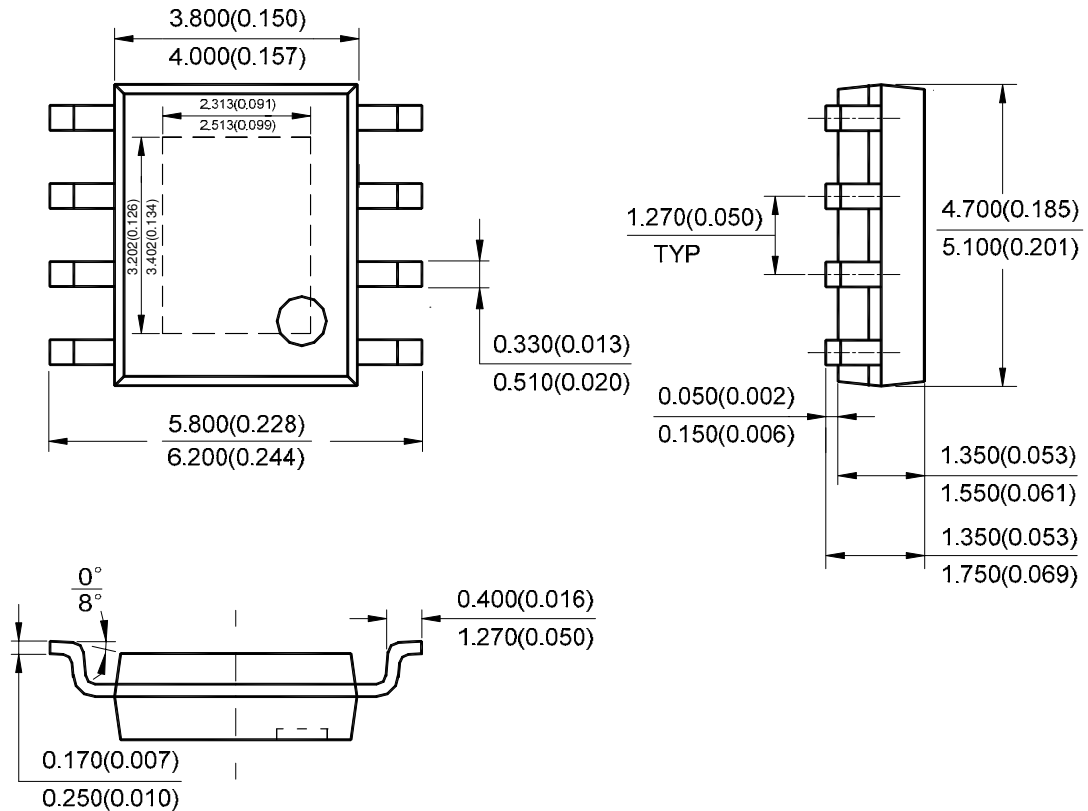

Note: Eject hole, oriented hole and mold mark is optional.



BCD Semiconductor Manufacturing Limited

<http://www.bcdsemi.com>

IMPORTANT NOTICE

BCD Semiconductor Manufacturing Limited reserves the right to make changes without further notice to any products or specifications herein. BCD Semiconductor Manufacturing Limited does not assume any responsibility for use of any its products for any particular purpose, nor does BCD Semiconductor Manufacturing Limited assume any liability arising out of the application or use of any its products or circuits. BCD Semiconductor Manufacturing Limited does not convey any license under its patent rights or other rights nor the rights of others.

MAIN SITE

- Headquarters

BCD (Shanghai) Micro-electronics Limited

No. 1600, Zi Xing Road, Shanghai ZiZhu Science-based Industrial Park, 200241, P. R. C.
Tel: +86-021-2416-2266, Fax: +86-021-2416-2277

- Wafer Fab

Shanghai SIM-BCD Semiconductor Manufacturing Co., Ltd.

800 Yishan Road, Shanghai 200233, China
Tel: +021-6485-1491, Fax: +86-021-5450-0008

REGIONAL SALES OFFICE

Shenzhen Office

Shanghai SIM-BCD Semiconductor Manufacturing Co., Ltd., Shenzhen Office

Unit A Room 1203, Skyworth Bldg., Gaoxin Ave.1.S., Nanshan District
Shenzhen 518057, China
Tel: +86-0755-8660-4900, Fax: +86-0755-8660-4958

Taiwan Office (Taipei)

BCD Semiconductor (Taiwan) Company Limited

3F, No.17, Lane 171, Sec. 2, Jiu-Zong Rd., Nei-Hu Dist., Taipei(114), Taiwan, R.O.C
Tel: +886-2-2656-2808
Fax: +886-2-2656-2806/26562950

Taiwan Office (Hsinchu)

BCD Semiconductor (Taiwan) Company Limited

8F, No.176, Sec. 2, Gong-Dao 5th Road, East District
HsinChu City 300, Taiwan, R.O.C
Tel: +886-3-5160181, Fax: +886-3-5160181

USA Office

BCD Semiconductor Corp.

48460 Kato Road, Fremont, CA 94538, USA
Tel: +1-510-668-1950
Fax: +1-510-668-1990

Korea Office

BCD Semiconductor Limited Korea office.

Room 101-1112, Digital-Empire II, 486 Sin-dong,
Yeongtong-Gu, Suwon-city, Gyeonggi-do, Korea
Tel: +82-31-695-8430