

REVISIONS				
P	LTR	DESCRIPTION	DATE	BY
AV3	REVISED PER	ECR-16-009296	28JUN2016	BW RS

- 1 BRASS PER QQ-B-626.
- 2 BERYLLIUM COPPER PER ASTM-B-196
- 3 NYLON PER ASTM-D-4066, BLACK
- 4 POLYMETHYLPENTENE GENERAL PURPOSE, NATURAL
- 5 0.00076[.000030] MINIMUM GOLD PER MIL-G-45204.
- 6 0.00254[.000100] MINIMUM GOLD PER MIL-G-45204.
- 7 SHIELDED CABLE #26=NAS-702 CLASS A & C, AND MIL-W-16878 TYPES E & EE, SHIELDED CABLE #24=NAS-702 CLASS A & C, AND MIL-W-16878 TYPES E & EE, SHIELDED CABLE #22=NAS-702 CLASS C, AND MIL-W-16878 TYPE E, AND MIL-C-7078A TYPE I NUMBER 1 DIELECTRIC .068 O.D.
- 8 RG-174/U, RG-179A/U, RG-187/U, AND 21-598.
- 9 SHIELDED CABLE #26=NAS-702 CLASS A, AND MIL-C-7078A TYPE II.
- 10. SEE IS 408-1770
- 11 NYLON PER ASTM-D-4066, NATURAL
- 12 OBSOLETE PARTS: OBSOLETE CIS STREAMLINING PER D.RENAUD/D.SINISI

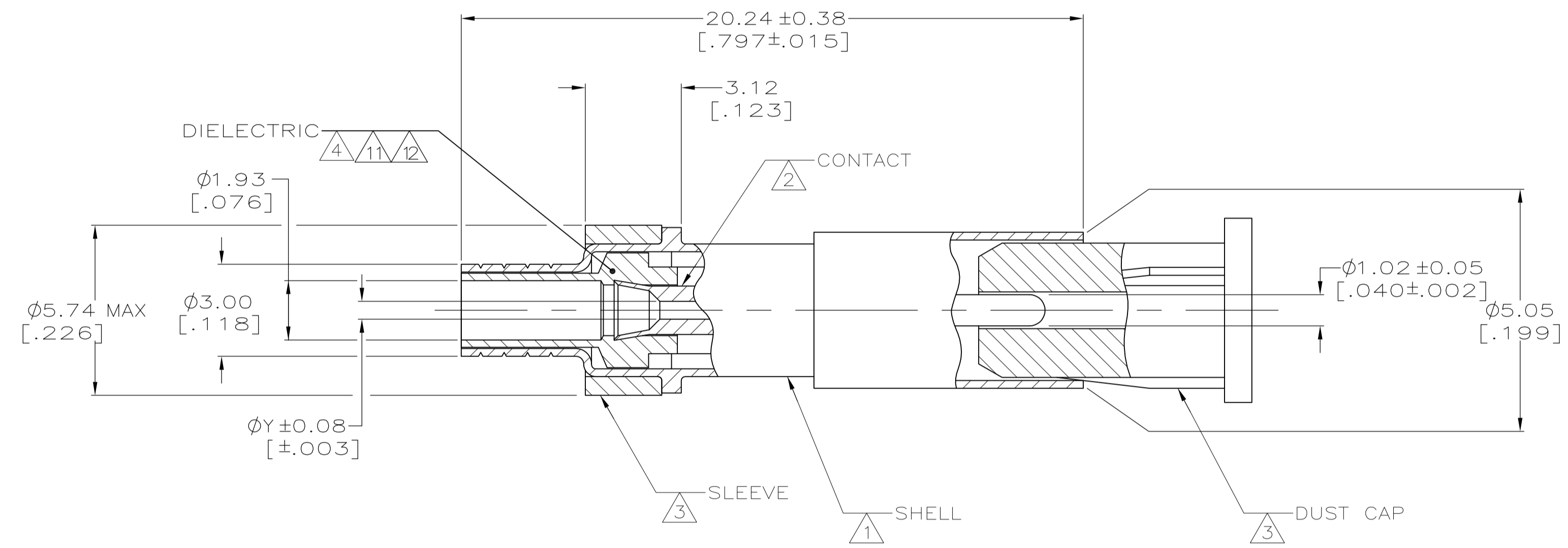

OBSOLETE	5	5	.034 OUNCES	-	-	0.81[.032]	-	-	-	1-201144-8
	-	-	1.65 GRAMS MAX	8	45368-2	-	9-328666-3	201142-2	201144-1	1-201144-1
OBSOLETE	6	6	.034 OUNCES	-	-	0.81[.032]	-	-	-	201144-7
OBSOLETE	6	6	.034 OUNCES	-	-	0.58[.023]	-	-	-	201144-6
	5	5	.034 OUNCES	-	-	0.81[.032]	-	-	-	201144-5
	5	5	.034 OUNCES	-	-	1.07[.042]	-	-	-	201144-3
	6	6	.034 OUNCES	-	-	0.58[.023]	-	-	-	201144-1
CONTACT PLATING	SHELL PLATING	WEIGHT	CABLE OR WIRE SIZE	CRIMP TOOL	Y	3 FERRULE QTY=1	2 SPRING RETENTION QTY=1	1 SOCKET ASSY QTY=1	PART NUMBER	

THIS DRAWING IS A CONTROLLED DOCUMENT.

DIMENSIONS: mm [INCHES]	TOLERANCES UNLESS OTHERWISE SPECIFIED:	DIN J. LIPPERT 18 DEC 89	STE TE Connectivity
0 PLC ± -	1 PLC ± -	22 FEB 90	NAME: SOCKET, MINIATURE SERIES
2 PLC ± -	3 PLC ± 0.20(.008)	APPROVED: B. ADAMS 22 FEB 90	PRODUCT SPEC: 108-12021
4 PLC ± -	ANGLES ± -	APPLICATION SPEC: -	SIZE: A1
MATERIAL: -	FINISH: -	WEIGHT: 0	CAGE CODE: 00779
		DRAWING NO: 201144	RESTRICTED TO: -
		CUSTOMER DRAWING	SCALE: 8:1 SHEET 1 OF 1 REV AV3