

E14  
Z14



# e-chain system® E-Z chain Series E14/Z14



### Price Index



Series E14/Z14

### Special Features / Options



IPA Qualification Certificate  
Air Cleanliness Class ISO Class 2  
(at v = 3.28 ft/s) upon request



Flammability Class  
VDE 0304 IIC UL94 V2



IPA Qualification Certificate: ESD  
Classification Level 1 (for Series  
E14-3-038). Special equipment:  
Electrically conductive ESD/ATEX  
version upon request

### Assembly Tips

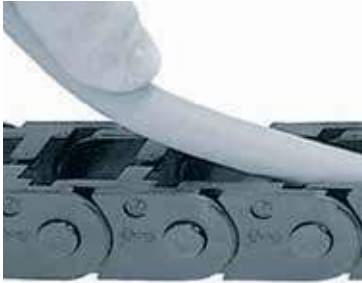

Just push the cables into the e-chain  
using your thumb

### Usage Guidelines



- If filling is required without opening and closing
- If price is an issue
- If quiet operation is required



- "Z" Series is unsuitable for gliding applications  
➤ **Series B15 E2 Mini**
- If a long unsupported length is required  
➤ **Series B15 E2 Mini**

### Features & Benefits

- 1 Small pitch for low-noise and smooth operation
- 2 Cable-friendly interior
- 3 Limited torsion tolerance
- 4 Very easy to fill
- 5 Integrated strain relief option
- 6 Patented push button design holds the links together
- 7 "E" Series features split crossbar along the outer radius
- 8 "Z" Series features split crossbar along the inner radius



### Order Example: Complete e-chain®

Please indicate chain length or number of links. Example:

3.28 ft (1 m) **E14-3-038-0**

**e-chain®**

1 Set **114-3-12PZ**

**Mounting Bracket**

# e-chain system® E-Z chain Series E14/Z14 Installation Dimensions



E14  
Z14

## Short travel, unsupported length

- $FL_B$  = unsupported with permitted sag
  - $FL_G$  = unsupported with straight upper run
- Further information ► Design, Chapter 1

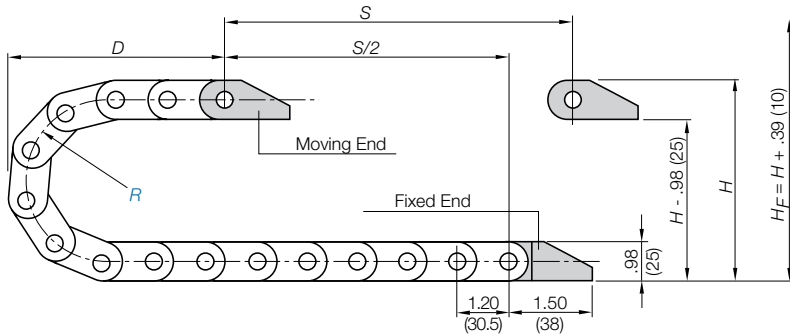
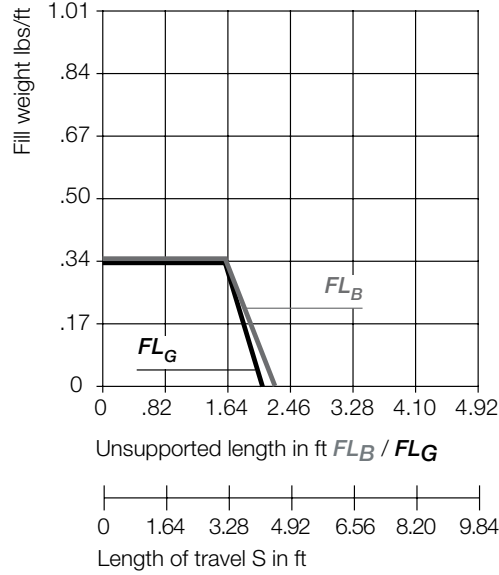
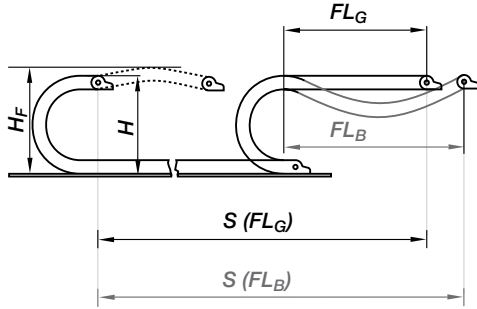

Pitch per link = 1.20" (30.5 mm)  
Links per ft (m) = 10.06 (33)  
For center mount applications:  
Chain length =  $\frac{S}{2} + K$

The required clearance height:  $H_F = H + .39$  in. (10 mm) (with .13 lbs/ft (0.2 kg/m) fill weight). Please consult igus® if space is particularly restricted.

R	1.10 (028)	1.50 (038)	1.89 (048)	2.95 (075)	3.94 (100)	4.92 (125)
H	3.19 (81)	3.98 (101)	4.76 (121)	6.89 (175)	8.86 (225)	10.83 (275)
D	3.35 (86)	3.78 (96)	4.17 (106)	5.24 (133)	6.22 (158)	7.20 (183)
K	5.91 (150)	7.28 (185)	8.46 (215)	11.81 (300)	14.96 (380)	17.91 (455)

## Short Travels - Unsupported



Unsupported E-Chains® feature positive camber over short travels. This must be accounted for when specifying the clearance height. Please refer to **Installation dimensions** for further details.

## Legend

- S = Length of travel
- R = Bending radius
- H = Nominal clearance height
- D = Overlength e-chain® radius in final position
- $K = \pi \cdot R + \text{safety buffer}$
- $H_F$  = Required clearance height



PDF: [igus.com/e-chain-pdfs](https://igus.com/e-chain-pdfs)  
Product information: [igus.com/e-chains](https://igus.com/e-chains)



Speed / acceleration $FL_G$	max. 65.6 ft/s (20 m/s) / max. 656 ft/s <sup>2</sup> (200 m/s <sup>2</sup> )
Speed / acceleration $FL_B$	max. 9.84 ft/s (3 m/s) / max. 19.69 ft/s <sup>2</sup> (6 m/s <sup>2</sup> )
Gliding speed / acceleration (maximum)	max. 9.84 ft/s (3 m/s) / max. 32.8 ft/s <sup>2</sup> (10 m/s <sup>2</sup> )
Material (e-chain®) - permitted temperature	igumid NB / -40°F (-40°C) up to +176°F (+80°C)
Material (mounting brackets)* - permitted temperature	igumid G / -40°F (-40°C) up to +248°F (+120°C)
Flammability Class (e-chain®), igumid NB	VDE 0304 IIC UL94 V2
Flammability Class (mounting brackets), igumid G*	VDE 0304 IIC UL94 HB

\*Available in igumid NB upon request, please consult igus® for delivery time

## Technical Data



Details of material properties

► Chapter 1

E14  
Z14



e-chain system® E-Z chain  
Series E14/Z14

igus®  
e-chain system®

Series E14 - Split crossbar along the outer radius

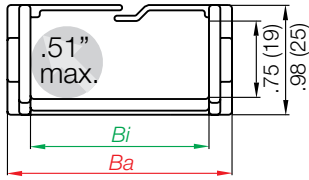

Part Number Structure

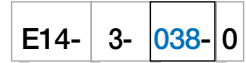

Color - Black  
Bending radius  
Width  
Series



Series Z14 - Split crossbar along the inner radius

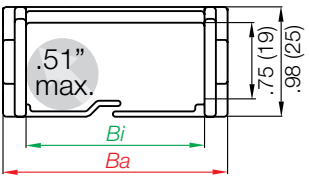

Part Number Structure



Color - Black  
Bending radius  
Width  
Series



Telephone 1-800-521-2747

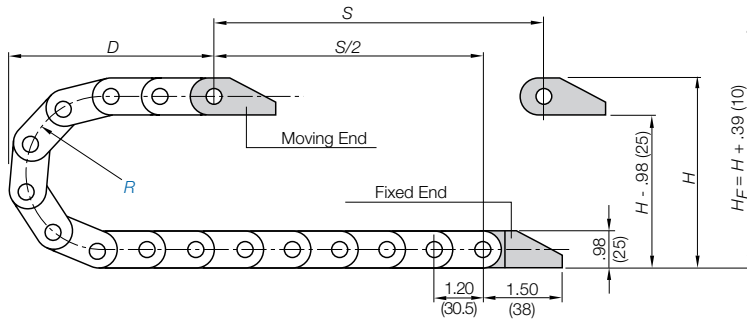

Supplement part number with required radius. Example: E14-3--0

Pitch: 1.20 in. (30.5 mm) per link links/ft (m) = 10.06 (33)

Part Number

Split Crossbar	Split Crossbar			Bi	Ba	Weight
Outer Radius	Inner Radius			in. (mm)	in. (mm)	lbs/ft (kg/m)
E14-1-	Z14-1-	<input type="text" value=""/>	-0	.59 (15)	1.06 (27)	≈ 0.21 (0.31)
E14-2-	Z14-2-	<input type="text" value=""/>	-0	.98 (25)	1.46 (37)	≈ 0.22 (0.32)
E14-3-	Z14-3-	<input type="text" value=""/>	-0	1.50 (38)	1.97 (50)	≈ 0.27 (0.40)
E14-4-	Z14-4-	<input type="text" value=""/>	-0	1.97 (50)	2.44 (62)	≈ 0.30 (0.44)

Choose from the radii below for all of the above sizes  
Radius (mm) Example: E14-3--0

	<input type="text" value="028"/>	<input type="text" value="038"/>	<input type="text" value="048"/>	<input type="text" value="075"/>	<input type="text" value="100"/>	<input type="text" value="125"/>
R	1.10 (028)	1.50 (038)	1.89 (048)	2.95 (075)	3.94 (100)	4.92 (125)
H	3.19 (81)	3.98 (101)	4.76 (121)	6.89 (175)	8.86 (225)	10.83 (275)
D	3.35 (86)	3.78 (96)	4.17 (106)	5.24 (133)	6.22 (158)	7.20 (183)
K	5.91 (150)	7.28 (185)	8.46 (215)	11.81 (300)	14.96 (380)	17.91 (455)

0=Standard color black. For other colors see Chapter 1

Internet: [igus.com](http://igus.com)  
email: [sales@igus.com](mailto:sales@igus.com)  
QuickSpec: [igus.com/quickspec](http://igus.com/quickspec)

# e-chain system® E-Z chain Series E14/Z14 Mounting Brackets



E14  
Z14



## Plastic, one-piece

- One-piece mounting bracket
- Corrosion resistant
- Available preassembled
- Inner and outer attachment possible
- Available with or without strain relief tiewrap plates

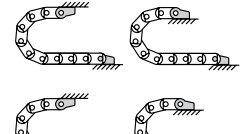
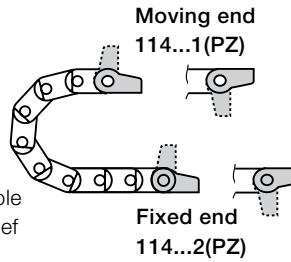

Possible installation configurations -

## Dimensions and order configurations

Strain relief is possible on the moving end and/or the fixed end.

### Part Number Structure

114-	20-	12	P	PZ
------	-----	----	---	----

- With assembled strain relief tiewrap plates
- Without assembled strain relief tiewrap plates
- Complete Set
- Width
- Mounting brackets for selected chain type

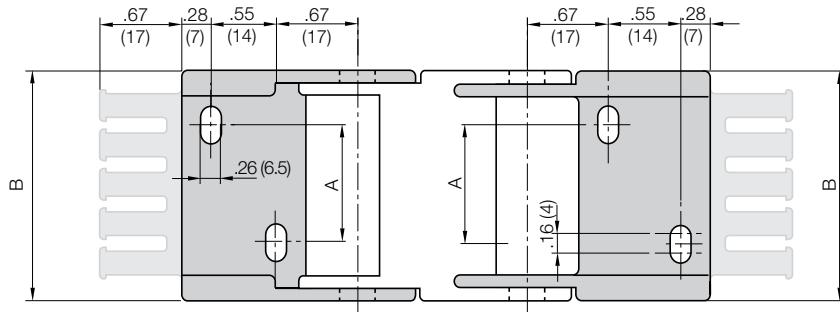

Full set, for both ends:

114- 20- 12 PZ

Full set, each part with pin/bore + tiewrap plate

Single-part order:

114- 20- 1 PZ

Mounting bracket with bore + tiewrap plate

114- 20- 2 PZ

Mounting bracket with pin + tiewrap plate

Chain Type	Part No.	Part No.	Dimension A		Dimensions B		Number of Teeth
	Full set with Tiewrap Plate	Full Set without Tiewrap Plate	in.	(mm)	in.	(mm)	
E14/Z14-1	114-1-12PZ	114-1-12P	—	—	1.04	(26.3)	2
E14/Z14-2	114-2-12PZ	114-2-12P	.39	(10)	1.43	(36.3)	3
E14/Z14-3	114-3-12PZ	114-3-12P	.91	(23)	1.94	(49.3)	4
E14/Z14-4	114-4-12PZ	114-4-12P	1.38	(35)	2.41	(61.3)	5

## Additional Accessories



**Quickfix** - mounting bracket with dowel, upon request

Part No.  
114-3-12QZ

PDF: [igus.com/e-chain-pdfs](http://igus.com/e-chain-pdfs)  
Product information: [igus.com/e-chains](http://igus.com/e-chains)

