

LEGEND MODEL

TOP END OF SWITCH

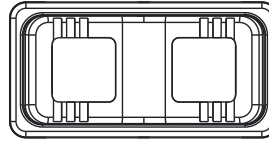

POS 1 POS 2 POS 3

DRAWING FILE NO. V452U811-14400-000		REV 01-03-23
REVISIONS		
DATE	DESCRIPTION	
01-03-23	DRAWING CREATED	

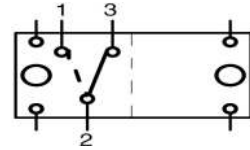

CIRCUIT DIAGRAM

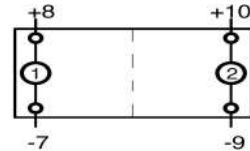
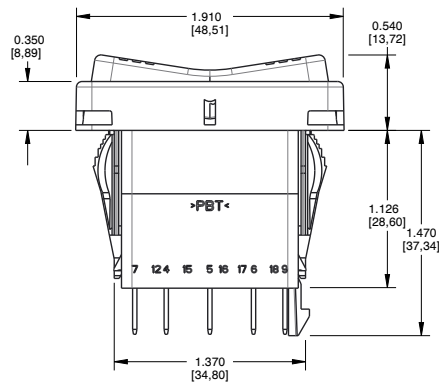
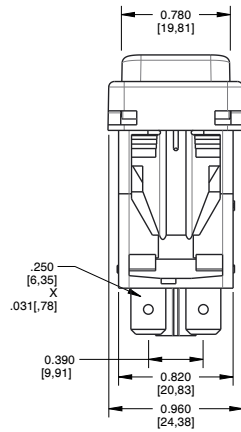

LAMP CIRCUIT DIAGRAM

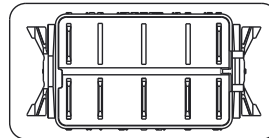

	60 JOHNSON AVE. PLAINVILLE, CT 06062, USA PHONE: (860) 793-5281 SALES: SALES@CARLINGTECH.COM APPLICATION SUPPORT: TEAM2@CARLINGTECH.COM
	V-SERIES SEALED ROCKER SWITCH
	DO NOT SCALE DRAWING UNLESS OTHERWISE SPECIFIED DIMENSIONS: IN [MM] TOLERANCES: ± .020 [0.51]
	DRAWING FILE NO. V452U811-14400-000

<p>PROPRIETARY NOTICE NOTICE TO ALL PERSONS RECEIVING THIS DRAWING: THIS DOCUMENT IS THE PROPERTY OF CARLING TECHNOLOGIES, INC. AND IS NOT TO BE DISCLOSED, REPRODUCED IN WHOLE OR IN PART OR USED FOR MANUFACTURING PURPOSES BY ANYONE WITHOUT THE CONSENT OF CARLING TECHNOLOGIES, INC.</p>
<p>DISCLAIMER MANUFACTURER RESERVES THE RIGHT TO CHANGE PRODUCT SPECIFICATIONS WITHOUT PRIOR NOTICE.</p>
<p>DRAWING FILE NO. V452U811-14400-000</p>
<p>SIZE C</p>
<p>PRODUCT SERIES: V-Ser. Switch</p>

<p>PROPRIETARY NOTICE NOTICE TO ALL PERSONS RECEIVING THIS DRAWING: THIS DOCUMENT IS THE PROPERTY OF CARLING TECHNOLOGIES, INC. AND IS NOT TO BE DISCLOSED, REPRODUCED IN WHOLE OR IN PART OR USED FOR MANUFACTURING PURPOSES BY ANYONE WITHOUT THE CONSENT OF CARLING TECHNOLOGIES, INC.</p>
<p>DISCLAIMER MANUFACTURER RESERVES THE RIGHT TO CHANGE PRODUCT SPECIFICATIONS WITHOUT PRIOR NOTICE.</p>
<p>DRAWING FILE NO. V452U811-14400-000</p>
<p>SIZE C</p>
<p>PRODUCT SERIES: V-Ser. Switch</p>

CONTURA X & XI ROCKER SWITCH SERIES
 SINGLE POLE: ON-NONE-ON
 RATING: 10A 250VAC 1/2 HP; 15A 125VAC 1/2 HP UL/CSA
 10 TERM BASE; .250" TABS; NO BARRIERS ON BASE; NO JUMPERS
 SEALED - LAMPS 1 & 2 INDEPENDENT
 LAMP 1 - INCANDESCENT 24V
 LAMP 2 - NEON 125VAC
 BLACK RAISED BRACKET; NO GASKETS
 CONTURA X, BLACK ACTUATOR
 OVER LAMP 1, CLEAR SQUARE LENS
 OVER LAMP 2, CLEAR SQUARE LENS
 NO LEGEND IN FIRST LOCATION (LAMP 1)
 NO LEGEND IN SECOND LOCATION (LAMP #2)

DRAWING FILE NO.		REV
V452U811-14400-000		01-03-23
REVISIONS		
DATE	DESCRIPTION	
01-03-23	DRAWING CREATED	

Carling Technologies
 Innovative Design. Proven Solutions.
 60 JOHNSON AVE.
 PLAINVILLE, CT 06062, USA
 PHONE: (860) 793-5281
 SALES: SALES@CARLINGTECH.COM
 APPLICATION SUPPORT: TEAM2@CARLINGTECH.COM

PROPRIETARY NOTICE
 NOTICE TO ALL PERSONS RECEIVING THIS DRAWING: THIS DOCUMENT IS THE PROPERTY OF CARLING TECHNOLOGIES, INC. AND IS NOT TO BE DISCLOSED, REPRODUCED IN WHOLE OR IN PART OR USED FOR MANUFACTURING PURPOSES BY ANYONE WITHOUT THE CONSENT OF CARLING TECHNOLOGIES, INC.
DISCLAIMER
 MANUFACTURER RESERVES THE RIGHT TO CHANGE PRODUCT SPECIFICATIONS WITHOUT PRIOR NOTICE.

V-SERIES
SEALED ROCKER SWITCH
 DO NOT SCALE DRAWING
 UNLESS OTHERWISE SPECIFIED
 DIMENSIONS: IN (MM)
 TOLERANCES: ± .020 (0.51)
 DRAWING FILE NO.
 V452U811-14400-000
 PRODUCT SERIES: V-Ser. Switch
 SIZE
 C
 SHEET 2 OF 2