

MYC-AM335X CPU Module Overview

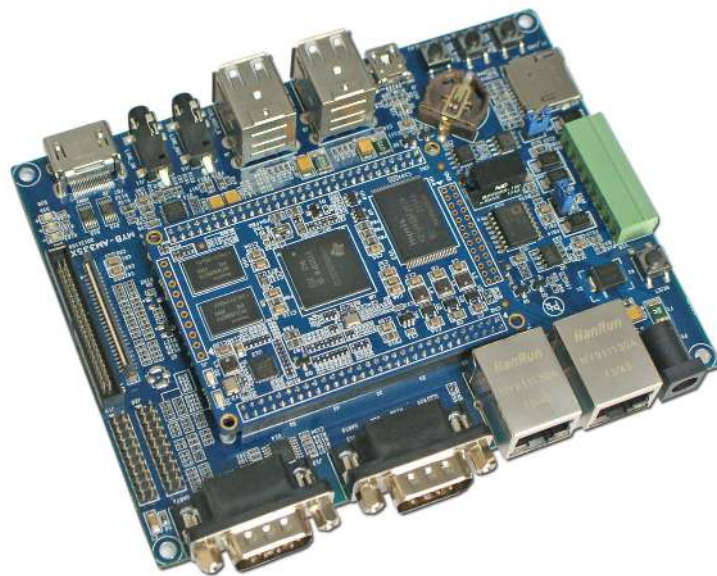

- ✓ *Up to 1GHz TI AM335x Series ARM Cortex-A8 Processors*
- ✓ *512MB (2*256MB) DDR3 SDRAM, 512MB Nand Flash*
- ✓ *On-board Gigabit Ethernet PHY*
- ✓ *Two 2.0mm pitch 60-pin Male Expansion Connectors*
- ✓ *Ready to Run Linux 4.1.18*
- ✓ *Supports -40 to +85 Celsius Extended Temperature Operation for Industrial Applications*



Measuring only 70mm by 50mm, the MYC-AM335X is a highly-integrated low-cost ARM embedded SOM (System on Module) supporting up to 1GHz Sitara AM335x (AM3352, AM3354, AM3356, AM3357, AM3358 and AM3359) ARM Cortex-A8 processors from Texas Instruments (TI), featuring PowerVR™ SGX530 for 2D and 3D graphics acceleration as well as PRU/ICSS supporting real-time protocols such as EtherCAT, PROFINET, EtherNet/IP, PROFIBUS, Ethernet Powerlink, Sercos, and others.

The MYC-AM335X CPU Module has integrated the AM335x processor, 512MB DDR3 SDRAM, 512MB Nand Flash and Gigabit Ethernet PHY chip on board and can be served as the core of your embedded system. It has two 2.0mm pitch 60-pin male expansion connectors for interconnecting with your base board, thus providing an interface for the base board to carry most of the I/O signals to and from the CPU module. One 2.0mm pitch 26-pin interface and one 2.54mm pitch 10-pin interface are also designed with only reserved solder joints which have extended a few signals for some special purpose.

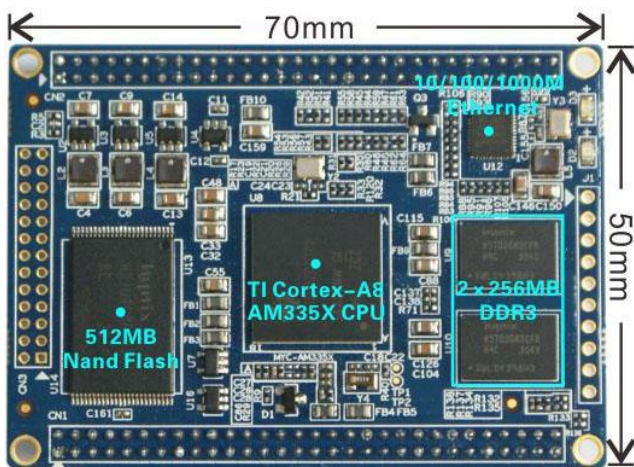

MYC-AM335X Top-view

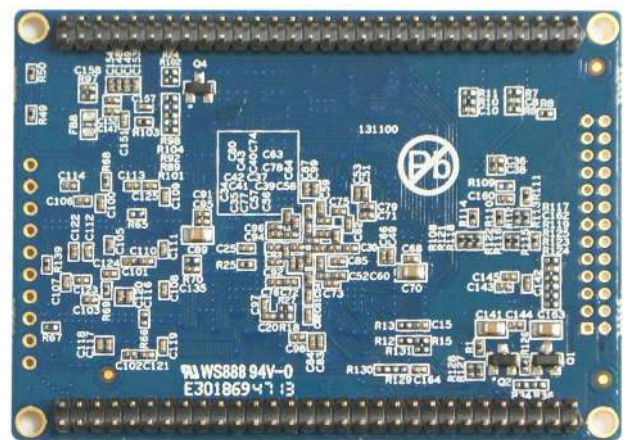

MYC-AM335X Bottom-view

The MYC-AM335X CPU Module series have six models with different AM335x processors. They are sharing the same pin-out with software fully compatible. MYIR delivers the **MYC-AM3352** and **MYC-AM3358** by default according to customer's specified model. Other four models are only available for mass quantity demand.

- MYC-AM3352 CPU Module for TI AM3352
- MYC-AM3354 CPU Module for TI AM3354
- MYC-AM3356 CPU Module for TI AM3356
- MYC-AM3357 CPU Module for TI AM3357
- MYC-AM3358 CPU Module for TI AM3358
- MYC-AM3359 CPU Module for TI AM3359

You can get to know the main differences of the six Sitara ARM Cortex-A8 processors from below image.



	ARM Cortex-A8 (MHz)	Graphics	PRU-ICSS for Slave Industrial Communications	Package	Availability
AM3359	800	3D graphics	PRU-ICSS + EtherCAT slave	15x15 / 0.8mm	In Production
AM3358	600/800/1000	3D graphics	PRU-ICSS	15x15 / 0.8mm	In Production
AM3357	300/600/800		PRU-ICSS + EtherCAT slave	15x15 / 0.8mm	In Production
AM3356	300/600/800		PRU-ICSS	15x15 / 0.8mm	In Production
AM3354	600/800/1000	3D graphics		15x15 / 0.8mm 13x13 / 0.65mm*	In Production
AM3352	300/600/800/1000			15x15 / 0.8mm 13x13 / 0.65mm*	In Production

✓ PRU-ICSS is used for slave industrial communication protocols such as Profibus, Profinet, Powerlink & Ethernet/IP

Package	15x15mm (ZCZ)
ARM speed	Up to 1000 MHz
USB 2.0 OTG + PHY	x2
EMAC	2-port switch

AM335x Devices Comparison

The MYC-AM335X is the core of the MYD-AM335X development board which is a full-featured evaluation platform for users developing applications with Linux. Many peripheral interfaces such as two serial ports, four USB Host ports, one USB OTG port, dual Gigabit Ethernet ports, one CAN, one RS485, one Micro SD, HDMI, LCD, Touch screen have been carried out by headers and connectors on the base board. It can work in harsh environment supporting -40 to +85 Celsius extended temperature operation and make it ideal for industrial embedded applications such as automotive, control systems, lighting, refining and processing.

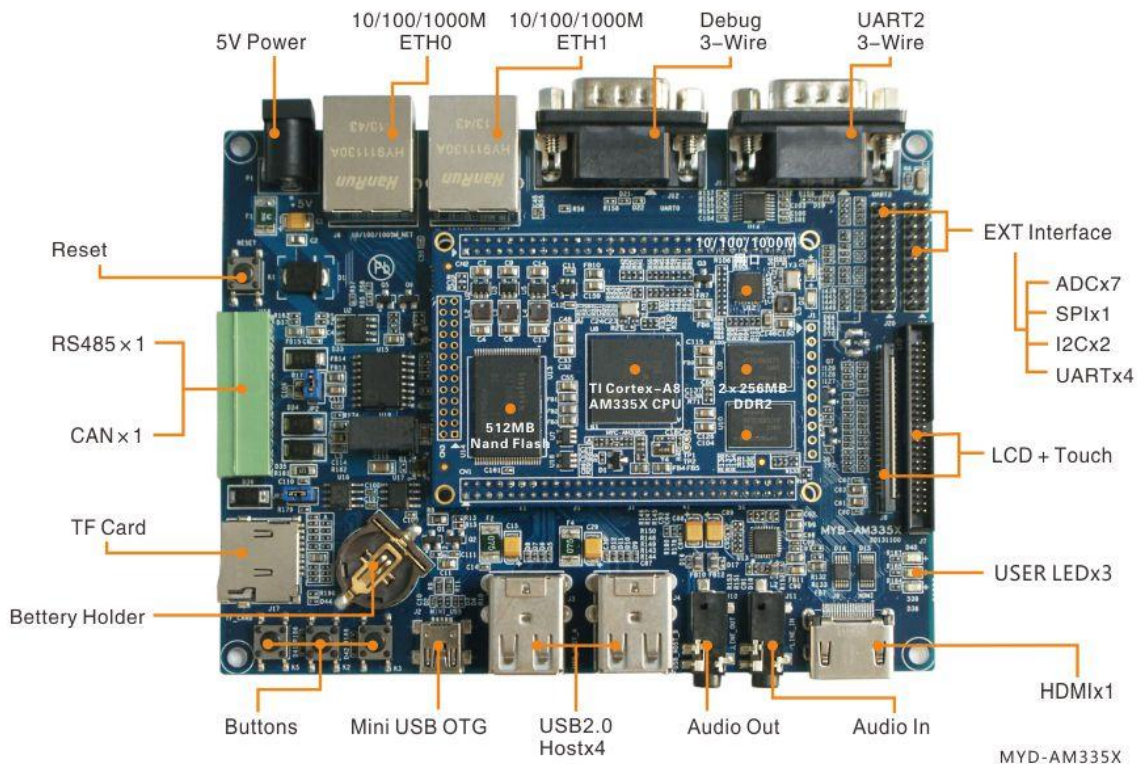

MYD-AM335X Development Board



Hardware Specification

The [TIAM335x](#) microprocessors, based on the ARM Cortex-A8, operating at up to 1GHz, are enhanced with image, graphics processing, peripherals and industrial interface options such as EtherCAT and PROFIBUS. The device supports the following high-level operating systems (HLOSs) that are available free of charge from TI:

- Linux®
- Android™

The AM335x microprocessor contains these subsystems:

- Microprocessor unit (MPU) subsystem based on the ARM Cortex-A8 microprocessor.
- POWERVR SGX™ Graphics Accelerator subsystem for 3D graphics acceleration to support display and gaming effects.
- The Programmable Real-Time Unit and Industrial Communication Subsystem (PRU-ICSS) is separate from the ARM core, allowing independent operation and clocking for greater efficiency and flexibility. The PRU-ICSS enables additional peripheral interfaces and real-time protocols such as EtherCAT, PROFINET, EtherNet/IP, PROFIBUS, Ethernet Powerlink, Sercos, and others.

AM335x ARM Cortex™-A8 Processors						
Core Feature	AM3352	AM3354	AM3356	AM3357	AM3358	AM3359
Package	15x15mm, 0.8mm (ZCZ)					
CPU Speed (MHz)	300, 600, 800, 1000	600, 800,1000	300, 600,800	300, 600,800	600, 800,1000	800
Core Internal Memory	64KB SRAM shared w/ Data 32KB Cache, Programmable 32KB Cache					
On-chip L2 (KB)	256					
External Memory Interface	DDR2/DDR3/DDR3L/mDDR (LPDDR), 2x16-bit, NAND ECC					
Graphics	-	3D Graphics	-	-	3D Graphics	
OS Support	Linux, Android, RTOS, Windows Embedded, no-OS					
Other Hardware Acceleration	Crypto Accelerator	Crypto Accelerator	2 PRU-ICSS Crypto Accelerator	2 PRU-ICSS Crypto Accelerator + EtherCAT slave support	2 PRU-ICSS Crypto Accelerator	2 PRU-ICSS Crypto Accelerator + EtherCAT slave support
10/100/1000 EMAC	2 port switch					
USB 2.0 OTG + PHY	2					
Serial Ports	6 UART, 2 SPI, 3 I2C, 2 McASP, 2 CAN, 8 Timers					
System	EDMA, WDT, RTC, 3 eQEP, 3 eCAP, JTAG, ADC (8ch)					
Parallel	3 MMC/SD/SDIO, GPIO					

AM335x Devices Key Features

**Mechanical Parameters**

- Dimensions: 70mm x 50mm
- PCB Layers: 8-layer design
- Power supply: +3.3V/0.8A
- Working temperature: 0~70 Celsius (commercial grade) or -40~85 Celsius (industrial grade)

Processor

- TI AM3352, AM3354, AM3356, AM3357, AM3358, AM3359
 - Up to 1GHz ARM Cortex-A8 32-bit RISC MPU
 - NEON™ SIMD Coprocessor
 - 32KB/32KB of L1 Instruction/Data Cache with Single-Error Detection (parity)
 - 256KB of L2 Cache with Error Correcting Code (ECC)
 - SGX530 Graphics Engine
 - Programmable Real-Time Unit Subsystem

Memory

- 512MB DDR3 SDRAM
- 512MB Nand Flash

Peripherals and Signals Routed to Pins

- On-board Gigabit Ethernet PHY
- One power indicator (Red LED)
- One user LED (Green)
- Two 2.0mm pitch 60-pin expansion connectors can carry out interfaces below
 - 2 x USB2.0 OTG ports
 - 6 x Serial ports
 - 2 x I2C
 - 1 x SPI
 - 7 x ADC
 - 2 x PWM
 - 3 x SDIO
- One 2.0mm pitch 26-pin expansion interface
- One 2.54mm pitch 10-pin expansion interface



Signals Routed to Expansion Connectors

The MYC-AM335X CPU Module has two 2.0mm pitch 60-pin male expansion connectors (CN1 & CN2), one 2.0mm pitch 26-pin interface (CN3) and one 2.54mm pitch 10-pin interface (CN4) to allow extension of all the controller signals and ports to the base board through headers and connectors, thus exposing more features of the AM335x Cortex-A8 processor. Please refer to below table to know signals routed to the pins:

Function	IO Pin	CN1 Pin No.	CN1 Pin No.	IO Pin	Function
Power GND	DGND	1	2	+3V3	3V3 power
Power GND	DGND	3	4	+3V3	3V3 power
RTC power	VDD18_EXT_RTC	5	6	T18	USB1_VBUS
USB1_DRVVBUS	F15	7	8	P15	USB0_VBUS
USB0_DRVVBUS	F16	9	10	R18	USB1_DM
USB0_DM	N18	11	12	R17	USB1_DP
USB0_DP	N17	13	14	P16	USB0_ID
USB1_ID	P17	15	16	C17	I2C0_SDA
I2C0_SCL	C16	17	18	DGND	Power GND
MMC0_CLK	G17	19	20	G18	MMC0_CMD
MMC0_DAT0	G16	21	22	G15	MMC0_DAT1
MMC0_DAT2	F18	23	24	F17	MMC0_DAT3
GPIO3_21	A14	25	26	H18	UART5_TX
UART5_RX	H16	27	28	J15	UART2_TX
UART2_RX	H17	29	30	E17	UART4_TX
UART4_RX	E18	31	32	E16	UART0_TX
UART0_RX	E15	33	34	D15	UART1_TX
UART1_RX	D16	35	36	C18	UART3_TX
UART3_RX	C15	37	38	D18	DCAN0_TX
DCAN0_RX	D17	39	40	A17	eHRPWM0A
eHRPWM0B	B17	41	42	A16	I2C1_SCL
I2C1_SDA	B16	43	44	A13	SPI1_SCLK
SPI1_D0	B13	45	46	D12	SPI1_D1
SPI1_CS0	C12	47	48	D13	GPIO3_20
nRESETIN_OUT	A10	49	50	B18	nNMI
Power GND	DGND	51	52	A8	AIN6
AIN5	B8	53	54	C8	AIN4
AIN3	A7	55	56	B7	AIN2
AIN1	C7	57	58	B6	AIN0
ADC Ground	GND_ADC	59	60	VDD_ADC	ADC power

Pins of CN1 connector



Function	IO Pin	CN2 Pin No.	CN2 Pin No.	IO Pin	Function
MDIO_DATA	M17	1	2	M18	MDIO_CLK
RGMII2_RD0	V17	3	4	T16	RGMII2_RD1
RGMII2_RD2	U16	5	6	V16	RGMII2_RD3
RGMII2_RCLK	T15	7	8	U15	RGMII2_TCLK
RGMII2_TD0	V15	9	10	R14	RGMII2_TD1
RGMII2_TD2	T14	11	12	U14	RGMII2_TD3
RGMII2_RCTL	V14	13	14	R13	RGMII2_TCTL
Power GND	DGND	15	16	DGND	Power GND
MMC2_CLK	V12	17	18	T13	MMC2_CMD
MMC2_DAT3	U13	19	20	V13	MMC2_DAT2
MMC2_DAT1	R12	21	22	T12	MMC2_DAT0
MMC2_DAT7	U12	23	24	T11	MMC2_DAT6
MMC2_DAT5	T10	25	26	U10	MMC2_DAT4
Power GND	DGND	27	28	DGND	Power GND
LCD_AC_BIAS_EN	R6	29	30	R5	LCD_HSYNC
LCD_VSYNC	U5	31	32	V5	LCD_PCLK
LCD_DATA15	T5	33	34	V4	LCD_DATA14
LCD_DATA13	V3	35	36	V2	LCD_DATA12
LCD_DATA11	U4	37	38	U3	LCD_DATA10
LCD_DATA9	U2	39	40	U1	LCD_DATA8
LCD_DATA7	T4	41	42	T3	LCD_DATA6
LCD_DATA5	T2	43	44	T1	LCD_DATA4
LCD_DATA3	R4	45	46	R3	LCD_DATA2
LCD_DATA1	R2	47	48	R1	LCD_DATA0
Power GND	DGND	49	50	DGND	Power GND
RGMII1_TRN3	RGMII1_TRN3	51	52	RGMII1_TRP3	RGMII1_TRP3
RGMII1_TRN2	RGMII1_TRN2	53	54	RGMII1_TRP2	RGMII1_TRP2
RGMII1_TRN1	RGMII1_TRN1	55	56	RGMII1_TRP1	RGMII1_TRP1
RGMII1_TRN0	RGMII1_TRN0	57	58	RGMII1_TRP0	RGMII1_TRP0
RGMII1_LED_LINK	RGMII1_LED_LINK	59	60	RGMII1_LED_ACT	RGMII1_LED_ACT

Pins of CN2 Connector



Function	IO Pin	CN3 Pin	CN3 Pin	IO Pin	Function
3V3 Power	+3V3	1	2	DGND	Power GND
MMC1_CLK	U9	3	4	V9	MMC1_CMD
MMC1_DAT0	U7	5	6	V7	MMC1_DAT1
MMC1_DAT2	R8	7	8	T8	MMC1_DAT3
MMC1_DAT4	U8	9	10	V8	MMC1_DAT5
MMC1_DAT6	R9	11	12	T9	MMC1_DAT7
Power GND	DGND	13	14	U6	GPMC_WEN
GPMC_OEn_REn	T7	15	16	R7	GPMC_ADVn_ALE
GPMC_BEN0_CLE	T6	17	18	T17	GPMC_WAIT0
GPMC_WPN	U17	19	20	MR	MR_INn
WAKEUP	C5	21	22	A15	XDMA_EVENT_INTRO
POWR_EN	POWR_EN	23	24	C6	PWR_HOLD_1.8V
Power GND	DGND	25	26	+3V3	3V3 Power

Pins of CN3 Connector

Function	IO Pin	CN4 Pin No.	CN4 Pin No.	IO Pin	Function
3V3 power	+3V3	1	2	DGND	Power GND
JTAG_RTCK	JTAG_RTCK	3	4	B10	nTRST
TMS	C11	5	6	B11	TDI
TCK	A12	7	8	A11	TDO
EMU0	C14	9	10	B14	EMU1

Pins of CN4 Connector



Function Block Diagram

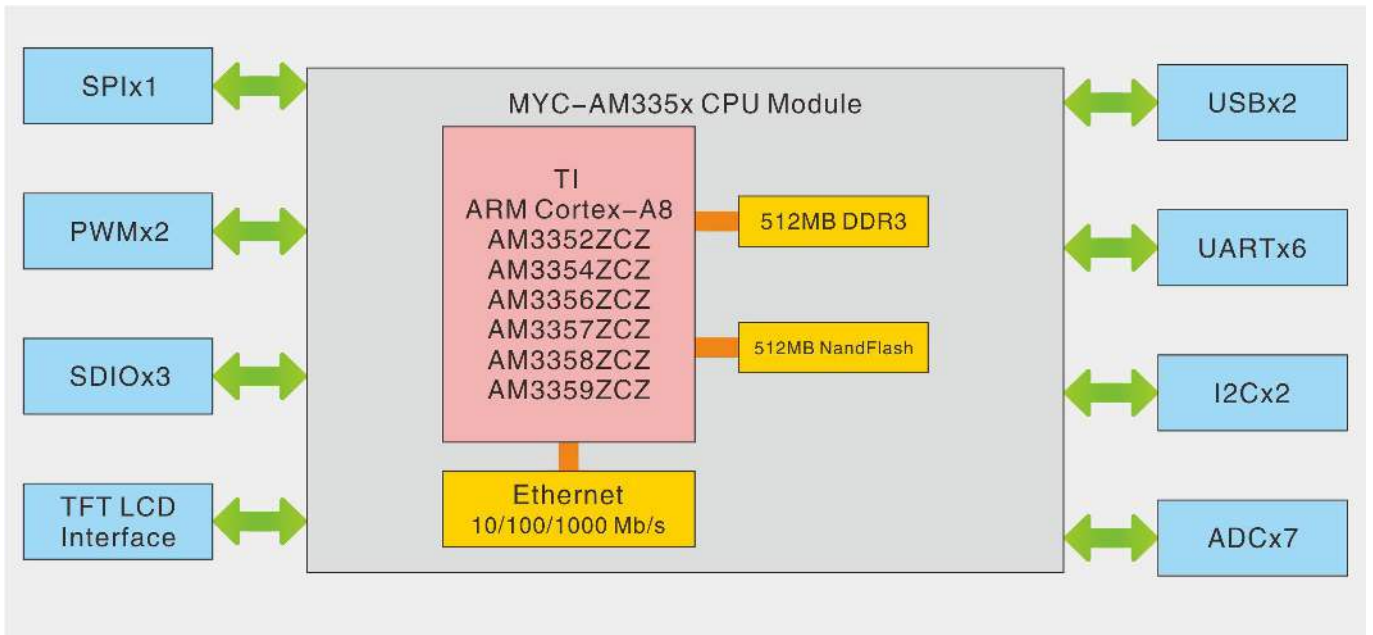

MYC-AM335X Function Block Diagram

Dimension Chart of MYC-AM335X

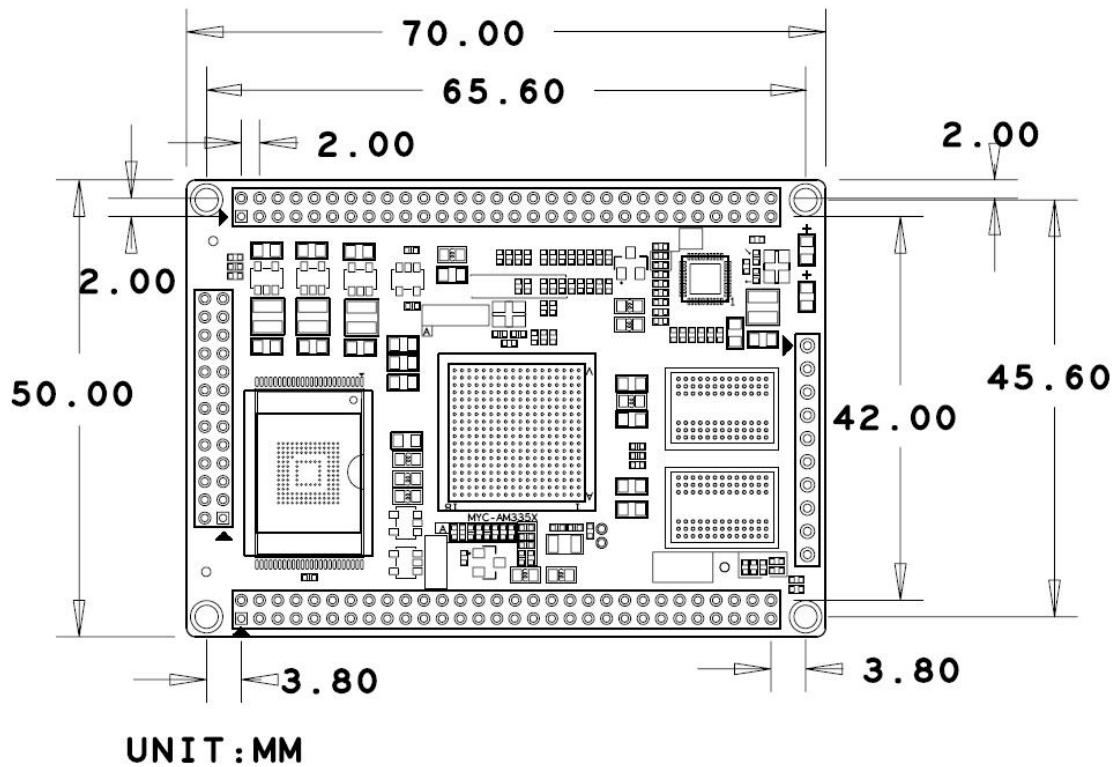

MYC-AM335X Dimension Chart



Software Features

MYIR’s MYC-AM335X CPU module supports for Linux and is provided with software packages. Many peripheral drivers are in source code to help accelerate customers’ designs with a stable and reliable hardware and software platform. The software features are summarized as below:

OS	Item	Features	Description
Linux	Bootstrap program	SPL	The primary bootstrap
		u-boot	The secondary bootstrap
	Kernel	Version	Linux 4.1.18
	Drivers	USB OTG, Gigabit Ethernet, MMC/SD/TF, NandFlash, CAN, RS485, Audio, LCD Controller (supports 4.3- and 7-inch LCD), RTC, HDMI, Touch driver, Button, UART, LED	
	File system	Buildroot With QT library (V5.6.2)	Provide image file and buildroot in source code
	Demo	Audio, CAN, EEPROM, framebuffer, gpio, keypad, led, mtd, network, rtc, RS232, RS485	

Order Information

Product Item	Part No.
MYC-AM335X CPU Module	MYC-C3352-V4-512N512D-80-C
	MYC-C3358-V4-512N512D-100-C
MYC-AM335X CPU Module	MYC-C3352-V4-512N512D-80-I
	MYC-C3358-V4-512N512D-100-I
MYC-AM335X CPU Module	MYC-C3352-V4-256N256D-80-I
	MYC-C3358-V4-256N256D-100-I
MYD-AM335X Development Board	MYD-C3352-V4-512N512D-80-C
	MYD-C3358-V4-512N512D-100-C
MYD-AM335X Development Board	MYD-C3352-V4-512N512D-80-I
	MYD-C3358-V4-512N512D-100-I
MYD-AM335X Development Board	MYD-C3352-V4-256N256D-80-I
	MYD-C3358-V4-256N256D-100-I
MY-LCD43TP 4.3-inch LCD Module with resistive touch screen	MY-TFT043RV2
MY-LCD70TP 7-inch LCD Module with resistive touch screen	MY-TFT070RV2
MY-LCD70TP-C 7-inch LCD Module with capacitive touch screen	MY-TFT070CV2
We accept custom design based on the MYC-AM335X, whether reducing, adding or modifying the existing hardware according to customer's requirement.	

MYiR Tech Limited

Headquarter Address: Room 04, 6th Floor, Building No.2, Fada Road, Yunli Smart Park, Bantian, Longgang District, Shenzhen, Guangdong, China 518129

Factory Address: Room 201, Block C, Shengjianli Industrial Park, Dafu Industrial Zone, Guanlan, Longhua District, Shenzhen, 518110, China

Website: www.myirtech.com

Email: sales@myirtech.com

Tel: +86-755-22984836