

NHD-0440AZ-FL-YBW

Character Liquid Crystal Display Module

NHD- Newhaven Display
0440- 4 Lines x 40 Characters
AZ- Model
F- Transflective
L- Yellow/Green LED Backlight
Y- STN – Yellow/Green
B- 6:00 Optimal View
W- Wide Temp.
RoHS Compliant

Newhaven Display International, Inc.

2661 Galvin Ct.

Elgin IL, 60124

Ph: 847-844-8795

Fax: 847-844-8796

www.newhavendisplay.com

nhtech@newhavendisplay.com

nhsales@newhavendisplay.com

Document Revision History

Revision	Date	Description	Changed by
0	10/21/08	Initial Release	-
1	11/2/09	User Guide Reformat	MC
2	11/16/09	Updated Block diagram and initialization code	MC
3	12/16/09	Updated Backlight Supply Current Information	MC
4	1/05/11	Updated Controller Information	JT
5	5/6/11	Electrical characteristics updated	AK
6	8/2/16	Mechanical Drawing, Electrical & Optical Char. Updated	SB
7	9/26/16	Supply Current Updated	SB
8	3/23/18	Electrical Characteristics Updated	SB

Functions and Features

- 4 lines x 40 characters
- 2 Built-in controllers (ST7066U)
- +5.0V Power Supply
- 1/16 duty, 1/5 bias
- RoHS compliant

SYMBOL	REVISION	DATE

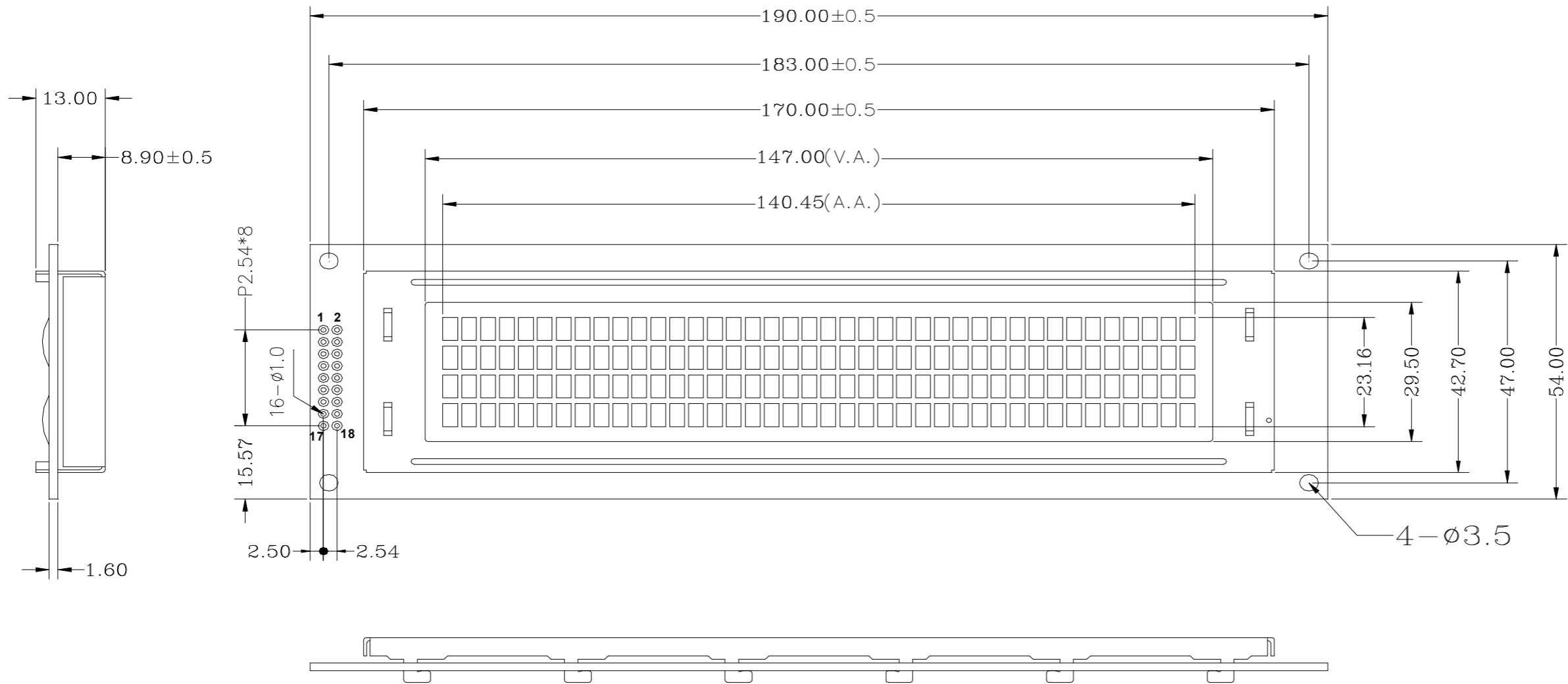

PIN ASSIGNMENT

1	DB7
2	DB6
3	DB5
4	DB4
5	DB3
6	DB2
7	DB1
8	DB0
9	E1
10	RW
11	RS
12	V0
13	VSS
14	VDD
15	E2
16	NC
17	LED+
18	LED-

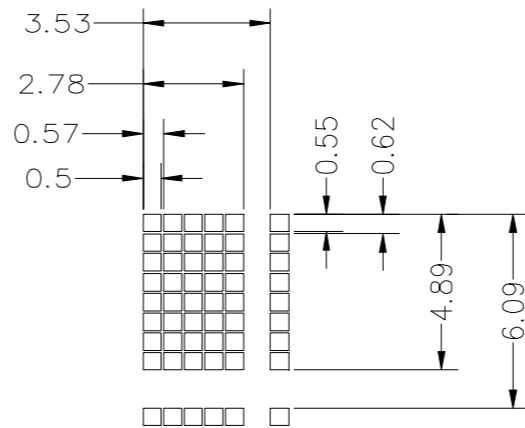

- Notes:**
1. Driver: 1/16 Duty, 1/5 Bias
 2. Voltage: 5.0V VDD, 4.3V VLCD
 3. Display Mode: STN Positive / Yellow-Green / Transflective
 4. Optimal View: 6:00
 5. Backlight: Yellow-Green LED
 6. Driver IC: ST7066U 8/4-Bit MPU Interface

STANDARD TOLERANCES (UNLESS OTHERWISE SPECIFIED) LINEAR: XX. ±0.3 mm XX.X ±0.3 mm XX.XX ±0.3 mm				DRAWING/PART NUMBER: NHD-0440AZ-FL-YBW	REVISION: 1.0
	UNLESS OTHERWISE SPECIFIED - DIMENSIONS ARE IN MILLIMETERS - THIRD ANGLE PROJECTION			DRAWN BY: S. Baxi	CHECKED BY: S. Baxi
			DRAWN DATE: 03/23/18	CHECKED DATE: 03/23/18	APPROVED DATE: 03/23/18
DO NOT SCALE DRAWING					SHEET 1 OF 1
THIS DRAWING IS SOLELY THE PROPERTY OF NEWHAVEN DISPLAY INTERNATIONAL, INC. THE INFORMATION IT CONTAINS IS NOT TO BE DISCLOSED, REPRODUCED OR COPIED IN WHOLE OR PART WITHOUT WRITTEN APPROVAL FROM NEWHAVEN DISPLAY.					

Pin Description and Wiring Diagram

Pin No.	Symbol	External Connection	Function Description
1-4	DB7-DB4	MPU	Four high order bi-directional three-state data bus lines.
5-8	DB3-DB0	MPU	Four low order bi-directional three-state data bus lines. These four are not used during 4-bit operation.
9	E1	MPU	Operation enable signal. Falling edge triggered for top 2 lines.
10	R/W	MPU	Read/Write select signal, R/W=1: Read R/W:=0: Write
11	RS	MPU	Register Select signal. RS=0: Command, RS=1: Data
12	V ₀	Power Supply	Supply Voltage for contrast (approx. 0.5V)
13	V _{SS}	Power Supply	Ground
14	V _{DD}	Power Supply	Supply Voltage for logic (+5.0V)
15	E2	MPU	Operation Enable signal. Falling edge triggered for bottom 2 lines.
16	NC	-	No Connect
17	LED+	Power Supply	Backlight Anode (+5.0V via on board resistor)
18	LED-	Power Supply	Backlight Cathode (Ground)

Recommended LCD connector: 2.54mm pitch pins

Backlight connector: --- **Mates with:** ---

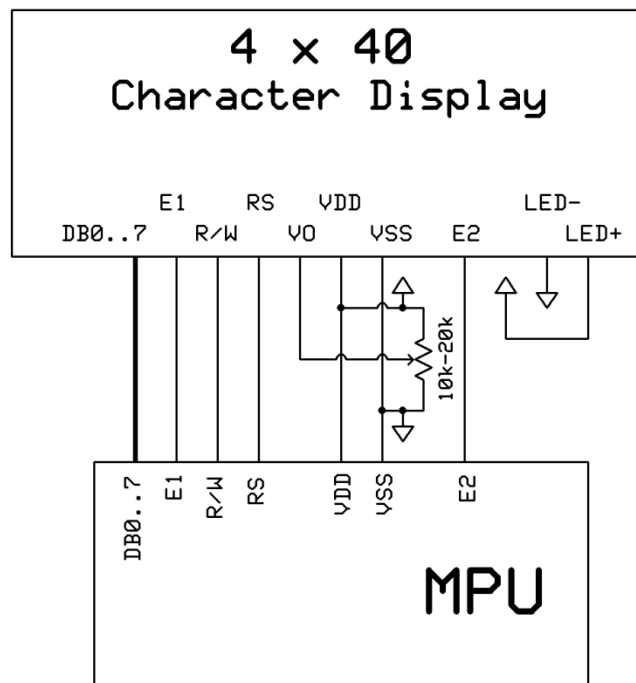

Electrical Characteristics

Item	Symbol	Condition	Min.	Typ.	Max.	Unit
Operating Temperature Range	T _{OP}	Absolute Max	-20	-	+70	°C
Storage Temperature Range	T _{ST}	Absolute Max	-30	-	+80	°C
Supply Voltage	V _{DD}	-	4.8	5.0	5.2	V
Supply Current	I _{DD}	V _{DD} = 5.0V	2	3	5	mA
Supply for LCD (contrast)	V _{LCD}	T _{OP} = 25°C	4.1	4.3	4.5	V
"H" Level input	V _{IH}	-	0.7*V _{DD}	-	V _{DD}	V
"L" Level input	V _{IL}	-	V _{SS}	-	0.6	V
"H" Level output	V _{OH}	-	3.9	-	V _{DD}	V
"L" Level output	V _{OL}	-	V _{SS}	-	0.4	V
Backlight Supply Voltage	V _{LED}	-	4.8	5.0	5.2	V
Backlight Supply Current	I _{LED}	V _{LED} = 5.0V	240	320	480	mA

Optical Characteristics

Item	Symbol	Condition	Min.	Typ.	Max.	Unit
Optimal Viewing Angles	Top	CR ≥ 2	-	40	-	°
	Bottom		-	60	-	°
	Left		-	60	-	°
	Right		-	60	-	°
Contrast Ratio	CR	-	2	5	-	-
Response Time	Rise	T _{OP} = 25°C	-	120	150	ms
	Fall		-	120	150	ms

Controller Information

Built-in ST7066U controller.

Please download specification at http://www.newhavendisplay.com/app_notes/ST7066U.pdf

DDRAM Address

1	2	3	4	5	-	-	-	-	-	-	-	-	-	-	36	37	38	39	40
00	01	02	03	04	-	-	-	-	-	-	-	-	-	-	23	24	25	26	27
40	41	42	43	44	-	-	-	-	-	-	-	-	-	-	63	64	65	66	67
00	01	02	03	04	-	-	-	-	-	-	-	-	-	-	23	24	25	26	27
40	41	42	43	44	-	-	-	-	-	-	-	-	-	-	63	64	65	66	67

Table of Commands

Instruction	Instruction code										Description	Execution time (f _{osc} =270 KHZ)	
	RS	R/W	DB7	DB6	DB5	DB4	DB3	DB2	DB1	DB0			
Clear Display	0	0	0	0	0	0	0	0	0	0	1	Write "20H" to DDRAM and set DDRAM address to "00H" from AC	1.52ms
Return Home	0	0	0	0	0	0	0	0	0	1	-	Set DDRAM Address to "00H" from AC and return cursor to its original position if shifted. The contents of DDRAM are not changed.	1.52ms
Entry mode Set	0	0	0	0	0	0	0	0	1	I/D	SH	Sets cursor move direction and specifies display shift. These parameters are performed during data write and read.	37μs
Display ON/OFF control	0	0	0	0	0	0	0	1	D	C	B	D=1: Entire display on C=1: Cursor on B=1: Blinking cursor on	37μs
Cursor or Display shift	0	0	0	0	0	0	1	S/C	R/L	-	-	Sets cursor moving and display shift control bit, and the direction without changing DDRAM data.	37μs
Function set	0	0	0	0	0	1	DL	N	F	-	-	DL: Interface data is 8/4 bits N: Number of lines is 2/1 F: Font size is 5x11/5x8	37μs
Set CGRAM Address	0	0	0	1	AC5	AC4	AC3	AC2	AC1	AC0		Set CGRAM address in address counter	37μs
Set DDRAM Address	0	0	1	AC6	AC5	AC4	AC3	AC2	AC1	AC0		Set DDRAM address in address counter.	37μs
Read busy Flag and Address	0	1	BF	AC6	AC5	AC4	AC3	AC2	AC1	AC0		Whether during internal operation or not can be known by reading BF. The contents of address counter can also be read.	0s
Write data To Address	1	0	D7	D6	D5	D4	D3	D2	D1	D0		Write data into internal RAM (DDRAM/CGRAM).	37μs
Read data From RAM	1	1	D7	D6	D5	D4	D3	D2	D1	D0		Read data from internal RAM (DDRAM/CGRAM).	37μs

Timing Characteristics

Writing data from MPU to ST7066U

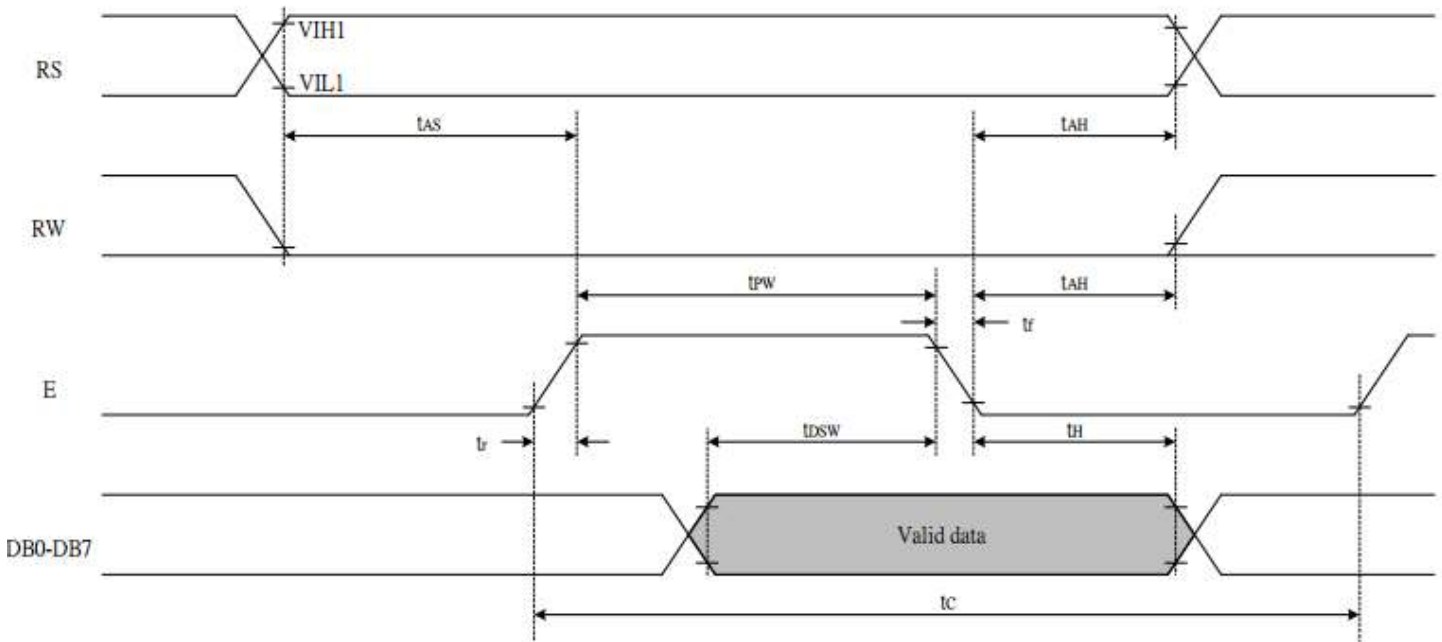

Write Mode (Writing data from MPU to ST7066U)						
T _C	Enable Cycle Time	Pin E	1200	-	-	ns
T _{PW}	Enable Pulse Width	Pin E	140	-	-	ns
T _R , T _F	Enable Rise/Fall Time	Pin E	-	-	25	ns
T _{AS}	Address Setup Time	Pins: RS,RW,E	0	-	-	ns
T _{AH}	Address Hold Time	Pins: RS,RW,E	10	-	-	ns
T _{DSW}	Data Setup Time	Pins: DB0 - DB7	40	-	-	ns
T _H	Data Hold Time	Pins: DB0 - DB7	10	-	-	ns

Reading data from ST7066U to MPU

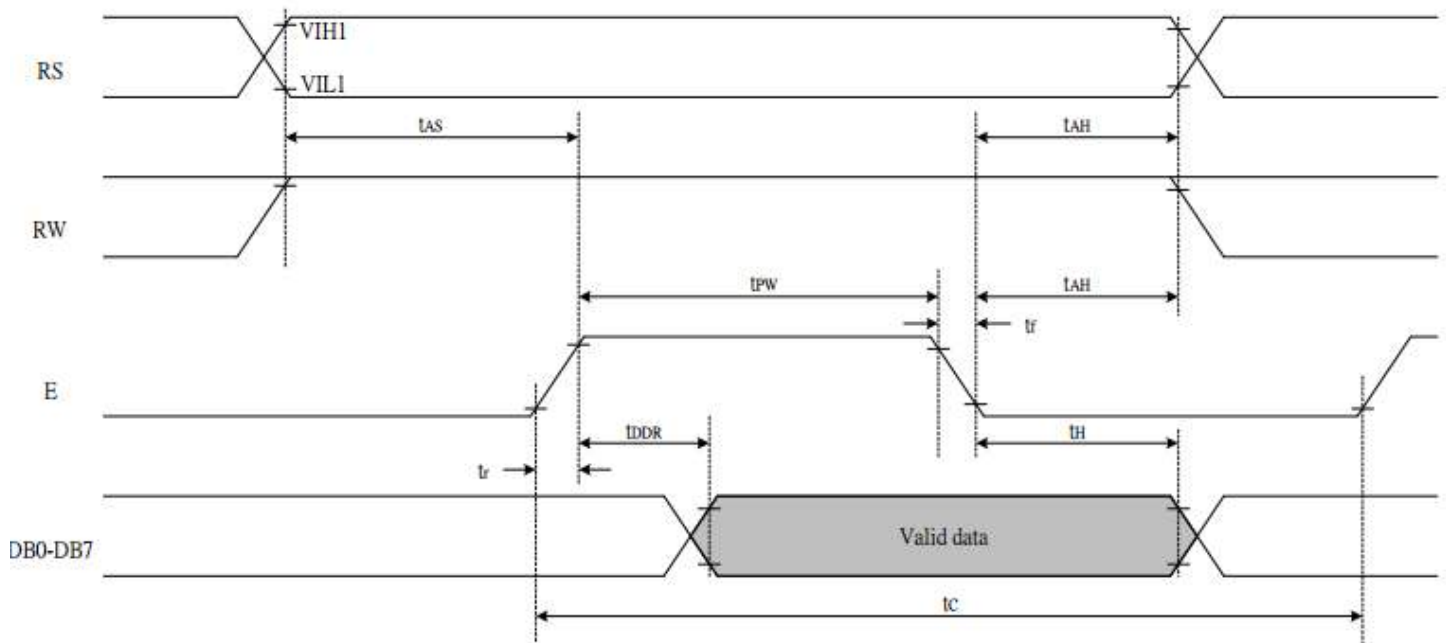

Read Mode (Reading Data from ST7066U to MPU)						
T_C	Enable Cycle Time	Pin E	1200	-	-	ns
T_{PW}	Enable Pulse Width	Pin E	140	-	-	ns
T_R, T_F	Enable Rise/Fall Time	Pin E	-	-	25	ns
T_{AS}	Address Setup Time	Pins: RS,RW,E	0	-	-	ns
T_{AH}	Address Hold Time	Pins: RS,RW,E	10	-	-	ns
T_{DDR}	Data Setup Time	Pins: DB0 - DB7	-	-	100	ns
T_H	Data Hold Time	Pins: DB0 - DB7	10	-	-	ns

Built-in Font Table

b7-b4 b3-b0	0000	0001	0010	0011	0100	0101	0110	0111	1000	1001	1010	1011	1100	1101	1110	1111
0000	CG RAM (1)			0	1	P	^	P				—	9	3	0	P
0001	(2)		!	1	A	0	a	A			a	7	7	4	3	q
0010	(3)		"	2	B	R	b	r			"	4	9	×	P	0
0011	(4)		#	3	C	S	c	s			!	9	7	e	e	*
0100	(5)		*	4	D	T	d	t			\	1	1	6	P	0
0101	(6)		%	5	E	U	e	u			.	7	6	1	0	0
0110	(7)		&	6	F	V	f	v			7	0	2	3	P	2
0111	(8)		'	7	G	W	g	w			7	7	7	7	g	n
1000	(1)		<	8	H	X	h	x			4	9	*	9	7	2
1001	(2)		>	9	I	Y	i	y			0	7	7	6	7	y
1010	(3)		*	:	J	Z	j	z			2	0	0	4	j	7
1011	(4)		+	:	K	L	k	l			*	9	0	0	*	n
1100	(5)		,	<	L	*	l	l			6	9	7	7	0	n
1101	(6)		—	=	M	J	m	j			2	2	2	2	l	÷
1110	(7)		.	>	N	^	n	^			3	0	0	^	n	
1111	(8)		/	?	0	_	o	←			0	9	7	"	0	■

Example Initialization Program

```
/******  
void command1(char i)          //Top half of the display  
{  
    P1 = i;  
    W = 0;  
    RS = 0;  
    E1 = 1;  
    delay(2);  
    E1 = 0;  
}  
void command2(char i)          //Bottom half of the display  
{  
    P1 = i;  
    W = 0;  
    RS = 0;  
    E2 = 1;  
    delay(2);  
    E2 = 0;  
}  
/******  
void writedata1(char i)        //Top half of the display  
{  
    P1 = i;  
    W = 0;  
    RS = 1;  
    E1 = 1;  
    delay(2);  
    E1 = 0;  
}  
void writedata2(char i)        //Bottom half of the display  
{  
    P1 = i;  
    W = 0;  
    RS = 1;  
    E2 = 1;  
    delay(2);  
    E2 = 0;  
}  
/******  
void init_LCD()  
{  
    delay(15);  
    command1(0x30);    //Wake up  
    command2(0x30);  
    delay(5);  
    command1(0x30);    //Wake up  
    command2(0x30);  
    delay(5);  
    command1(0x30);    //Wake up  
    command2(0x30);  
    delay(5);  
    command1(0x38);    //Function Set = 8bit mode; 2-line; 5x8  
    command2(0x38);  
    command1(0x08);    //Turn off display  
    command2(0x08);  
    command1(0x01);    //Clear display  
    command2(0x01);  
    command1(0x06);    //Entry mode cursor increment  
    command2(0x06);  
    command1(0x0c);    //Turn on display; no cursor  
    command2(0x0c);  
}  
/******
```

Quality Information

Test Item	Content of Test	Test Condition	Note
High Temperature storage	Endurance test applying the high storage temperature for a long time.	+80°C , 48hrs	2
Low Temperature storage	Endurance test applying the low storage temperature for a long time.	-30°C , 48hrs	1,2
High Temperature Operation	Endurance test applying the electric stress (voltage & current) and the high thermal stress for a long time.	+70°C 48hrs	2
Low Temperature Operation	Endurance test applying the electric stress (voltage & current) and the low thermal stress for a long time.	-20°C , 48hrs	1,2
High Temperature / Humidity Operation	Endurance test applying the electric stress (voltage & current) and the high thermal with high humidity stress for a long time.	+40°C , 90% RH , 48hrs	1,2
Thermal Shock resistance	Endurance test applying the electric stress (voltage & current) during a cycle of low and high thermal stress.	0°C,30min -> 25°C,5min -> 50°C,30min = 1 cycle 10 cycles	
Vibration test	Endurance test applying vibration to simulate transportation and use.	10-55Hz , 15mm amplitude. 60 sec in each of 3 directions X,Y,Z For 15 minutes	3
Static electricity test	Endurance test applying electric static discharge.	VS=800V, RS=1.5kΩ, CS=100pF One time	

Note 1: No condensation to be observed.

Note 2: Conducted after 4 hours of storage at 25°C, 0%RH.

Note 3: Test performed on product itself, not inside a container.

Precautions for using LCDs/LCMs

See Precautions at www.newhavendisplay.com/specs/precautions.pdf

Warranty Information and Terms & Conditions

http://www.newhavendisplay.com/index.php?main_page=terms