



# FOD2711

## Optically Isolated Error Amplifier

### Features

- Optocoupler, precision reference and error amplifier in single package
- 1.240V  $\pm$  1% reference
- CTR 100% to 200%
- 5,000V RMS isolation
- UL approval E90700, Volume 2  
CSA approval 1296837  
VDE approval 40002463  
BSI approval 8702, 8703

### Applications

- Power supplies regulation
- DC to DC converters

### Description

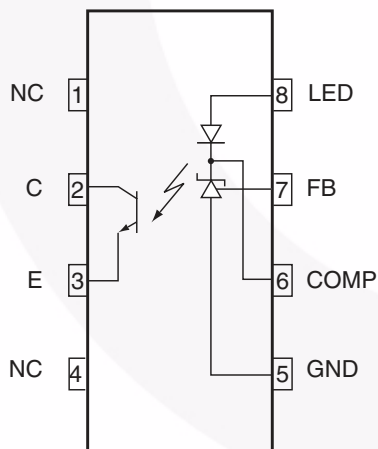
The FOD2711 Optically Isolated Amplifier consists of the popular RC431A precision programmable shunt reference and an optocoupler. The optocoupler is a gallium arsenide (GaAs) light emitting diode optically coupled to a silicon phototransistor. The reference voltage tolerance is 1%. The current transfer ratio (CTR) ranges from 100% to 200%.

It is primarily intended for use as the error amplifier/reference voltage/optocoupler function in isolated AC to DC power supplies and dc/dc converters.

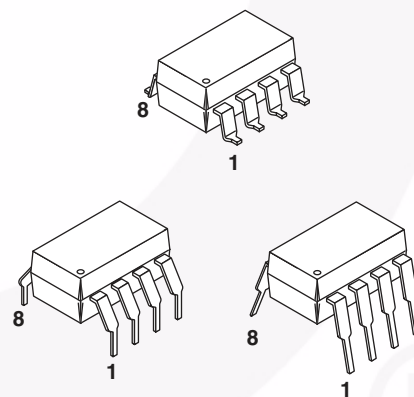
When using the FOD2711, power supply designers can reduce the component count and save space in tightly packaged designs. The tight tolerance reference eliminates the need for adjustments in many applications.

The device comes in a 8-pin dip white package.

### Functional Block Diagram



### Package Outlines





**Absolute Maximum Ratings** ( $T_A = 25^\circ\text{C}$  unless otherwise specified)

Stresses exceeding the absolute maximum ratings may damage the device. The device may not function or be operable above the recommended operating conditions and stressing the parts to these levels is not recommended. In addition, extended exposure to stresses above the recommended operating conditions may affect device reliability. The absolute maximum ratings are stress ratings only.

Symbol	Parameter	Value	Units
$T_{\text{STG}}$	Storage Temperature	-40 to +125	$^\circ\text{C}$
$T_{\text{OPR}}$	Operating Temperature	-40 to +85	$^\circ\text{C}$
$T_{\text{SOL}}$	Lead Solder Temperature	260 for 10 sec.	$^\circ\text{C}$
$V_{\text{LED}}$	Input Voltage	13.2	V
$I_{\text{LED}}$	Input DC Current	20	mA
$V_{\text{CEO}}$	Collector-Emitter Voltage	30	V
$V_{\text{ECO}}$	Emitter-Collector Voltage	7	V
$I_{\text{C}}$	Collector Current	50	mA
PD1	Input Power Dissipation <sup>(1)</sup>	145	mW
PD2	Transistor Power Dissipation <sup>(2)</sup>	85	mW
PD3	Total Power Dissipation <sup>(3)</sup>	145	mW

**Notes:**

1. Derate linearly from  $25^\circ\text{C}$  at a rate of  $2.42\text{mW}/^\circ\text{C}$
2. Derate linearly from  $25^\circ\text{C}$  at a rate of  $1.42\text{mW}/^\circ\text{C}$ .
3. Derate linearly from  $25^\circ\text{C}$  at a rate of  $2.42\text{mW}/^\circ\text{C}$ .

**Electrical Characteristics** ( $T_A = 25^\circ\text{C}$  unless otherwise specified)**Input Characteristics**

Symbol	Parameter	Test Conditions	Min.	Typ.*	Max.	Unit
$V_F$	LED Forward Voltage	$I_{LED} = 10\text{mA}$ , $V_{COMP} = V_{FB}$ (Fig. 1)			1.5	V
$V_{REF}$	Reference Voltage -40°C to +85°C 25°C	$V_{COMP} = V_{FB}$ , $I_{LED} = 10\text{mA}$ (Fig.1)	1.221		1.259	V
			1.228	1.240	1.252	
$V_{REF(DEV)}$	Deviation of $V_{REF}$ Over Temperature <sup>(4)</sup>	$T_A = -40$ to $+85^\circ\text{C}$		4	12	mV
$\frac{\Delta V_{REF}}{\Delta V_{COMP}}$	Ratio of Vref Variation to the Output of the Error Amplifier	$I_{LED} = 10\text{mA}$ , $V_{COMP} = V_{REF}$ to 12V (Fig. 2)		-1.5	-2.7	mV/V
$I_{REF}$	Feedback Input Current	$I_{LED} = 10\text{mA}$ , $R1 = 10\text{k}\Omega$ (Fig. 3)		0.15	0.5	$\mu\text{A}$
$I_{REF(DEV)}$	Deviation of $I_{REF}$ Over Temperature <sup>(4)</sup>	$T_A = -40^\circ\text{C}$ to $+85^\circ\text{C}$		0.15	0.3	$\mu\text{A}$
$I_{LED(MIN)}$	Minimum Drive Current	$V_{COMP} = V_{FB}$ (Fig. 1)		55	80	$\mu\text{A}$
$I_{(OFF)}$	Off-State Error Amplifier Current	$V_{LED} = 6\text{V}$ , $V_{FB} = 0$ (Fig. 4)		0.001	0.1	$\mu\text{A}$
$ Z_{OUT} $	Error Amplifier Output Impedance <sup>(5)</sup>	$V_{COMP} = V_{FB}$ , $I_{LED} = 0.1\text{mA}$ to $15\text{mA}$ , $f < 1\text{KHZ}$		0.25		$\Omega$

**Output Characteristics**

Symbol	Parameter	Test Conditions	Min.	Typ.	Max.	Unit
$I_{CEO}$	Collector Dark Current	$V_{CE} = 10\text{V}$ (Fig. 5)			50	nA
$BV_{ECO}$	Emitter-Collector Voltage Breakdown	$I_E = 100\mu\text{A}$	7			V
$BV_{CEO}$	Collector-Emitter Voltage Breakdown	$I_C = 1.0\text{mA}$	70			V

**Transfer Characteristics**

Symbol	Parameter	Test Conditions	Min.	Typ.	Max.	Unit
CTR	Current Transfer Ratio	$I_{LED} = 10\text{mA}$ , $V_{COMP} = V_{FB}$ , $V_{CE} = 5\text{V}$ (Fig. 6)	100		200	%
$V_{CE(SAT)}$	Collector-Emitter Saturation Voltage	$I_{LED} = 10\text{mA}$ , $V_{COMP} = V_{FB}$ , $I_C = 2.5\text{mA}$ (Fig. 6)			0.4	V

**Notes:**

4. The deviation parameters  $V_{REF(DEV)}$  and  $I_{REF(DEV)}$  are defined as the differences between the maximum and minimum values obtained over the rated temperature range. The average full-range temperature coefficient of the reference input voltage,  $\Delta V_{REF}$ , is defined as:

$$|\Delta V_{REF}|(\text{ppm}/^\circ\text{C}) = \frac{\{V_{REF(DEV)}/V_{REF}(T_A = 25^\circ\text{C})\} \times 10^6}{\Delta T_A}$$

where  $\Delta T_A$  is the rated operating free-air temperature range of the device.

5. The dynamic impedance is defined as  $|Z_{OUT}| = \Delta V_{COMP} / \Delta I_{LED}$ . When the device is operating with two external resistors (see Figure 2), the total dynamic impedance of the circuit is given by:

$$|Z_{OUT, TOT}| = \frac{\Delta V}{\Delta I} \approx |Z_{OUT}| \times \left[ 1 + \frac{R1}{R2} \right]$$

**Electrical Characteristics** (Continued) ( $T_A = 25^\circ\text{C}$  unless otherwise specified)**Isolation Characteristics**

Symbol	Parameter	Test Conditions	Min.	Typ.	Max.	Unit
$I_{I-O}$	Input-Output Insulation Leakage Current	RH = 45%, $T_A = 25^\circ\text{C}$ , $t = 5\text{s}$ , $V_{I-O} = 3000\text{ VDC}^{(6)}$			1.0	$\mu\text{A}$
$V_{ISO}$	Withstand Insulation Voltage	RH $\leq$ 50%, $T_A = 25^\circ\text{C}$ , $t = 1\text{ min.}^{(6)}$	5000			Vrms
$R_{I-O}$	Resistance (Input to Output)	$V_{I-O} = 500\text{ VDC}^{(6)}$		$10^{12}$		$\Omega$

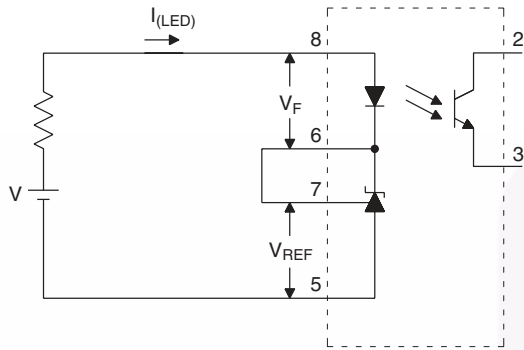
**Switching Characteristics**

Symbol	Parameter	Test Conditions	Min.	Typ.	Max.	Unit
BW	Bandwidth	(Fig. 7)		10		kHZ
CMH	Common Mode Transient Immunity at Output HIGH	$I_{LED} = 0\text{mA}$ , $ V_{cm}  = 10\text{ V}_{PP}$ , $R_L = 2.2\text{k}\Omega^{(7)}$ (Fig. 8)		1.0		$\text{kV}/\mu\text{s}$
CML	Common Mode Transient Immunity at Output LOW	$I_{LED} = 1\text{mA}$ , $ V_{cm}  = 10\text{ V}_{PP}$ , $R_L = 2.2\text{k}\Omega^{(7)}$ (Fig. 8)		1.0		$\text{kV}/\mu\text{s}$

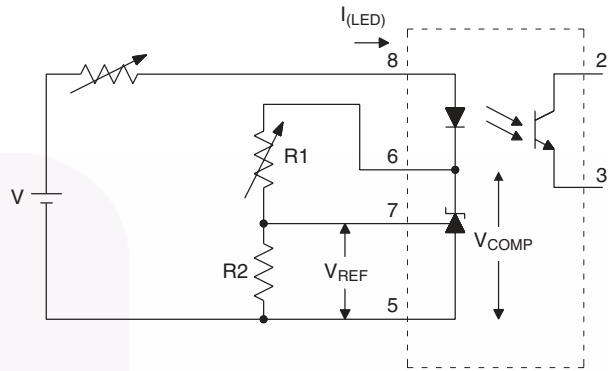
**Notes:**

- Device is considered as a two terminal device: Pins 1, 2, 3 and 4 are shorted together and Pins 5, 6, 7 and 8 are shorted together.
- Common mode transient immunity at output high is the maximum tolerable (positive)  $dV_{cm}/dt$  on the leading edge of the common mode impulse signal,  $V_{cm}$ , to assure that the output will remain high. Common mode transient immunity at output low is the maximum tolerable (negative)  $dV_{cm}/dt$  on the trailing edge of the common pulse signal,  $V_{cm}$ , to assure that the output will remain low.

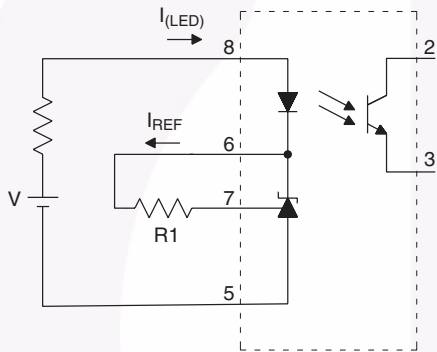
### Test Circuits



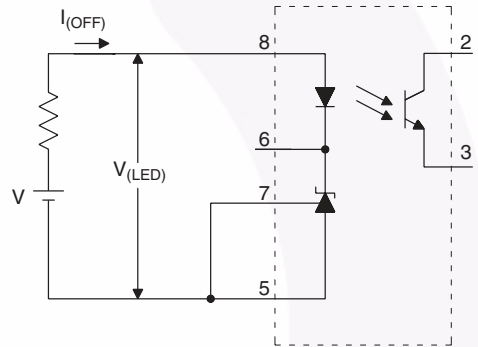
**Figure 1.  $V_{REF}$ ,  $V_F$ ,  $I_{LED}$  (min.) Test Circuit**



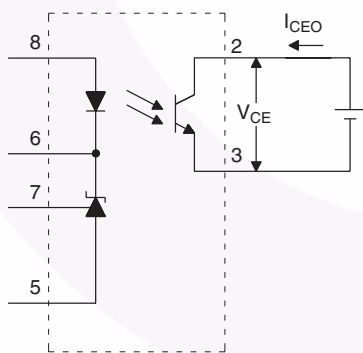
**Figure 2.  $\Delta V_{REF} / \Delta V_{COMP}$  Test Circuit**



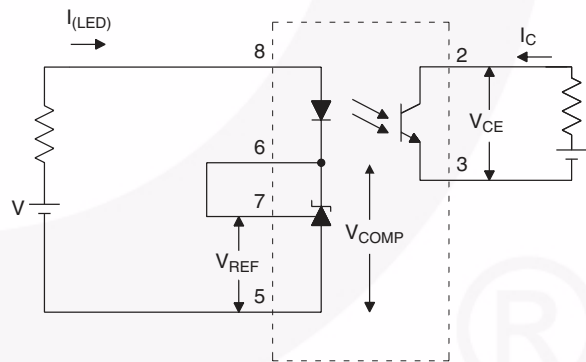
**Figure 3.  $I_{REF}$  Test Circuit**



**Figure 4.  $I_{(OFF)}$  Test Circuit**



**Figure 5.  $I_{CEO}$  Test Circuit**



**Figure 6.  $CTR$ ,  $V_{CE(sat)}$  Test Circuit**

Test Circuits (Continued)

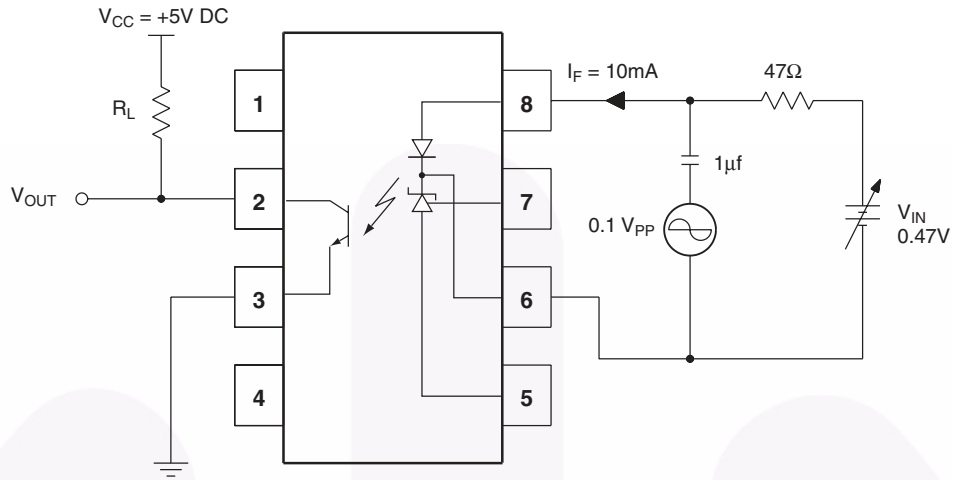


Figure 7. Frequency Response Test Circuit

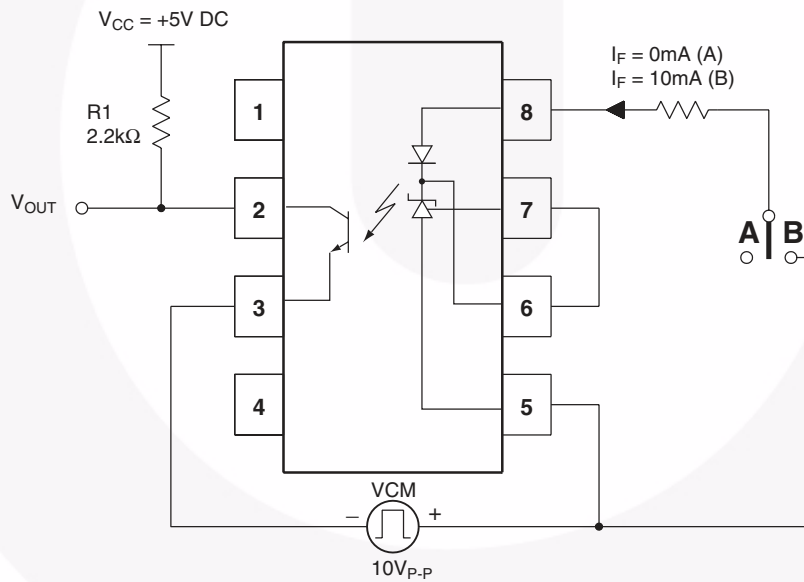
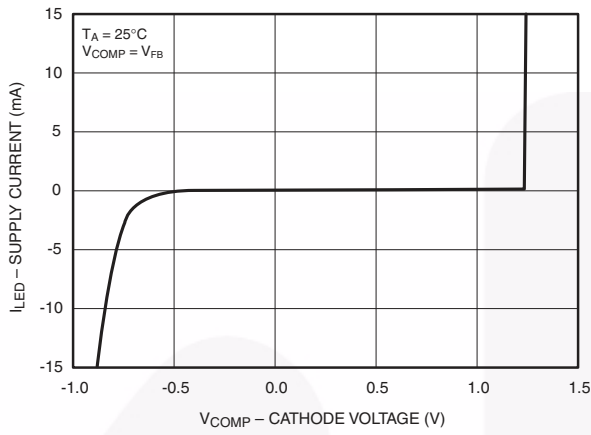


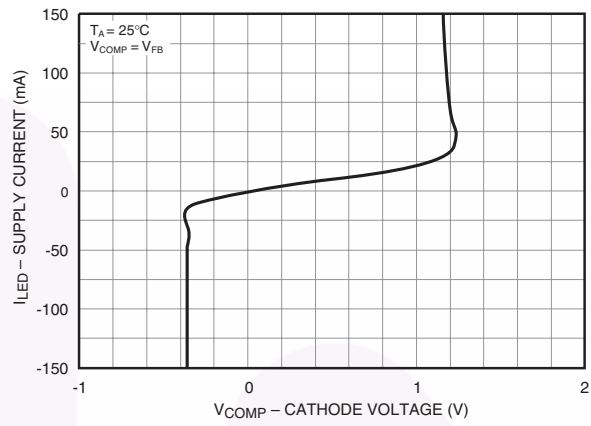
Figure 8. CMH and CML Test Circuit

## Typical Performance Curves

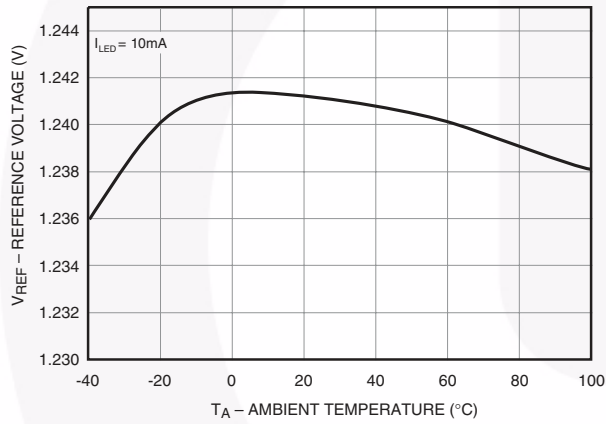
**Fig. 9a LED Current vs. Cathode Voltage**



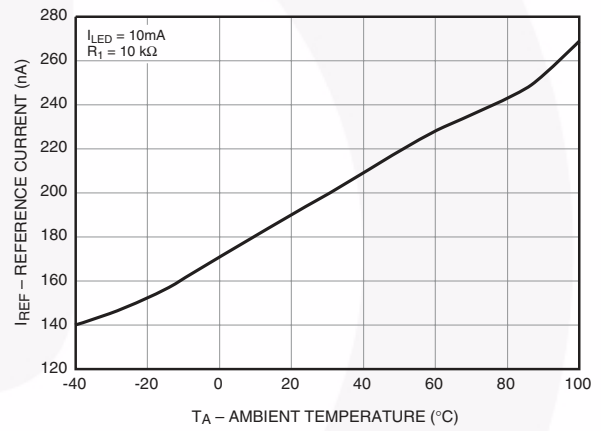
**Fig. 9b LED Current vs. Cathode Voltage**



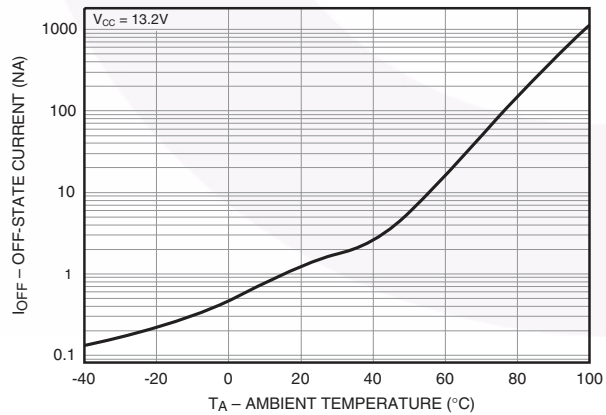
**Fig. 10 Reference Voltage vs. Ambient Temperature**



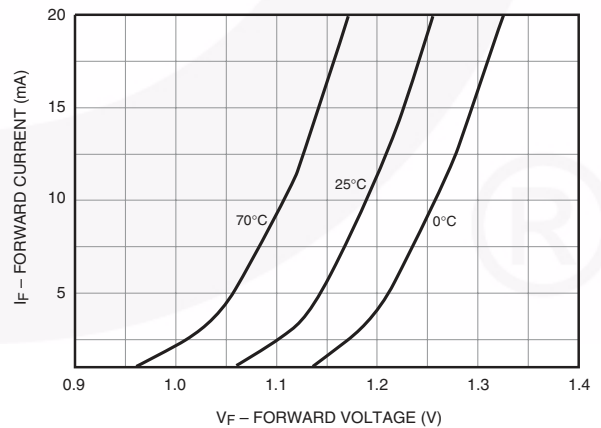
**Fig. 11 Reference Current vs. Ambient Temperature**



**Fig. 12 Off-State Current vs. Ambient Temperature**



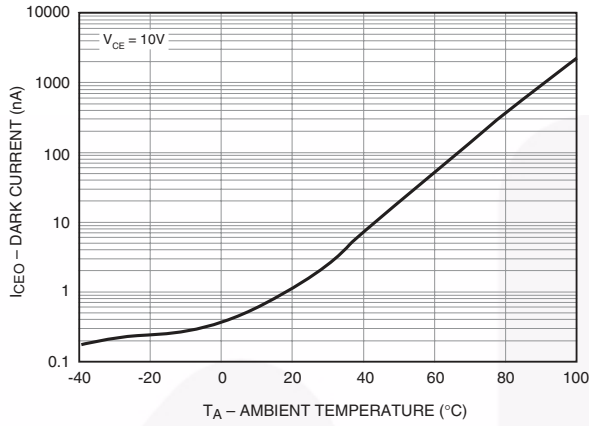
**Fig. 13 Forward Current vs. Forward Voltage**



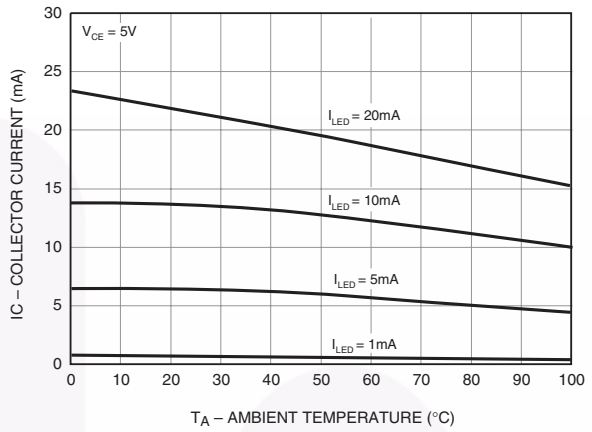


## Typical Performance Curves (Continued)

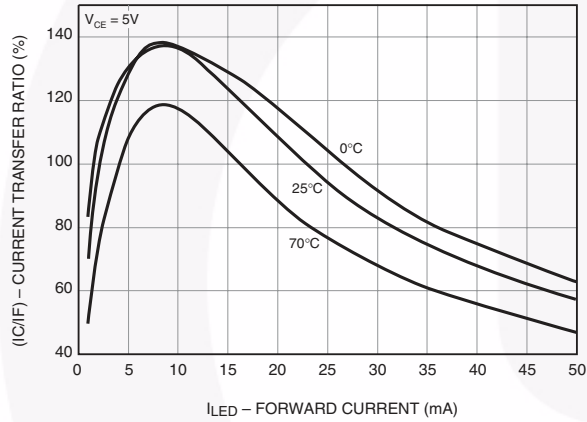
**Fig. 14 Dark Current vs. Ambient Temperature**



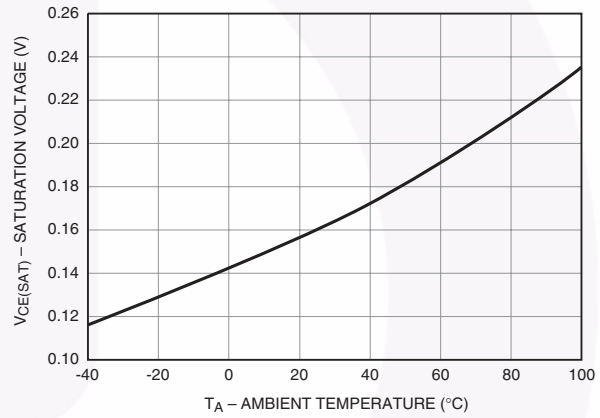
**Fig. 15 Collector Current vs. Ambient Temperature**



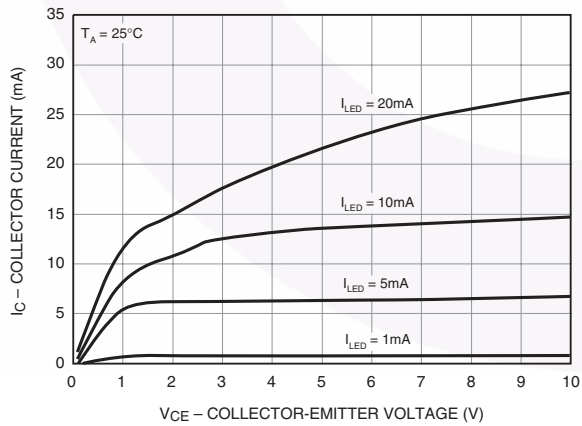
**Fig. 16 Current Transfer Ratio vs. LED Current**



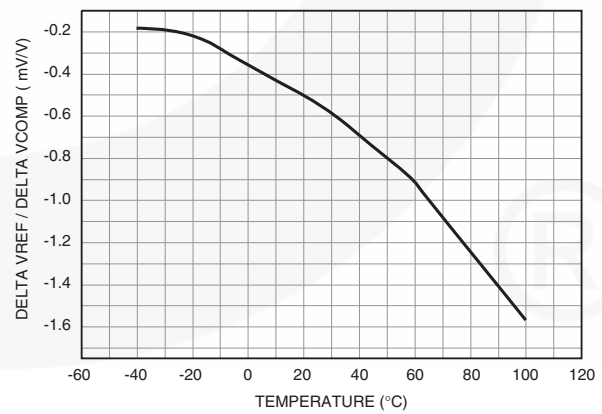
**Fig. 17 Saturation Voltage vs. Ambient Temperature**



**Fig. 18 Collector Current vs. Collector Voltage**

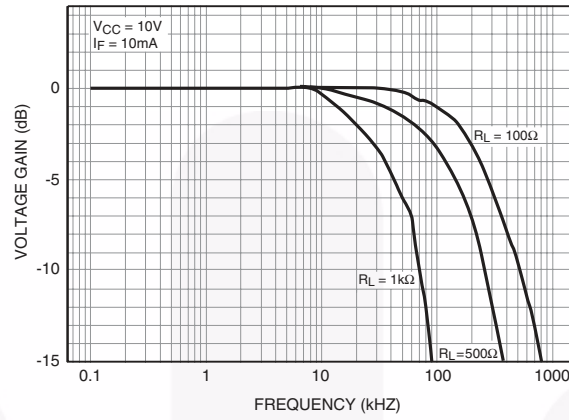


**Fig. 19 Rate of Change  $V_{REF}$  to  $V_{COMP}$  vs. Temperature**



Typical Performance Curves (Continued)

Fig. 20 Voltage Gain vs. Frequency



## The FOD2711

The FOD2711 is an optically isolated error amplifier. It incorporates three of the most common elements necessary to make an isolated power supply, a reference voltage, an error amplifier, and an optocoupler. It is functionally equivalent to the popular RC431A shunt voltage regulator plus the CNY17F-3 optocoupler.

### Powering the Secondary Side

The LED pin in the FOD2711 powers the secondary side, and in particular provides the current to run the LED. The actual structure of the FOD2711 dictates the minimum voltage that can be applied to the LED pin: The error amplifier output has a minimum of the reference voltage, and the LED is in series with that. Minimum voltage applied to the LED pin is thus  $1.24V + 1.5V = 2.74V$ . This voltage can be generated either directly from the output of the converter, or else from a slaved secondary winding. The secondary winding will not affect regulation, as the input to the FB pin may still be taken from the output winding.

The LED pin needs to be fed through a current limiting resistor. The value of the resistor sets the amount of current through the LED, and thus must be carefully selected in conjunction with the selection of the primary side resistor.

### Feedback

Output voltage of a converter is determined by selecting a resistor divider from the regulated output to the FB pin. The FOD2711 attempts to regulate its FB pin to the reference voltage, 1.24V. The ratio of the two resistors should thus be:

$$\frac{R_{TOP}}{R_{BOTTOM}} = \frac{V_{OUT}}{V_{REF}} - 1$$

The absolute value of the top resistor is set by the input offset current of  $0.8\mu A$ . To achieve 1% accuracy, the resistance of  $R_{TOP}$  should be:

$$\frac{V_{OUT} - 1.24}{R_{TOP}} > 80\mu A$$

### Compensation

The compensation pin of the FOD2711 provides the opportunity for the designer to design the frequency response of the converter. A compensation network may be placed between the COMP pin and the FB pin. In typical low-bandwidth systems, a  $0.1\mu F$  capacitor may be used. For converters with more stringent requirements, a network should be designed based on measurements of the system's loop. An excellent reference for this process may be found in "Practical Design of Power Supplies" by Ron Lenk, IEEE Press, 1998.

### Secondary Ground

The GND pin should be connected to the secondary ground of the converter.

### No Connect Pins

The NC pins have no internal connection. They should not have any connection to the secondary side, as this may compromise the isolation structure.

### Photo-Transistor

The Photo-transistor is the output of the FOD2711. In a normal configuration the collector will be attached to a pull-up resistor and the emitter grounded. There is no base connection necessary.

The value of the pull-up resistor, and the current limiting resistor feeding the LED, must be carefully selected to account for voltage range accepted by the PWM IC, and for the variation in current transfer ratio (CTR) of the opto-isolator itself.

**Example:** The voltage feeding the LED pins is +12V, the voltage feeding the collector pull-up is +10V, and the PWM IC is the Fairchild KA1H0680, which has a 5V reference. If we select a  $10K\Omega$  resistor for the LED, the maximum current the LED can see is:

$$(12V - 2.74V) / 10k\Omega = 926\mu A$$

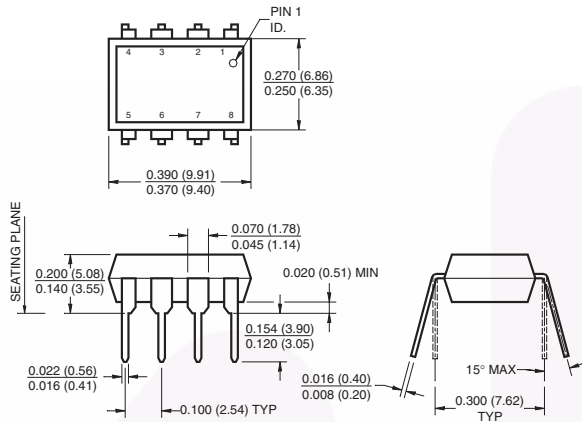
The CTR of the opto-isolator is a minimum of 100%, and so the minimum collector current of the photo-transistor when the diode is full on is also  $926\mu A$ . The collector resistor must thus be such that:

$$\frac{10V - 5V}{R_{COLLECTOR}} < 926\mu A \text{ or } R_{COLLECTOR} > 5.4K\Omega;$$

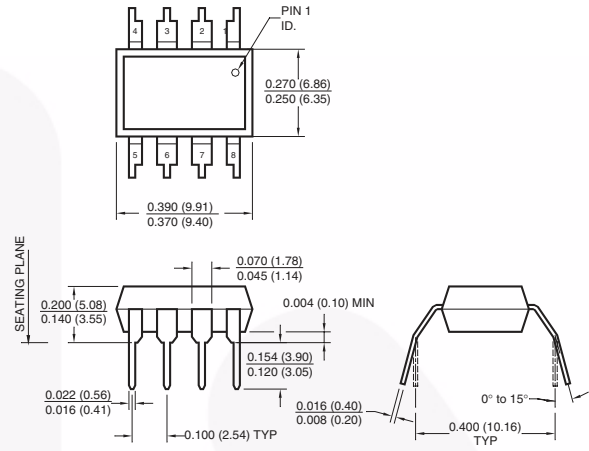
select  $10k\Omega$  to allow some margin.

## Package Dimensions

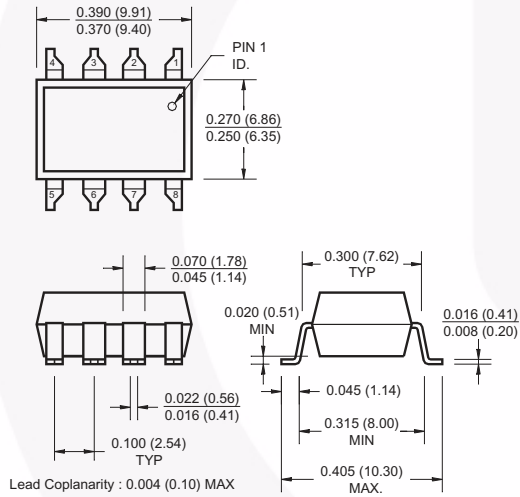
### Through Hole



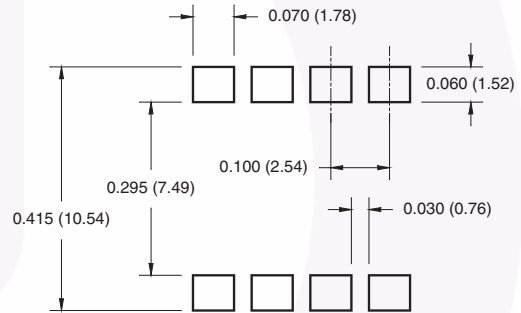
### 0.4" Lead Spacing



### Surface Mount



### 8-Pin DIP – Land Pattern



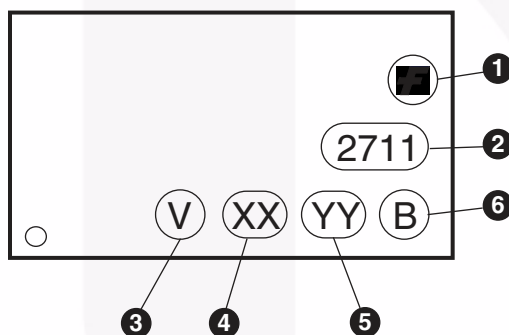
**Note:**

All dimensions are in inches (millimeters)

## Ordering Information

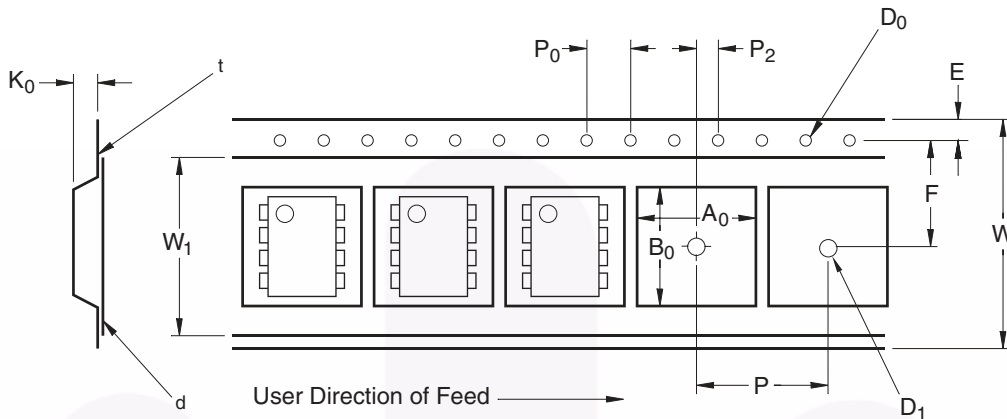
Option	Example Part Number	Description
No Option	FOD2711A	Standard Through Hole
S	FOD2711AS	Surface Mount Lead Bend
SD	FOD2711ASD	Surface Mount; Tape and Reel
T	FOD2711AT	0.4" Lead Spacing
V	FOD2711AV	VDE0884
TV	FOD2711ATV	VDE0884; 0.4" Lead Spacing
SV	FOD2711ASV	VDE0884; Surface Mount
SDV	FOD2711ASDV	VDE0884; Surface Mount; Tape and Reel

## Marking Information



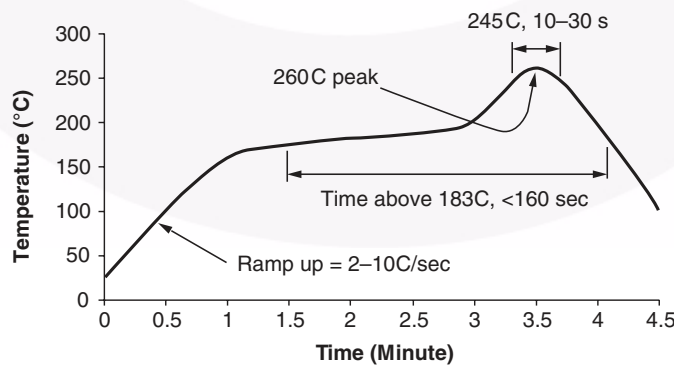
Definitions	
1	Fairchild logo
2	Device number
3	VDE mark (Note: Only appears on parts ordered with VDE option – See order entry table)
4	Two digit year code, e.g., '03'
5	Two digit work week ranging from '01' to '53'
6	Assembly package code

## Carrier Tape Specifications



Symbol	Description	Dimension in mm
W	Tape Width	16.0 ± 0.3
t	Tape Thickness	0.30 ± 0.05
P <sub>0</sub>	Sprocket Hole Pitch	4.0 ± 0.1
D <sub>0</sub>	Sprocket Hole Diameter	1.55 ± 0.05
E	Sprocket Hole Location	1.75 ± 0.10
F	Pocket Location	7.5 ± 0.1
P <sub>2</sub>		4.0 ± 0.1
P	Pocket Pitch	12.0 ± 0.1
A <sub>0</sub>	Pocket Dimensions	10.30 ± 0.20
B <sub>0</sub>		10.30 ± 0.20
K <sub>0</sub>		4.90 ± 0.20
W <sub>1</sub>	Cover Tape Width	1.6 ± 0.1
d	Cover Tape Thickness	0.1 max
	Max. Component Rotation or Tilt	10°
R	Min. Bending Radius	30

## Reflow Profile



- Peak reflow temperature: 260C (package surface temperature)
- Time of temperature higher than 183C for 160 seconds or less
- One time soldering reflow is recommended



Build it Now™	FPS™	PDP SPM™	The Power Franchise®
CorePLUS™	F-PFS™	Power-SPM™	the power™
CorePOWER™	FRFET®	PowerTrench®	franchise
CROSSVOLT™	Global Power Resource <sup>SM</sup>	Programmable Active Droop™	TinyBoost™
CTL™	Green FPS™	QFET®	TinyBuck™
Current Transfer Logic™	Green FPS™ e-Series™	QS™	TinyLogic®
EcoSPARK®	GTO™	Quiet Series™	TINYOPTO™
EfficientMax™	IntelliMAX™	RapidConfigure™	TinyPower™
EZSWITCH™ *	ISOPLANAR™	Saving our world, 1mW at a time™	TinyPWM™
	MegaBuck™	SmartMax™	TinyWire™
	MICROCOUPLER™	SMART START™	SerDes™
Fairchild®	MicroFET™	SPM®	
Fairchild Semiconductor®	MicroPak™	STEALTH™	UHC®
FACT Quiet Series™	MillerDrive™	SuperFET™	Ultra FRFET™
FACT®	MotionMax™	SuperSOT™3	UniFET™
FAST®	Motion-SPM™	SuperSOT™6	VCX™
FastvCore™	OPTOLOGIC®	SuperSOT™8	VisualMax™
FlashWriter® *	OPTOPLANAR®	SupreMOS™	
		SyncFET™	

\* EZSWITCH™ and FlashWriter® are trademarks of System General Corporation, used under license by Fairchild Semiconductor.

**DISCLAIMER**

FAIRCHILD SEMICONDUCTOR RESERVES THE RIGHT TO MAKE CHANGES WITHOUT FURTHER NOTICE TO ANY PRODUCTS HEREIN TO IMPROVE RELIABILITY, FUNCTION, OR DESIGN. FAIRCHILD DOES NOT ASSUME ANY LIABILITY ARISING OUT OF THE APPLICATION OR USE OF ANY PRODUCT OR CIRCUIT DESCRIBED HEREIN; NEITHER DOES IT CONVEY ANY LICENSE UNDER ITS PATENT RIGHTS, NOR THE RIGHTS OF OTHERS. THESE SPECIFICATIONS DO NOT EXPAND THE TERMS OF FAIRCHILD'S WORLDWIDE TERMS AND CONDITIONS, SPECIFICALLY THE WARRANTY THEREIN, WHICH COVERS THESE PRODUCTS.

**LIFE SUPPORT POLICY**

FAIRCHILD'S PRODUCTS ARE NOT AUTHORIZED FOR USE AS CRITICAL COMPONENTS IN LIFE SUPPORT DEVICES OR SYSTEMS WITHOUT THE EXPRESS WRITTEN APPROVAL OF FAIRCHILD SEMICONDUCTOR CORPORATION.

As used herein:

1. Life support devices or systems are devices or systems which, (a) are intended for surgical implant into the body or (b) support or sustain life, and (c) whose failure to perform when properly used in accordance with instructions for use provided in the labeling, can be reasonably expected to result in a significant injury of the user.
2. A critical component in any component of a life support, device, or system whose failure to perform can be reasonably expected to cause the failure of the life support device or system, or to affect its safety or effectiveness.

**ANTI-COUNTERFEITING POLICY**

Fairchild Semiconductor Corporation's Anti-Counterfeiting Policy. Fairchild's Anti-Counterfeiting Policy is also stated on our external website, [www.fairchildsemi.com](http://www.fairchildsemi.com), under Sales Support.

Counterfeiting of semiconductor parts is a growing problem in the industry. All manufacturers of semiconductor products are experiencing counterfeiting of their parts. Customers who inadvertently purchase counterfeit parts experience many problems such as loss of brand reputation, substandard performance, failed applications, and increased cost of production and manufacturing delays. Fairchild is taking strong measures to protect ourselves and our customers from the proliferation of counterfeit parts. Fairchild strongly encourages customers to purchase Fairchild parts either directly from Fairchild or from Authorized Fairchild Distributors who are listed by country on our web page cited above. Products customers buy either from Fairchild directly or from Authorized Fairchild Distributors are genuine parts, have full traceability, meet Fairchild's quality standards for handling and storage and provide access to Fairchild's full range of up-to-date technical and product information. Fairchild and our Authorized Distributors will stand behind all warranties and will appropriately address any warranty issues that may arise. Fairchild will not provide any warranty coverage or other assistance for parts bought from Unauthorized Sources. Fairchild is committed to combat this global problem and encourage our customers to do their part in stopping this practice by buying direct or from authorized distributors.

**PRODUCT STATUS DEFINITIONS**

**Definition of Terms**

Datasheet Identification	Product Status	Definition
--------------------------	----------------	------------