

General Descriptions

The NR885K series is synchronous buck regulator ICs integrates High-side and Low-side power MOSFETs. With the current mode control, ultra low ESR capacitors such as ceramic capacitors can be used. The ICs have protection functions such as Over-Current Protection (OCP), Under-Voltage Lockout (UVLO) and Thermal Shutdown (TSD). An adjustable Soft-Start by an external capacitor prevents the excessive inrush current at turn-on the regulator. The ICs integrate phase compensation circuit which reduces the number of external components and simplifies the design of customer application. The ON/OFF pin (EN Pin) turns the regulator on or off and helps to achieve low power consumption requirements. The NR885K series is available in an 8-pin HSOP8 package with an exposed thermal pad on the back side.

Package

- HSOP8
Thermally enhanced 8-Pin package

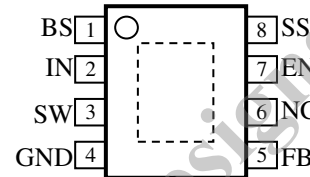
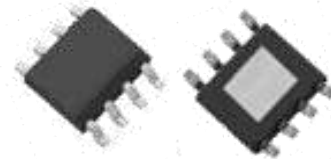

Features & Benefits

- Current mode PWM control
- Up to 95% efficiency
- Stable with low ESR ceramic output capacitors
- Built-in protection function
 - Over Current Protection (OCP)
 - Thermal Shutdown (TSD)
 - Under Voltage Lockout (UVLO)
- Built-in phase compensation
- Adjustable Soft-Start with an external capacitor
- Turn ON/OFF the regulator function

Electrical Characteristics

- 3A output current
- Operating input range $V_{IN} = 4.5V \sim 18V$
- Output adjustable $V_O = 0.8V \sim 14V$
- Fixed 350kHz frequency

Applications

- LCD TV / Blu-Ray / Set top box
- Green Electronic products
- Other power supply

Typical Application Circuit

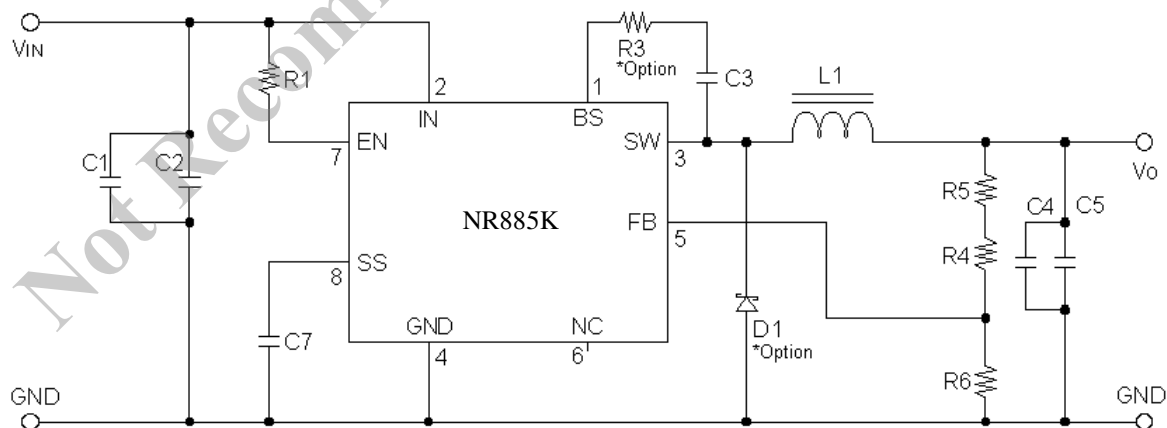

C1/C2: 10uF / 25V × 2
 C3: 0.1uF
 L1: 10uH
 R3: 22Ω (Option)
 R5: 4.3kΩ

C4/C5: 22uF / 6.3V × 2
 C7: 0.1uF
 R1: 100kΩ
 R4: 8.2 kΩ
 R6: 3.9kΩ (Vo=3.3V) D1:*Option

Absolute Maximum Ratings

Parameter	Symbol	Ratings	Units	Condition
DC input voltage	V_{IN}	20	V	
Power dissipation ⁽¹⁾	P_D	1.69	W	Glass-epoxy board mounting in a 30×30mm. (copper area in a 25×25mm) Max $T_J = 150^{\circ}\text{C}$
Junction temperature ⁽²⁾	T_J	-40 to 150	$^{\circ}\text{C}$	
Storage temperature	T_S	-40 to 150	$^{\circ}\text{C}$	
Thermal resistance (junction- Pin No. 4)	θ_{JP}	40	$^{\circ}\text{C}/\text{W}$	
Thermal resistance (junction-ambient air)	θ_{JA}	74	$^{\circ}\text{C}/\text{W}$	Glass-epoxy board mounting in a 30×30mm. (copper area in a 25×25mm)

⁽¹⁾ Limited by thermal shutdown.

⁽²⁾ The temperature detection of thermal shutdown is about 160°C

Recommended Operating Conditions ⁽³⁾

Parameter	Symbol	Ratings		Units	Condition
		MIN	MAX		
DC input voltage ⁽⁴⁾	V_{IN}	V_o+3	18	V	
DC output current ⁽⁵⁾	I_o	0	3.0	A	
Output voltage	V_o	0.8	14	V	
Ambient operating temperature ⁽⁶⁾	T_{op}	-40	85	$^{\circ}\text{C}$	

⁽³⁾ Recommended operating range indicates conditions which are required for maintaining normal circuit functions shown in Electrical Characteristics.

⁽⁴⁾ The minimum value of input voltage is taken as the larger one of either 8v or " $V_{out}+3v$ ".

In the case of $V_{IN}=V_o+1 \sim V_o+3V$, it is set to $I_{OUT}=2A$ MAX.

⁽⁵⁾ Recommended circuit refers to Typical Application Circuit.

⁽⁶⁾ To be used within the allowable package power dissipation characteristics.

Electrical Characteristics

(7)

Ta = 25°C

Parameter	Symbol	Ratings			Units	Test conditions	
		MIN	TYP	MAX			
Reference voltage	V _{REF}	0.784	0.800	0.816	V	V _{IN} = 12V, I _O = 1.0A	
Output voltage temperature coefficient	ΔV _{REF} /ΔT	—	±0.05	—	mV/°C	V _{IN} = 12V, I _O = 1.0A -40°C to +85°C	
Switching frequency	f _{SW}	280	350	420	kHz	V _{IN} = 12V, V _O = 3.3V, I _O = 1A	
Line regulation	(8) V _{Line}	—	50	—	mV	V _{IN} = 6.3V ~ 18V, V _O = 3.3V, I _O = 1A	
Load regulation	(8) V _{Load}	—	50	—	mV	V _{IN} = 12V, V _O = 3.3V, I _O = 0.1A ~ 3.0A	
Over current protection starting current	I _S	3.1	—	6.0	A	V _{IN} = 12V, V _O = 3.3V	
Supply Current	I _{IN}	—	6	—	mA	V _{IN} = 12V V _{EN} = 10kΩ pull up to V _{IN}	
Shutdown Supply Current	I _{IN(off)}	0	—	10	μA	V _{IN} = 12V, I _O = 0A, V _{EN} = 0V	
SS Pin	Source current at low level voltage	(9) I _{EN/SS}	6	10	14	μA	V _{SS} = 0V, V _{IN} = 12V
	High level voltage	(9) V _{SSH}	—	3.0	—	V	V _{IN} = 12V
EN Pin	Sink current	I _{EN}	—	50	100	μA	V _{EN} = 10V
	Threshold voltage	V _{C/EH}	0.7	1.4	2.1	V	V _{IN} = 12V
Max on-duty	(10) D _{MAX}	—	90	—	%		
Minimum on-time	(10) (11) T _{ON(MIN)}	—	150	—	nsec		
Thermal shutdown threshold temperature	(10) TSD	151	165	—	°C		
Thermal shutdown restart hysteresis of temperature	(10) TSD_hys	—	20	—	°C		

(7) Electrical characteristics indicate specific limits, which are guaranteed when IC is operated under the measurement conditions shown above in the circuit diagram (refer to 4-3 (p.7)).

(8) Efficiency is calculated by the following equation.

(9) No.4 terminal is a EN/SS terminal to enable soft start by connecting a capacitor.

(10) This value is designed to guarantee value.

(11) The I/O characteristic graph of the figure below shows the I/O condition limited by the DMIN. Be effective only if output current is less than 100mA.

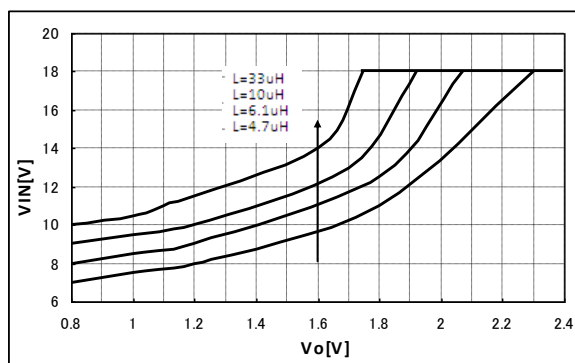

Typical Performance Characteristics

NR885K Typical Performance Characteristics

Efficiency

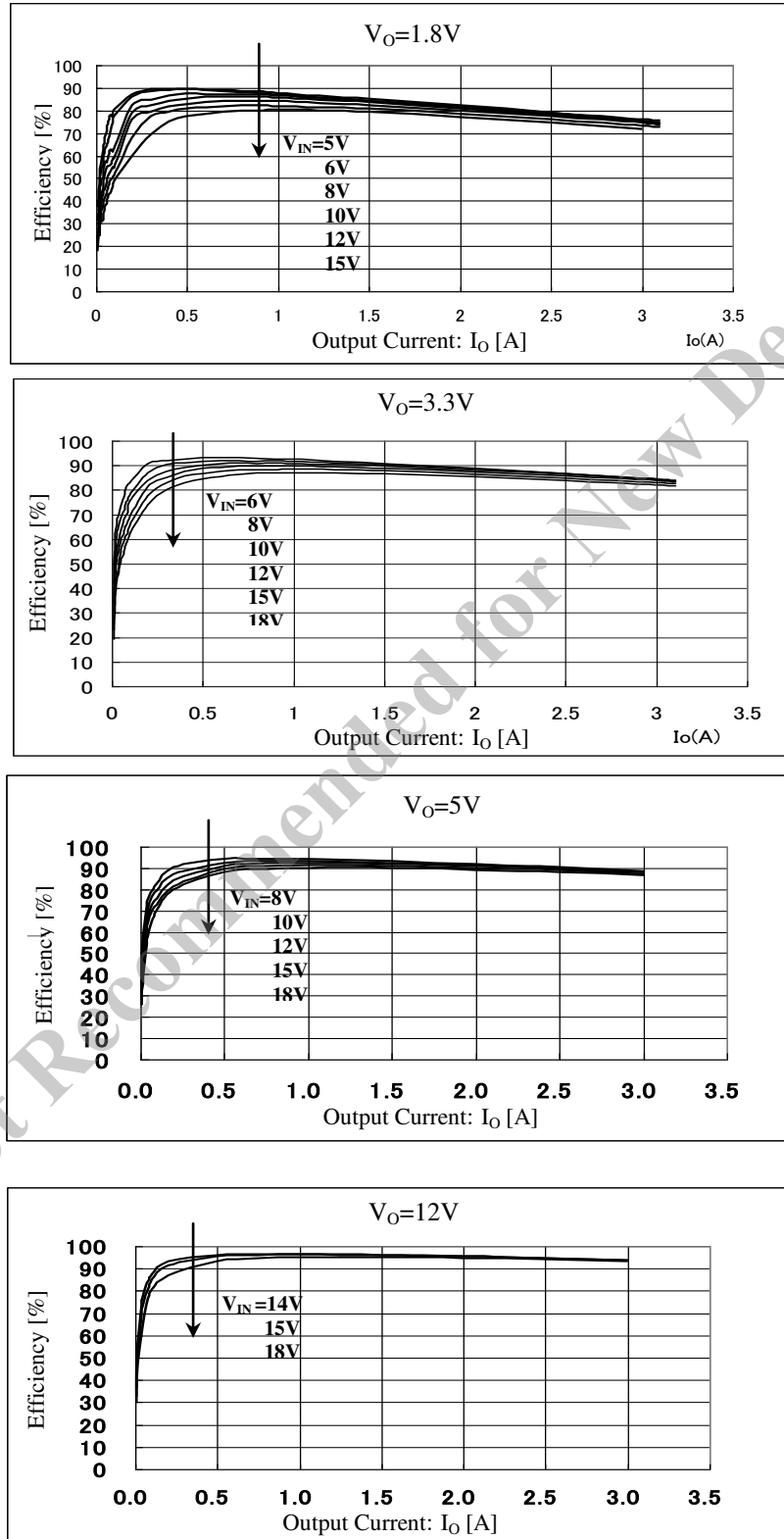

NR885K Typical Performance Characteristics

Output startup

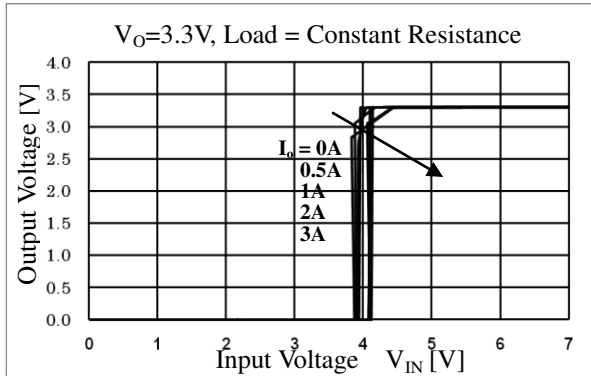

Over Current Protection

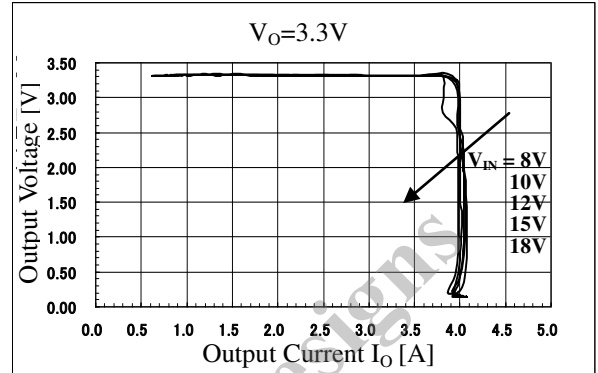

Load Regulation: V_{Load}

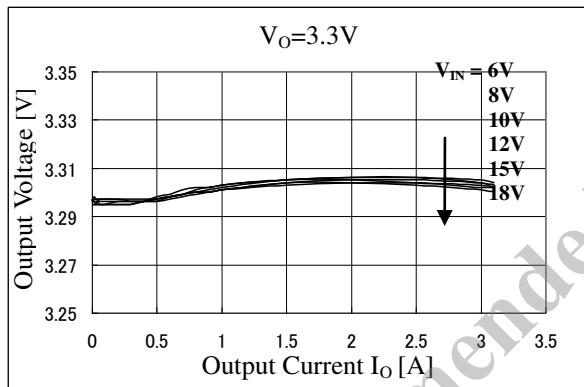

Quiescent Current

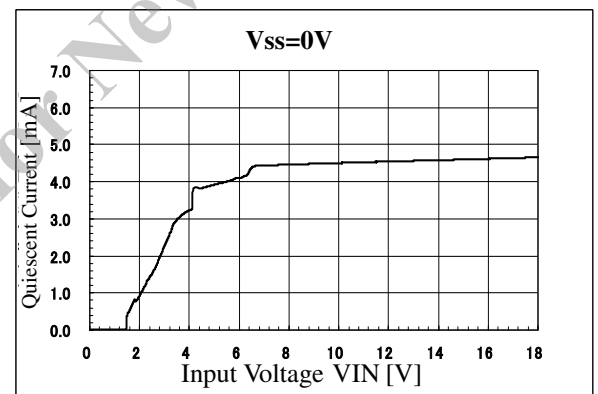

Shutdown Supply Current : $I_{IN(off)}$

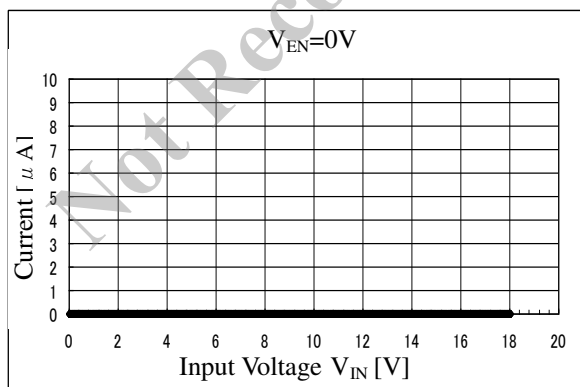

Supply Current : I_{IN}

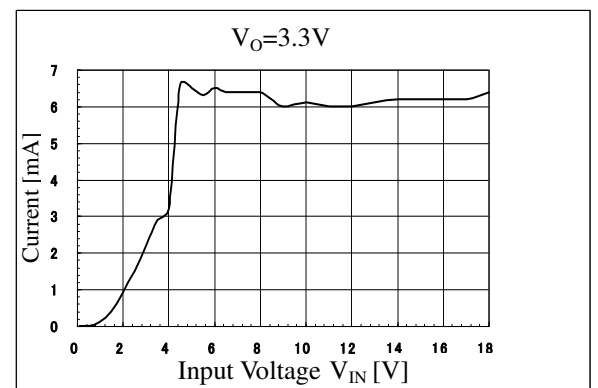

Switching Frequency: f_{SW}

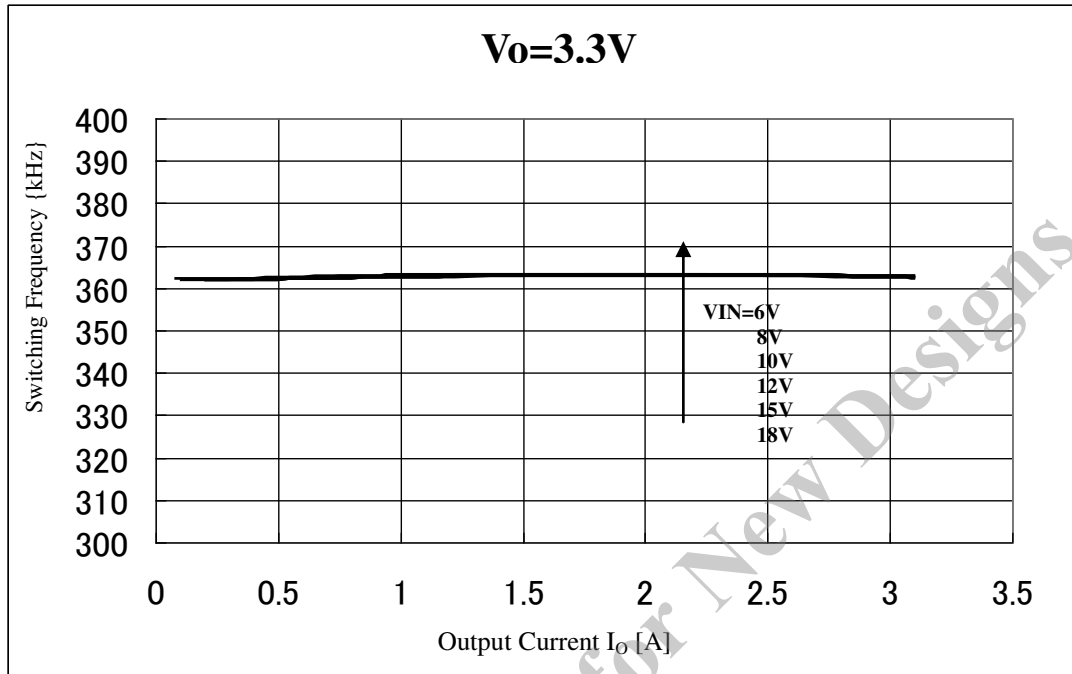

Not Recommended for New Designs

Functional Block Diagram

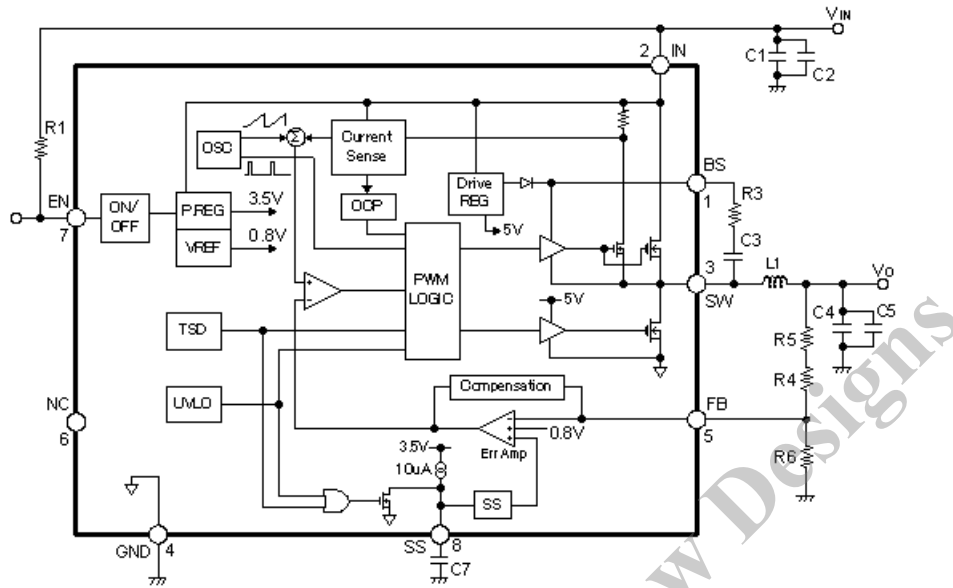

Allowable package power dissipation

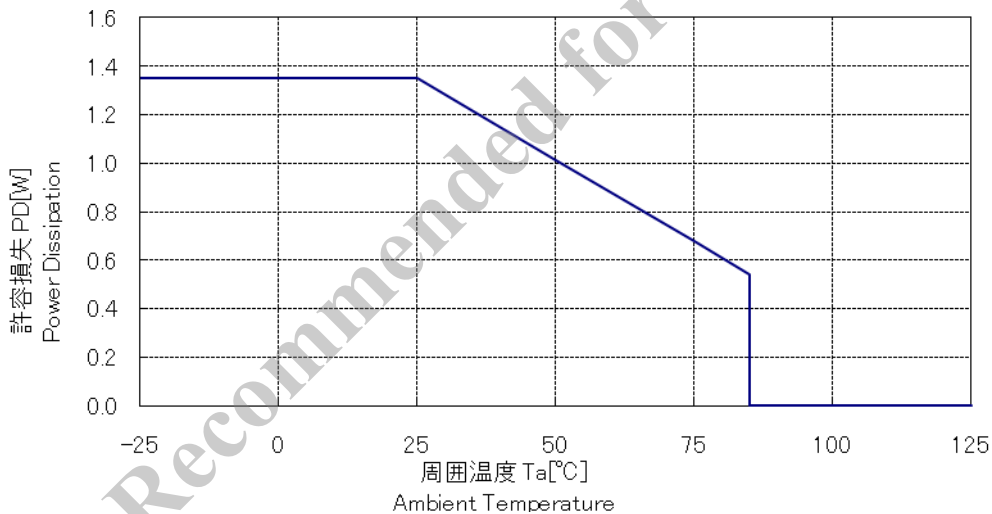

NOTES

- 1) Glass-epoxy board mounting in a 30×30mm
- 2) copper area : 25×25mm
- 3) The power dissipation is calculated at the junction temperature 125 °C
- 4) Losses can be calculated by the following equation.
As the efficiency is subject to the input voltage and output current, it shall be obtained from the efficiency curve and substituted in percent
- 5) Thermal design for D1 shall be made separately.

V_O: Output voltage

V_{IN}: Input voltage

I_O: Output current

η x : Efficiency (%)

$$P_D = V_O \times I_O \left(\frac{100}{\eta x} - 1 \right)$$

External Components Design Guide

(1) Diode D1

- Flywheel diode D1 can be connected to enhance the efficiency.
- The schottky-barrier diode must be used for D1. If other diodes like fast recovery diodes are used, IC may be damaged because of the reverse voltage applied by the recovery voltage or ON voltage.

(2) Choke coil L1

- If the winding resistance of the choke coil is too high, the efficiency may go down to the extent that it is out of the rating.
- As the start current of the over current protection is approximately 4A, attention must be paid to the heating of the choke coil by the magnetic saturation due to overload or short-circulated load.

(3) Capacitor C1(C2), C4(C5), C7

- As large ripple currents across C1 (C2) and C4 (C5), capacitors with high frequency and low impedance for SMPS must be used. Especially when the impedance of C4 (C5) is high, the switching waveform may not be normal at low temperature.
- C7 is a capacitor for soft start. A soft-start controls the over-shoot of the output voltage rising and rush current.

(4) Resistor R4, R5, R6

- R4, R5, R6 are resistor to the Output Voltage. I_{ADJ} is required to set to 0.2mA.
- R4, R5, R6 are calculated by the equation (1).

$$R4 + R5 = \frac{(V_O - V_{FB})}{I_{ADJ}} = \frac{(V_O - 0.8)}{0.2 \times 10^{-3}} (\Omega), \quad R6 = \frac{V_{FB}}{I_{ADJ}} = \frac{0.8}{0.2 \times 10^{-3}} \approx 4.0k(\Omega) \quad \text{----- (1)}$$

In order to have optimum operating condition, each component must be connected with the minimum distance.

PCB Layout & Recommended Land Pattern

- (1) Each ground of all components is connected as close as possible to the Pin No.4 at one point.
- (2) To help heat dissipation, connect a large copper plane to exposed pad on the back side of the package.
The copper plane is required for GND

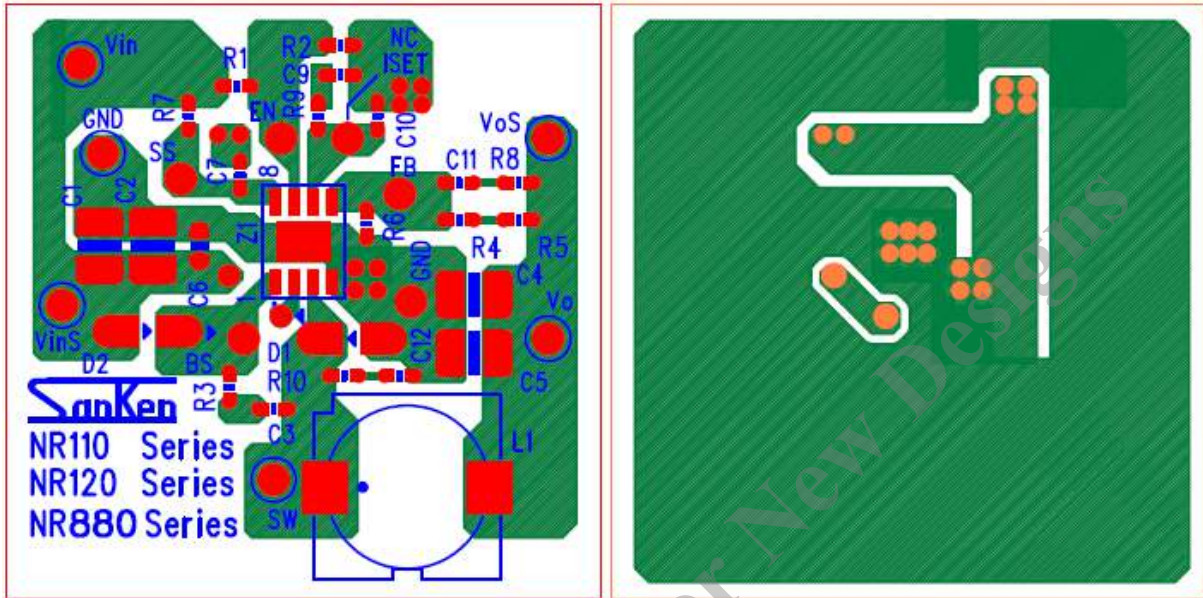

Front Side: Component Side (double sided board)

Back Side: GND Side (double sided board)

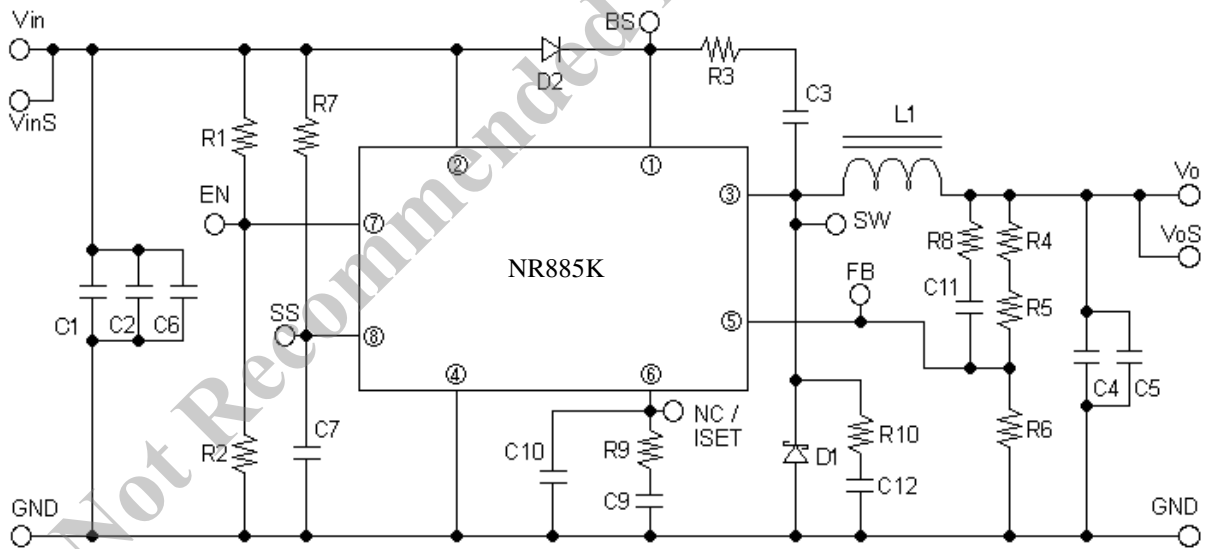

Demo-board circuit-diagram

As for the part number of the demonstration board "circuit-diagram", a circuit board concerned doesn't partly fit each other with the above application circuit example and so on for NR110, NR120 and the NR880 series common use. Approve it in advance. C9, R9 and C10 aren't used in the NR880 series. And, D1, D2, R3, R8,R10, C11 and C12 are options.

NOTES:

Real size of the PCB is 60mm×60mm

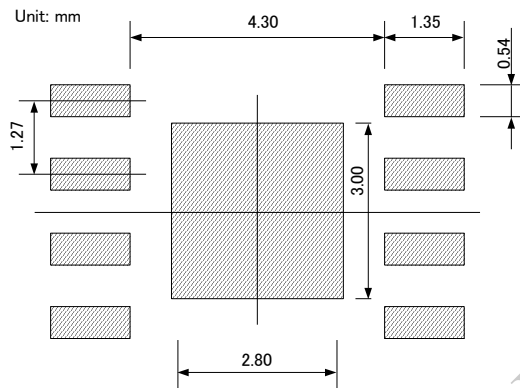

Recommended land pattern

Not Recommended for New Designs

Package Outline

HSOP8 package

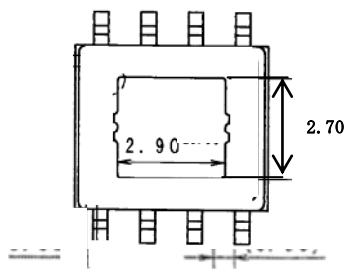
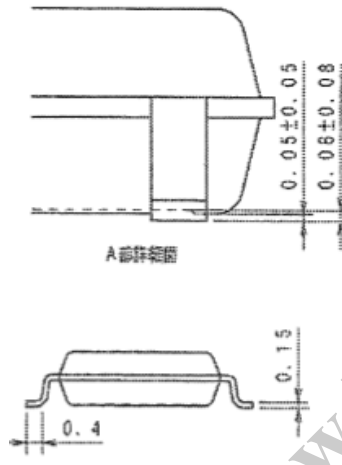
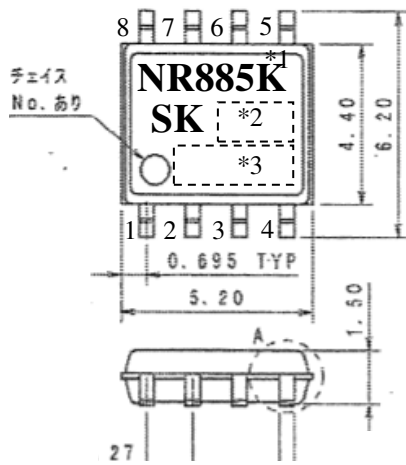

- *1.Type number
- *2.Lot number (three digit)
 - 1st letter The last digit of year
 - 2nd letter Month
 - 1 to 9 for Jan. to Sept.,
 - O for Oct. N for Nov. D for Dec.
 - 3rd letter week
 - 01~05 : Arabic Numerical
- *3.Control number (four digit)

PIN Assignment

- 1.BS
- 2.IN
- 3.SW
- 4.GND
- 5.FB
- 6.NC
- 7.EN
- 8.SS

Appearance

The body shall be clean and shall not bear any stain, rust or flaw.

Marking

The type number and lot number shall be marked on the body by laser which shall not be unreadable easily.

OPERATING PRECAUTIONS

Reliability can be affected adversely by improper storage environments and handling methods. Please observe the following cautions.

Heat dissipation and reliability

Thermal performance of the surface mount package IC depends on the material and area size of PCB and its copper plane. Design thermal condition with sufficient margin

Parallel operation

The parallel operation to increase the current is not available.

Thermal shut down

The NR111E has a thermal protection circuit.

This circuit protects the IC from the heat generation by the over load.

This circuit cannot guarantee the long-term reliability against the continuously over load status.

Cautions for Storage

- Ensure that storage conditions comply with the standard temperature (5 to 35°C) and the standard relative humidity (around 40 to 75%); avoid storage locations that experience extreme changes in temperature or humidity.
- Avoid locations where dust or harmful gases are present and avoid direct sunlight.
- Reinspect for rust on leads and solderability of products that have been stored for a long time.

Cautions for Testing and Handling

- When tests are carried out during inspection testing and other standard test periods, protect the products from power surges from the testing products, shorts between the product pins, and wrong connections. In addition, avoid tests exceeded ratings

Soldering

When soldering the products, please be sure to minimize the working time, within the following limits.

- Reflow Preheat ; 180°C / 90±30s
Heat ; 250°C / 10±1s (260°C peak ,2times)
- Soldering iron ; 380±10°C / 3.5±0.5s (1time)

Electrostatic Discharge

- When handling the products, the operator must be grounded. Grounded wrist straps worn should have at least 1MΩ of resistance from the operator to ground to prevent shock hazard, and it should be placed near the operator.
- Workbenches where the products are handled should be grounded and be provided with conductive table and floor mats.
- When using measuring equipment such as a curve tracer, the equipment should be grounded.
- When soldering the products, the head of a soldering irons or the solder bath must be grounded in order to prevent leak voltages generated by them from being applied to the products.
- The products should always be stored and transported in Sanken shipping containers or conductive containers, or be wrapped in aluminum foil.

IMPORTANT NOTES

- The contents in this document are subject to changes, for improvement and other purposes, without notice. Make sure that this is the latest revision of the document before use.
- Application and operation examples described in this document are quoted for the sole purpose of reference for the use of the products herein and Sanken can assume no responsibility for any infringement of industrial property rights, intellectual property rights or any other rights of Sanken or any third party which may result from its use.
- Although Sanken undertakes to enhance the quality and reliability of its products, the occurrence of failure and defect of semiconductor products at a certain rate is inevitable. Users of Sanken products are requested to take, at their own risk, preventative measures including safety design of the equipment or systems against any possible injury, death, fires or damages to the society due to device failure or malfunction.
- Sanken products listed in this document are designed and intended for the use as components in general purpose electronic equipment or apparatus (home appliances, office equipment, telecommunication equipment, measuring equipment, etc.).
When considering the use of Sanken products in the applications where higher reliability is required (transportation equipment and its control systems, traffic signal control systems or equipment, fire/crime alarm systems, various safety devices, etc.), please contact your nearest Sanken sales representative to discuss, prior to the use of the products herein.
The use of Sanken products without the written consent of Sanken in the applications where extremely high reliability is required (aerospace equipment, nuclear power control systems, life support systems, etc.) is strictly prohibited.
- In the case that you use Sanken semiconductor products or design your products by using Sanken semiconductor products, the reliability largely depends on the degree of derating to be made to the rated values. Derating may be interpreted as a case that an operation range is set by derating the load from each rated value or surge voltage or noise is considered for derating in order to assure or improve the reliability. In general, derating factors include electric stresses such as electric voltage, electric current, electric power etc., environmental stresses such as ambient temperature, humidity etc. and thermal stress caused due to self-heating of semiconductor products. For these stresses, instantaneous values, maximum values and minimum values must be taken into consideration.
In addition, it should be noted that since power devices or IC's including power devices have large self-heating value, the degree of derating of junction temperature affects the reliability significantly.
- When using the products specified herein by either (i) combining other products or materials therewith or (ii) physically, chemically or otherwise processing or treating the products, please duly consider all possible risks that may result from all such uses in advance and proceed therewith at your own responsibility.
- Anti radioactive ray design is not considered for the products listed herein.
- Sanken assumes no responsibility for any troubles, such as dropping products caused during transportation out of Sanken's distribution network.
- The contents in this document must not be transcribed or copied without Sanken's written consent.