



# 18-Bit Analog-to-Digital Converter for Bridge Sensors

Check for Samples: [ADS1131](#)

## FEATURES

- Complete Front-End for Bridge Sensors
- Available in an SO Package
- Internal Amplifier, Gain of 64
- Internal Oscillator
- Low-Side Power Switch for Bridge Sensor
- 18-Bit Noise-Free Resolution
- Selectable 10SPS or 80SPS Data Rates
- Simultaneous 50Hz and 60Hz Rejection at 10SPS
- External Voltage Reference up to 5V for Ratiometric Measurements
- Simple, Pin-Driven Control
- Two-Wire Serial Digital Interface
- Supply Range: 3V to 5.3V
- $-40^{\circ}\text{C}$  to  $+85^{\circ}\text{C}$  Temperature Range

## APPLICATIONS

- Weigh Scales
- Strain Gauges
- Load Cells
- Industrial Process Control

## DESCRIPTION

The ADS1131 is a precision, 18-bit analog-to-digital converter (ADC). With an onboard, low-noise amplifier, onboard oscillator, precision 18-bit delta-sigma ( $\Delta\Sigma$ ) ADC, and bridge power switch, the ADS1131 provides a complete front-end solution for bridge sensor applications including weigh scales, strain gauges, and load cells.

The low-noise amplifier has a gain of 64, supporting a full-scale differential input of  $\pm 39\text{mV}$ . The  $\Delta\Sigma$  ADC has 18-bit effective resolution and is comprised of a third-order modulator and fourth-order digital filter. Two data rates are supported: 10SPS (with both 50Hz and 60Hz rejection) and 80SPS. The ADS1131 can be put into a low-power standby mode or shut off completely in power-down mode.

The ADS1131 is controlled by dedicated pins; there are no digital registers to program. Data are output over an easily-isolated serial interface that connects directly to the MSP430 and other microcontrollers.

The ADS1131 is available in an SO-16 package and is specified from  $-40^{\circ}\text{C}$  to  $+85^{\circ}\text{C}$ .

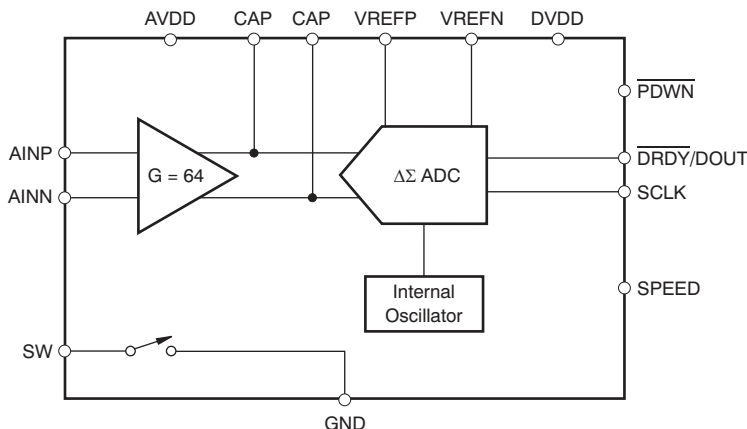

Please be aware that an important notice concerning availability, standard warranty, and use in critical applications of Texas Instruments semiconductor products and disclaimers thereto appears at the end of this data sheet.

All trademarks are the property of their respective owners.



This integrated circuit can be damaged by ESD. Texas Instruments recommends that all integrated circuits be handled with appropriate precautions. Failure to observe proper handling and installation procedures can cause damage.

ESD damage can range from subtle performance degradation to complete device failure. Precision integrated circuits may be more susceptible to damage because very small parametric changes could cause the device not to meet its published specifications.

### PACKAGE AND ORDERING INFORMATION<sup>(1)</sup>

- (1) For the most current package and ordering information, see the Package Option Addendum at the end of this document, or visit the device product folder at [www.ti.com](http://www.ti.com).

### ABSOLUTE MAXIMUM RATINGS<sup>(1)</sup>

Over operating free-air temperature range, unless otherwise noted.

	ADS1131	UNIT
AVDD to GND	-0.3 to +6	V
DVDD to GND	-0.3 to +6	V
Input current	100, momentary	mA
	10, continuous	mA
Analog input voltage to GND	-0.3 to AVDD + 0.3	V
Digital input voltage to GND	-0.3 to DVDD + 0.3	V
Maximum junction temperature	+150	°C
Operating temperature range	-40 to +85	°C
Storage temperature range	-60 to +150	°C

- (1) Stresses beyond those listed under *Absolute Maximum Ratings* may cause permanent damage to the device. These are stress ratings only, and functional operation of the device at these or any other conditions beyond those indicated is not implied. Exposure to absolute-maximum-rated conditions for extended periods may affect device reliability.

## ELECTRICAL CHARACTERISTICS

Minimum/maximum limit specifications apply from  $-40^{\circ}\text{C}$  to  $+85^{\circ}\text{C}$ . Typical specifications at  $+25^{\circ}\text{C}$ .  
 All specifications at  $\text{AVDD} = \text{DVDD} = \text{VREFP} = +5\text{V}$ , and  $\text{VREFN} = \text{GND}$ , unless otherwise noted.

PARAMETER	CONDITIONS	ADS1131			UNIT
		MIN	TYP	MAX	
<b>ANALOG INPUTS</b>					
Full-scale input voltage ( $\text{AINP} - \text{AINN}$ )		$\pm 0.5V_{\text{REF}}/64$			V
	$V_{\text{REF}} = \text{AVDD} = 5\text{V}$	$\pm 39.0$			mV
	$V_{\text{REF}} = \text{AVDD} = 3\text{V}$	$\pm 23.4$			mV
Common-mode input range		$\text{GND} + 1.5\text{V}$		$\text{AVDD} - 1.5\text{V}$	V
Differential input current		$\pm 2$			nA
<b>LOW-SIDE POWER SWITCH</b>					
On-resistance ( $R_{\text{ON}}$ )	$\text{AVDD} = 5\text{V}$ , $I_{\text{SW}} = 30\text{mA}$		3.5	5	$\Omega$
	$\text{AVDD} = 3\text{V}$ , $I_{\text{SW}} = 30\text{mA}$		4	7	$\Omega$
Current through switch				30	mA
<b>SYSTEM PERFORMANCE</b>					
Resolution	No missing codes	18			Bits
Data rate	SPEED = high	80			SPS
	SPEED = low	10			SPS
Digital filter settling time	Full settling	4			Conversions
Integral nonlinearity (INL)	Differential input, end-point fit	$\pm 8$			ppm
Input offset error		10			$\mu\text{V}$
Input offset drift		$\pm 15$			$\text{nV}/^{\circ}\text{C}$
Gain error		1			%
Gain drift		$\pm 4$			$\text{ppm}/^{\circ}\text{C}$
Normal-mode rejection	$f_{\text{IN}} = 50\text{Hz}$ or $60\text{Hz} \pm 1\text{Hz}$ , $f_{\text{DATA}} = 10\text{SPS}$	90			dB
Common-mode rejection	At dc	110			dB
Noise (peak-to-peak)	$f_{\text{DATA}} = 10\text{SPS}$ , $\text{AVDD} = V_{\text{REF}} = 5\text{V}$	1			LSB
	$f_{\text{DATA}} = 80\text{SPS}$ , $\text{AVDD} = V_{\text{REF}} = 5\text{V}$	1.7			LSB
	$f_{\text{DATA}} = 10\text{SPS}$ , $\text{AVDD} = V_{\text{REF}} = 5\text{V}$	300			nV
	$f_{\text{DATA}} = 80\text{SPS}$ , $\text{AVDD} = V_{\text{REF}} = 5\text{V}$	500			nV
Power-supply rejection	At dc	100			dB
<b>VOLTAGE REFERENCE INPUT</b>					
Voltage reference input ( $V_{\text{REF}}$ )	$V_{\text{REF}} = \text{VREFP} - \text{VREFN}$	1.5	AVDD	$\text{AVDD} + 0.1\text{V}$	V
Negative reference input ( $V_{\text{REFN}}$ )		$\text{AGND} - 0.1$		$\text{VREFP} - 1.5$	V
Positive reference input ( $V_{\text{REFP}}$ )		$\text{VREFN} + 1.5$		$\text{AVDD} + 0.1$	V
Voltage reference input current		10			nA
<b>DIGITAL INPUT/OUTPUT (DVDD = 2.7V to 5.3V)</b>					
Logic levels	$V_{\text{IH}}$		$0.8 \text{ DVDD}$	$\text{DVDD} + 0.1$	V
	$V_{\text{IL}}$		GND	$0.2 \text{ DVDD}$	V
	$V_{\text{OH}}$	$I_{\text{OH}} = 500\mu\text{A}$	$\text{DVDD} - 0.4$		V
	$V_{\text{OL}}$	$I_{\text{OL}} = 500\mu\text{A}$		$0.2 \text{ DVDD}$	V
Input leakage	$0 < V_{\text{DIGITAL INPUT}} < \text{DVDD}$	$\pm 10$			$\mu\text{A}$
Serial clock input frequency ( $f_{\text{SCLK}}$ )		5			MHz

### ELECTRICAL CHARACTERISTICS (continued)

Minimum/maximum limit specifications apply from –40°C to +85°C. Typical specifications at +25°C. All specifications at AVDD = DVDD = VREFP = +5V, and VREFN = GND, unless otherwise noted.

PARAMETER	CONDITIONS	ADS1131			UNIT
		MIN	TYP	MAX	
<b>POWER SUPPLY</b>					
Power-supply voltage (AVDD, DVDD)		3		5.3	V
Analog supply current	Normal mode, AVDD = 3V		900		μA
	Normal mode, AVDD = 5V		900		μA
	Standby mode		0.1		μA
	Power-down		0.1		μA
Digital supply current	Normal mode, DVDD = 3V		60		μA
	Normal mode, DVDD = 5V		95		μA
	Standby mode, SCLK = high, DVDD = 3V		45		μA
	Standby mode, SCLK = high, DVDD = 5V		65		μA
	Power-down		0.2		μA
Power dissipation, total	Normal mode, AVDD = DVDD = 3V		2.9		mW
	Normal mode, AVDD = DVDD = 5V		5.0		mW
<b>TEMPERATURE</b>					
Operating temperature range		–40		+85	°C
Specified temperature range		–40		+85	°C

### THERMAL INFORMATION

THERMAL METRIC <sup>(1)</sup>		ADS1131D	UNITS
		D	
		16 PINS	
$\theta_{JA}$	Junction-to-ambient thermal resistance	133.8	°C/W
$\theta_{JC(top)}$	Junction-to-case(top) thermal resistance	71.4	
$\theta_{JB}$	Junction-to-board thermal resistance	60.0	
$\Psi_{JT}$	Junction-to-top characterization parameter	17.4	
$\Psi_{JB}$	Junction-to-board characterization parameter	53.3	
$\theta_{JC(bottom)}$	Junction-to-case(bottom) thermal resistance	n/a	

(1) For more information about traditional and new thermal metrics, see the *IC Package Thermal Metrics* application report, [SPRA953](#).

## PIN CONFIGURATION

**D PACKAGE  
SO-16  
(TOP VIEW)**

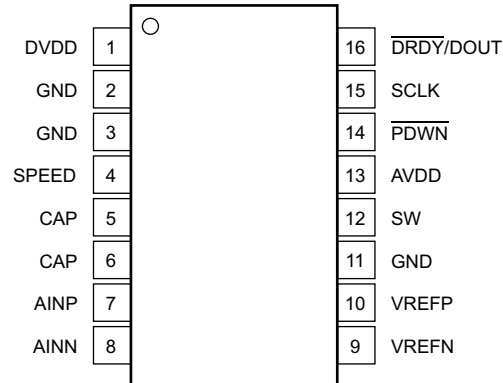

## PIN DESCRIPTIONS

NAME	TERMINAL	ANALOG/DIGITAL INPUT/OUTPUT	DESCRIPTION	
DVDD	1	Digital	Digital power supply	
GND	2	Supply	Ground for digital and analog supplies	
GND	3	Supply	Ground for digital and analog supplies	
SPEED	4	Digital input	Data rate select:	
			<b>SPEED</b>	<b>DATA RATE</b>
			0	10SPS
			1	80SPS
CAP	5	Analog	Gain amplifier bypass capacitor connection	
CAP	6	Analog	Gain amplifier bypass capacitor connection	
AINP	7	Analog input	Positive analog input	
AINN	8	Analog input	Negative analog input	
VREFN	9	Analog input	Negative reference input	
VREFP	10	Analog input	Positive reference input	
GND	11	Supply	Ground for digital and analog supplies	
SW	12	Analog	Low-side power switch	
AVDD	13	Supply	Analog power supply	
PDWN	14	Digital input	Power-down: holding this pin low powers down the entire converter and resets the ADC.	
SCLK	15	Digital input	Serial clock: clock out data on the rising edge. Also used to initiate Standby mode. See the <a href="#">Standby Mode</a> section for more details.	
DRDY/DOOUT	16	Digital output	Dual-purpose output: Data ready: indicates valid data by going low. Data output: outputs data, MSB first, on the first rising edge of SCLK.	

## OVERVIEW

The ADS1131 is a precision, 18-bit ADC that includes a low-noise PGA, internal oscillator, third-order delta-sigma ( $\Delta\Sigma$ ) modulator, and fourth-order digital filter. The ADS1131 provides a complete front-end solution for bridge sensor applications such as weigh scales, strain gauges, and pressure sensors.

Data can be output at 10SPS for excellent 50Hz and 60Hz rejection, or at 80SPS when higher speeds are needed. The ADS1131 is easy to configure, and all digital control is accomplished through dedicated pins; there are no registers to program. A simple two-wire serial interface retrieves the data.

### ANALOG INPUTS (AINP, AINN)

The input signal to be measured is applied to the input pins AINP and AINN. The ADS1131 accepts differential input signals, but can also measure unipolar signals. When measuring unipolar (or single-ended signals) with respect to ground, connect the negative input (AINN) to ground and connect the input signal to the positive input (AINP). Note that when the ADS1131 is configured this way, only half of the converter full-scale range is used, because only positive digital output codes are produced.

### LOW-NOISE AMPLIFIER

The ADS1131 features a low-drift, low-noise amplifier that provides a complete front-end solution for bridge sensors. A simplified diagram of the amplifier is shown in [Figure 1](#). It consists of two chopper-stabilized amplifiers (A1 and A2) and three accurately matched resistors ( $R_1$ ,  $R_{F1}$ , and  $R_{F2}$ ) that construct a differential front-end stage with a gain of 64, followed by gain stage A3 (Gain = 1). The inputs are equipped with an EMI filter, as shown in [Figure 1](#). The cutoff frequency of the EMI filter is 20MHz. By using AVDD as the reference input, the bipolar input ranges from

–39mV to +39mV, and the unipolar input ranges from 0mV to +39mV. The inputs of the ADS1131 are protected with internal diodes connected to the power-supply rails. These diodes clamp the applied signal to prevent it from damaging the input circuitry.

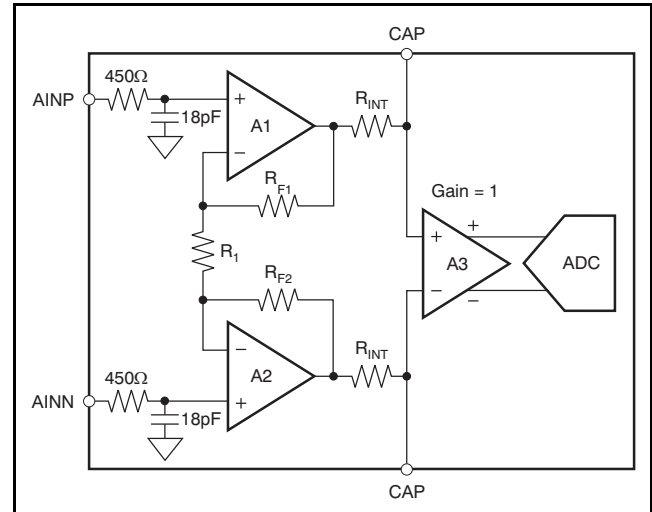

**Figure 1. Simplified Diagram of the Amplifier**

### External Capacitor

An external capacitor ( $C_{EXT}$ ) across the ADS1131 two CAP pins combines with the internal resistor  $R_{INT}$  (on-chip) to create a low-pass filter. The recommended value for  $C_{EXT}$  is 0.1μF which provides a corner frequency of 720Hz. This low-pass filter serves two purposes. First, the input signal is bandlimited to prevent aliasing by the ADC and to filter out the high-frequency noise. Second, it attenuates the chopping residue from the amplifier to improve temperature drift performance. NPO or C0G capacitors are recommended. For optimal performance, place the external capacitor very close to the CAP pins.

### VOLTAGE REFERENCE INPUTS (VREFP, VREFN)

The voltage reference used by the modulator is generated from the voltage difference between VREFP and VREFN:  $V_{REF} = VREFP - VREFN$ . The reference inputs use a structure similar to that of the analog inputs. In order to increase the reference input impedance, a switching buffer circuitry is used to reduce the input equivalent capacitance. The reference drift and noise impact ADC performance. In order to achieve best results, pay close attention to the reference noise and drift specifications. A simplified diagram of the circuitry on the reference inputs is shown in Figure 2. The switches and capacitors can be modeled approximately using an effective impedance of:

$$Z_{EFF} = 500M\Omega$$

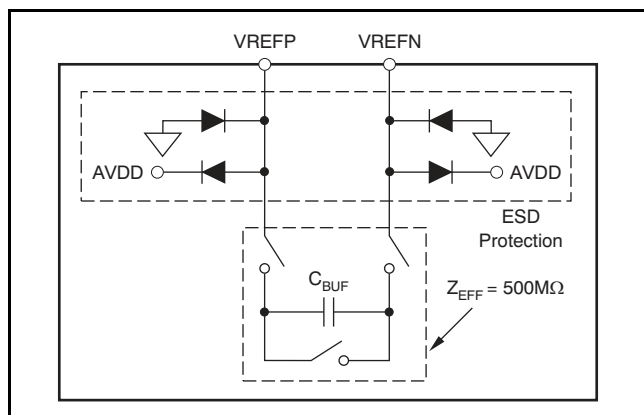

**Figure 2. Simplified Reference Input Circuitry**

ESD diodes protect the reference inputs. To prevent these diodes from turning on, make sure the voltages on the reference pins do not go below GND by more than 100mV, and likewise, do not exceed AVDD by 100mV:

$$GND - 100mV < (VREFP \text{ or } VREFN) < AVDD + 100mV$$

### LOW-SIDE POWER SWITCH (SW)

The ADS1131 incorporates an internal switch for use with an external bridge sensor, as shown in Figure 3. The switch can be used in a return path for the bridge power. By opening the switch, power dissipation in the bridge is eliminated.

The switch is controlled by the ADS1131 conversion status. During normal conversions, the switch is closed (the SW pin is connected to GND). During standby or power-down modes, the switch is opened (the SW pin is high impedance). When using the switch, it is recommended that the negative reference input (VREFN) be connected directly to the bridge ground terminal, as shown in Figure 3 for best performance.

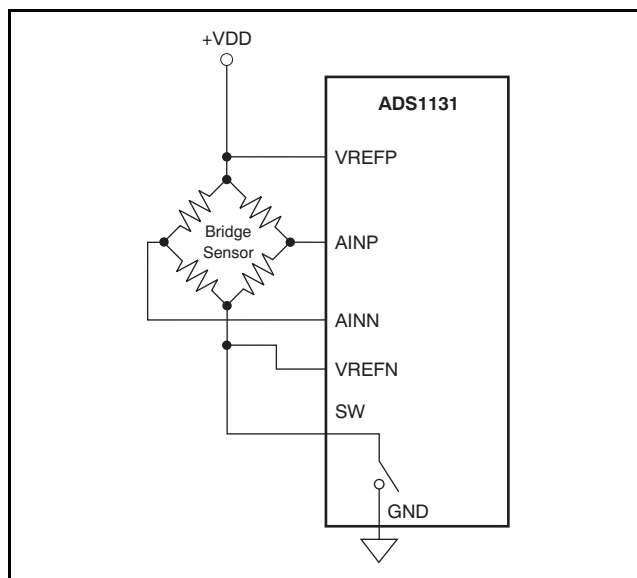

**Figure 3. Low-Side Power Switch**

### CLOCK SOURCE

The ADS1131 uses an internal oscillator. No external clock circuitry is required.

### FREQUENCY RESPONSE

The ADS1131 uses a sinc<sup>4</sup> digital filter with the frequency response. The frequency response repeats at multiples of the modulator sampling frequency of 76.8kHz. The overall response is that of a low-pass filter with a -3dB cutoff frequency of 3.32Hz with the SPEED pin tied low (10SPS data rate) and 11.64Hz with the SPEED pin tied high (80SPS data rate).

To help see the response at lower frequencies, Figure 4(a) illustrates the nominal response out to 100Hz, when the data rate = 10SPS. Notice that signals at multiples of 10Hz are rejected, and therefore simultaneous rejection of 50Hz and 60Hz is achieved.

The benefit of using a sinc<sup>4</sup> filter is that every frequency notch has four zeros on the same location. This response, combined with the low drift internal oscillator, provides an excellent normal-mode rejection of line-cycle interference.

Figure 4(b) zooms in on the 50Hz and 60Hz notches with the SPEED pin tied low (10SPS data rate).

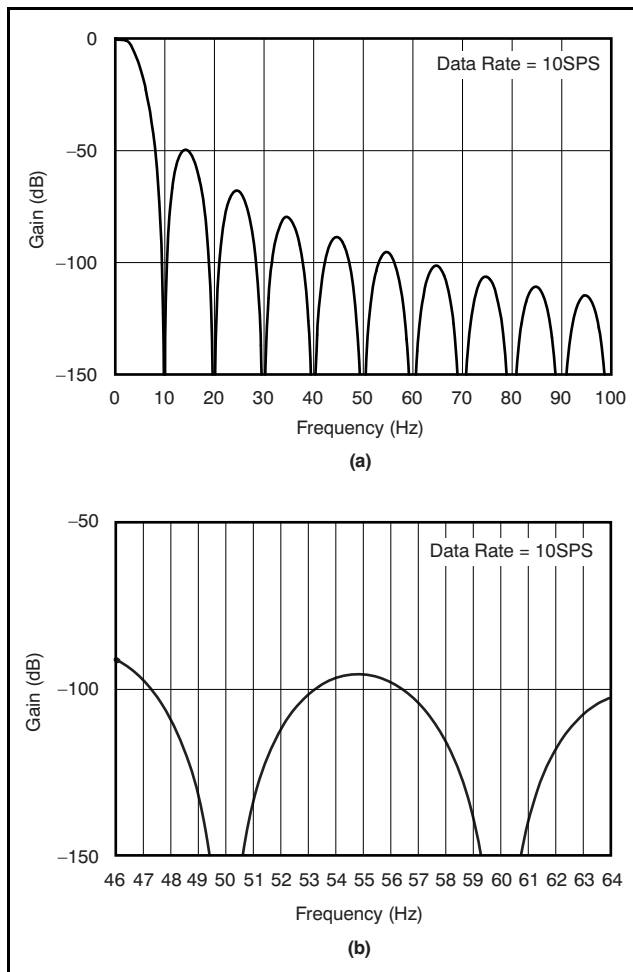

Figure 4. Nominal Frequency Response Out To 100Hz



## SETTLING TIME

Fast changes in the input signal require time to settle. For example, an external multiplexer in front of the ADS1131 can generate abrupt changes in input voltage by simply switching the multiplexer input channels. These sorts of changes in the input require four data conversion cycles to settle. When continuously converting, five readings may be necessary in order to settle the data. If the change in input occurs in the middle of the first conversion, four more full conversions of the fully-settled input are required to obtain fully-settled data. Discard the first four readings because they contain only partially-settled data. Figure 5 illustrates the settling time for the ADS1131.

## DATA RATE

The ADS1131 data rate is set by the SPEED pin, as shown in Table 1. When SPEED is low, the data rate is nominally 10SPS. This data rate provides the lowest noise, and also has excellent rejection of both 50Hz and 60Hz line-cycle interference. For applications requiring fast data rates, setting SPEED high selects a data rate of nominally 80SPS.

**Table 1. Data Rate Settings**

SPEED PIN	DATA RATE
0	10SPS
1	80SPS

## DATA FORMAT

The ADS1131 outputs 18 bits of data in binary two's complement format. The least significant bit (LSB) has a weight of  $(0.5V_{REF}/64)(2^{17} - 1)$ . The positive full-scale input produces an output code of 1FFFFh and the negative full-scale input produces an output code of 20000h. The output clips at these codes for signals exceeding full-scale. Table 2 summarizes the ideal output codes for different input signals.

**Table 2. Ideal Output Code vs Input Signal**

INPUT SIGNAL $V_{IN}$ ( $A_{INP} - A_{INN}$ )	IDEAL OUTPUT
$\geq +0.5V_{REF}/64$	1FFFFh
$(+0.5V_{REF}/64)/(2^{17} - 1)$	00001h
0	00000h
$(-0.5V_{REF}/64)/(2^{17} - 1)$	3FFFFh
$\leq -0.5V_{REF}/64$	20000h

1. Excludes effects of noise, INL, offset, and gain errors.

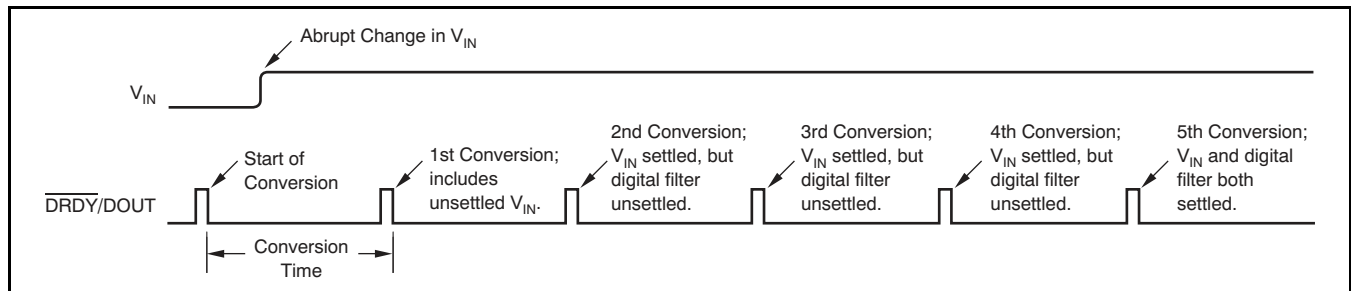
**Figure 5. Settling Time in Continuous Conversion Mode**

### DATA READY/DATA OUTPUT ( $\overline{\text{DRDY}}/\text{DOUT}$ )

This digital output pin serves two purposes. First, it indicates when new data are ready by going low. Afterwards, on the first rising edge of SCLK, the  $\overline{\text{DRDY}}/\text{DOUT}$  pin changes function and begins outputting the conversion data, most significant bit (MSB) first. Data are shifted out on each subsequent SCLK rising edge. After all 18 bits have been retrieved, the pin can be forced high with an additional SCLK. It then stays high until new data are ready. This configuration is useful when polling on the status of  $\overline{\text{DRDY}}/\text{DOUT}$  to determine when to begin data retrieval.

### SERIAL CLOCK INPUT (SCLK)

This digital input shifts serial data out with each rising edge. This input has built-in hysteresis, but care should still be taken to ensure a clean signal. Glitches or slow-rising signals can cause unwanted additional shifting. For this reason, it is best to make sure the rise and fall times of SCLK are both less than 50ns.

### DATA RETRIEVAL

The ADS1131 continuously converts the analog input signal. To retrieve data, wait until  $\overline{\text{DRDY}}/\text{DOUT}$  goes low, as shown in Figure 6. After  $\overline{\text{DRDY}}/\text{DOUT}$  goes low, begin shifting out the data by applying SCLKs. Data are shifted out MSB first. It is not required to shift out all 18 bits of data, but the data must be retrieved before new data are updated (within  $t_{\text{CONV}}$ ) or else the data will be overwritten. Avoid data retrieval during the update period ( $t_{\text{UPDATE}}$ ). If only 18 SCLKs have been applied,  $\overline{\text{DRDY}}/\text{DOUT}$  remains at the state of the last bit shifted out until it is taken high (see  $t_{\text{UPDATE}}$ ), indicating that new data are being updated. To avoid having  $\overline{\text{DRDY}}/\text{DOUT}$  remain in the state of the last bit, the 19th SCLK can be applied to force  $\overline{\text{DRDY}}/\text{DOUT}$  high, as shown in Figure 7. This technique is useful when a host controlling the device is polling  $\overline{\text{DRDY}}/\text{DOUT}$  to determine when data are ready.

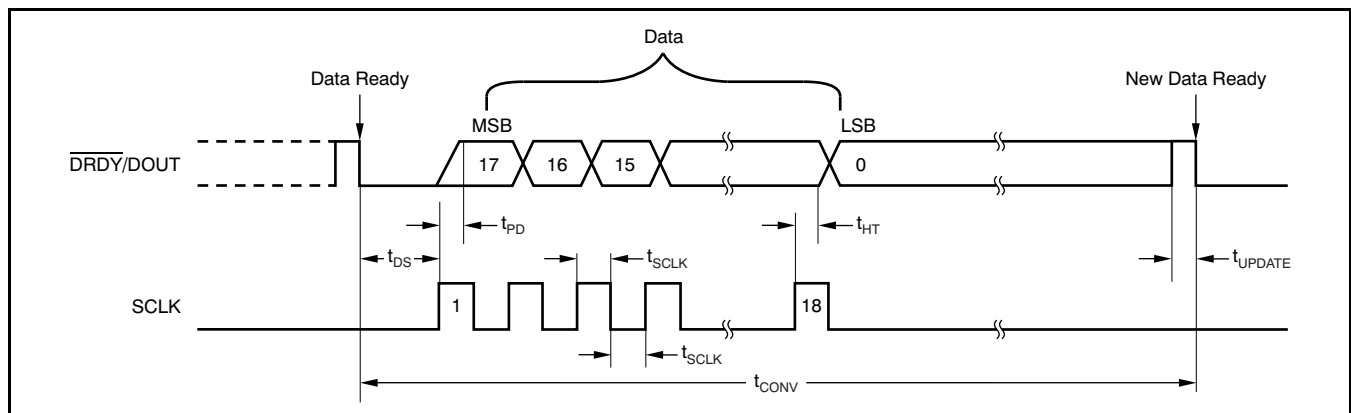

Figure 6. 18-Bit Data Retrieval Timing

SYMBOL	DESCRIPTION	MIN	TYP	MAX	UNITS
$t_{\text{DS}}$	$\overline{\text{DRDY}}/\text{DOUT}$ low to first SCLK rising edge	0			ns
$t_{\text{SCLK}}$	SCLK positive or negative pulse width	100			ns
$t_{\text{PD}}^{(1)}$	SCLK rising edge to new data bit valid: propagation delay			50	ns
$t_{\text{HT}}^{(1)}$	SCLK rising edge to old data bit valid: hold time	20			ns
$t_{\text{UPDATE}}$	Data updating: no readback allowed		90		$\mu\text{s}$
$t_{\text{CONV}}$	Conversion time (1/data rate)	SPEED = 1	12.5		ms
		SPEED = 0	100		ms

(1) Minimum required from simulation.

## STANDBY MODE

Standby mode dramatically reduces power consumption by shutting down most of the circuitry. In Standby mode, the entire analog circuitry is powered down and only the clock source circuitry is awake to reduce the wake-up time from the Standby mode. To enter Standby mode, simply hold SCLK high after  $\overline{\text{DRDY}}/\text{DOUT}$  goes low; see Figure 8. Standby mode can be initiated at any time during readback; it is not necessary to retrieve all 18 bits of data beforehand.

When  $t_{\text{STANDBY}}$  has passed with SCLK held high, Standby mode activates.  $\overline{\text{DRDY}}/\text{DOUT}$  stays high when Standby mode begins. SCLK must remain high to stay in Standby mode. To exit Standby mode (wakeup), set SCLK low. The first data after exiting Standby mode are valid.

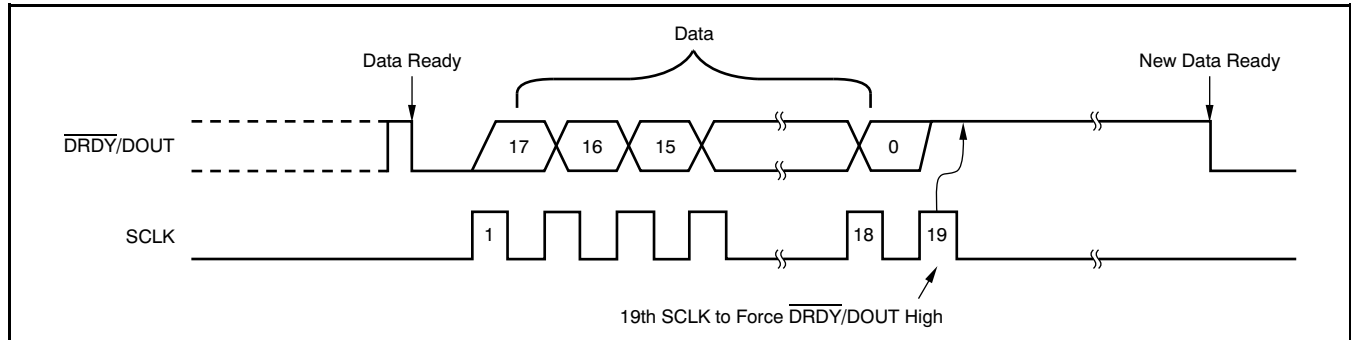

Figure 7. Data Retrieval with  $\overline{\text{DRDY}}/\text{DOUT}$  Forced High Afterwards

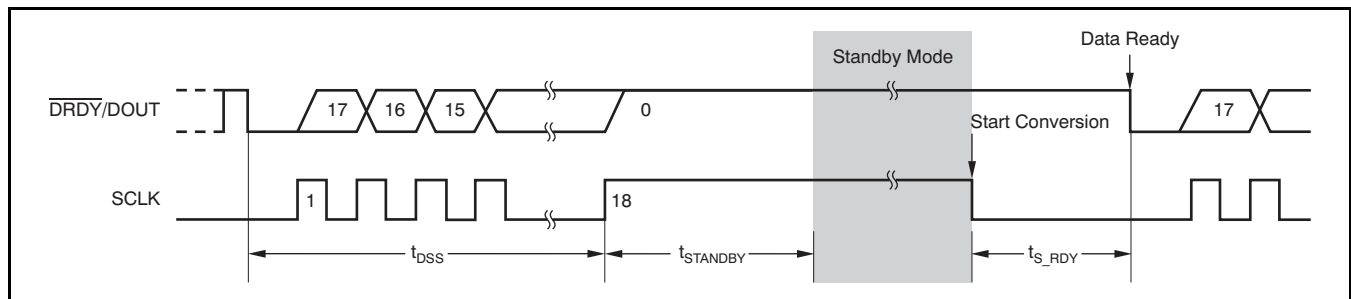

Figure 8. Standby Mode Timing (Can be used for single conversions)

SYMBOL	DESCRIPTION		MIN	TYP	MAX	UNITS
$t_{\text{DSS}}^{(1)}$	SCLK high after $\overline{\text{DRDY}}/\text{DOUT}$ goes low to activate Standby mode	SPEED = 1			12.44	ms
		SPEED = 0			99.94	ms
$t_{\text{STANDBY}}$	Standby mode activation time	SPEED = 1	0.0125			s
		SPEED = 0	0.1			s
$t_{\text{S\_RDY}}^{(1)}$	Data ready after exiting Standby mode	SPEED = 1	No change (typical time required)			ms
		SPEED = 0		401.8		ms

(1) Based on an ideal internal oscillator.

### POWER-DOWN MODE

Power-Down mode shuts down the entire ADC circuitry and reduces the total power consumption close to zero. To enter Power-Down mode, simply hold the PDWN pin low.

Power-Down mode also resets the entire circuitry. Power-Down mode can be initiated at any time during readback; it is not necessary to retrieve all 18 bits of data beforehand. Figure 9 shows the wake-up timing from Power-Down mode.

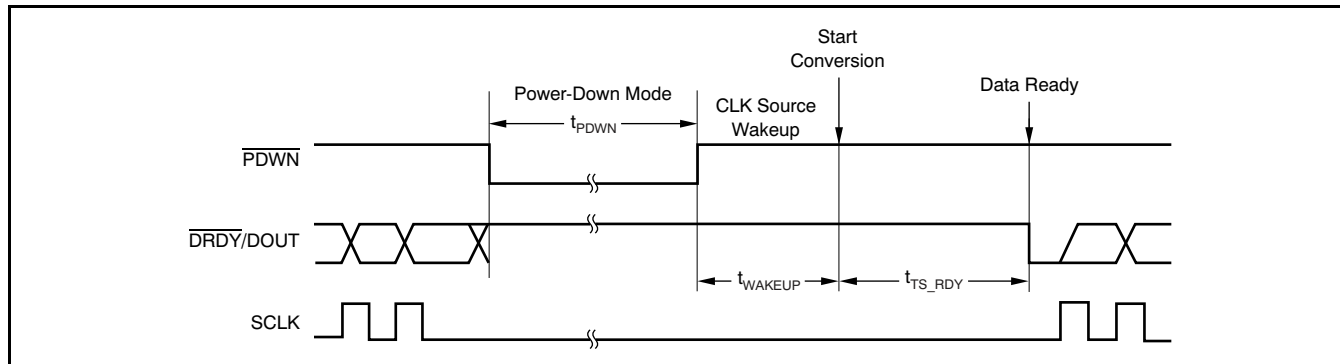

Figure 9. Wake-Up Timing from Power-Down Mode

SYMBOL	DESCRIPTION	MIN	TYP	UNITS
$t_{WAKEUP}^{(1)}$	Wake-up time after Power-Down mode		7.95	$\mu s$
$t_{PDWN}^{(1)}$	PDWN pulse width	26		$\mu s$

(1) Based on an ideal internal oscillator.

## APPLICATION EXAMPLE

### Weigh Scale System

Figure 10 shows a typical ADS1131 application as part of a weigh scale system.

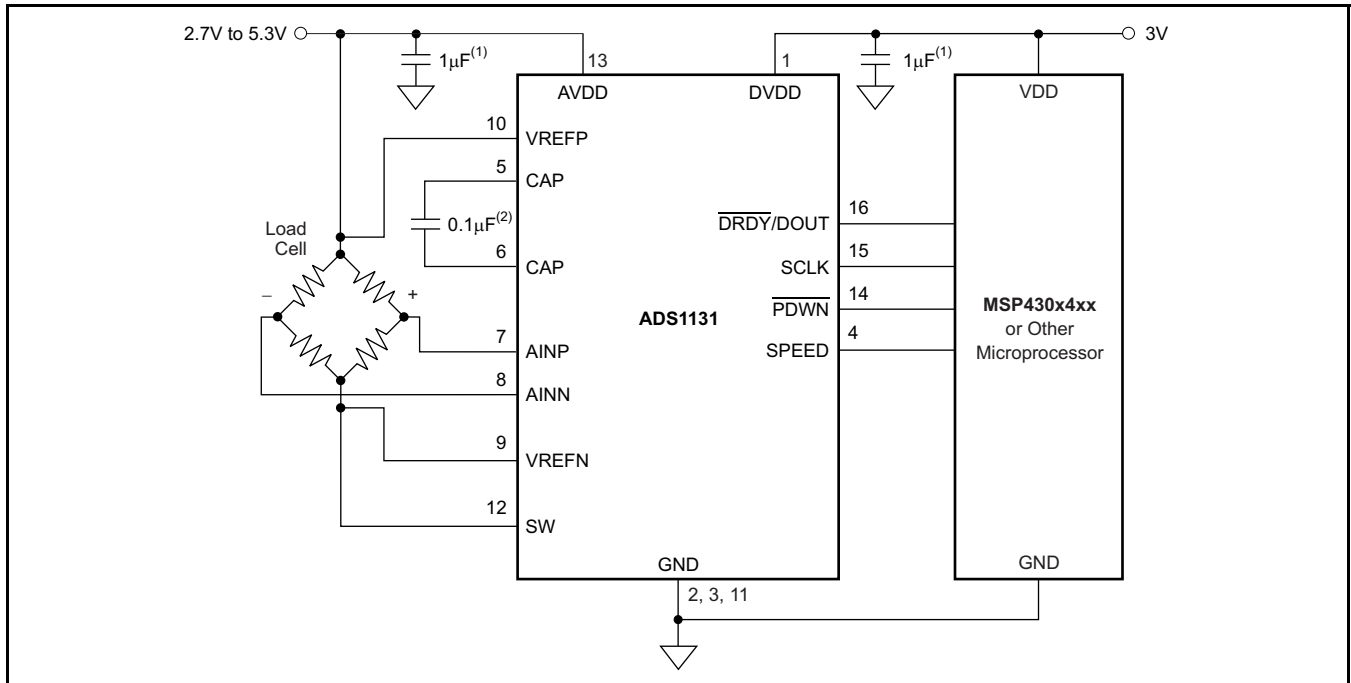

- (1) Place a  $0.1\mu\text{F}$  or higher capacitor as close as possible on both AVDD and DVDD.
- (2) Place capacitor very close to the ADS1131 CAP pins for optimal performance.

**Figure 10. Weigh Scale Example**

## REVISION HISTORY

NOTE: Page numbers for previous revisions may differ from page numbers in the current version.

<b>Changes from Revision B (September 2011) to Revision C</b>	<b>Page</b>
• Changed pin 12 name from PSW to SW in pinout drawing .....	5
• Changed pin 12 name from PSW to SW in Pin Descriptions table .....	5
• Changed pin numbers in <a href="#">Figure 10</a> to match the device pinout .....	13

<b>Changes from Revision A (May 2010) to Revision B</b>	<b>Page</b>
• Changed <i>Supply Range</i> Features bullet .....	1
• Deleted <i>ESD Ratings</i> row and footnote 2 from Absolute Maximum Ratings table .....	2
• Changed Digital Input/Output, $V_{IH}$ <i>Logic level</i> parameter minimum specification in Electrical Characteristics table .....	3
• Changed Power Supply, <i>Power-supply voltage</i> parameter minimum specification in Electrical Characteristics table .....	4
• Deleted Power Supply, <i>Analog supply current</i> parameter maximum specifications in Electrical Characteristics table .....	4
• Deleted Power Supply, <i>Digital supply current</i> parameter maximum specifications in Electrical Characteristics table .....	4
• Deleted Power Supply, <i>Power dissipation</i> parameter maximum specifications in Electrical Characteristics table .....	4
• Deleted minimum specification and added typical specification to $t_{UPDATE}$ row of table corresponding to <a href="#">Figure 6</a> .....	10
• Deleted <i>Power-Up Sequence</i> section .....	12

**PACKAGING INFORMATION**

Orderable Device	Status (1)	Package Type	Package Drawing	Pins	Package Qty	Eco Plan (2)	Lead finish/ Ball material (6)	MSL Peak Temp (3)	Op Temp (°C)	Device Marking (4/5)	Samples
ADS1131ID	ACTIVE	SOIC	D	16	40	RoHS & Green	NIPDAU	Level-2-260C-1 YEAR	-40 to 85	ADS1131	<a href="#">Samples</a>
ADS1131IDR	ACTIVE	SOIC	D	16	2500	RoHS & Green	NIPDAU	Level-2-260C-1 YEAR	-40 to 85	ADS1131	<a href="#">Samples</a>

(1) The marketing status values are defined as follows:

**ACTIVE:** Product device recommended for new designs.

**LIFEBUY:** TI has announced that the device will be discontinued, and a lifetime-buy period is in effect.

**NRND:** Not recommended for new designs. Device is in production to support existing customers, but TI does not recommend using this part in a new design.

**PREVIEW:** Device has been announced but is not in production. Samples may or may not be available.

**OBSOLETE:** TI has discontinued the production of the device.

(2) **RoHS:** TI defines "RoHS" to mean semiconductor products that are compliant with the current EU RoHS requirements for all 10 RoHS substances, including the requirement that RoHS substance do not exceed 0.1% by weight in homogeneous materials. Where designed to be soldered at high temperatures, "RoHS" products are suitable for use in specified lead-free processes. TI may reference these types of products as "Pb-Free".

**RoHS Exempt:** TI defines "RoHS Exempt" to mean products that contain lead but are compliant with EU RoHS pursuant to a specific EU RoHS exemption.

**Green:** TI defines "Green" to mean the content of Chlorine (Cl) and Bromine (Br) based flame retardants meet JS709B low halogen requirements of <=1000ppm threshold. Antimony trioxide based flame retardants must also meet the <=1000ppm threshold requirement.

(3) MSL, Peak Temp. - The Moisture Sensitivity Level rating according to the JEDEC industry standard classifications, and peak solder temperature.

(4) There may be additional marking, which relates to the logo, the lot trace code information, or the environmental category on the device.

(5) Multiple Device Markings will be inside parentheses. Only one Device Marking contained in parentheses and separated by a "~" will appear on a device. If a line is indented then it is a continuation of the previous line and the two combined represent the entire Device Marking for that device.

(6) Lead finish/Ball material - Orderable Devices may have multiple material finish options. Finish options are separated by a vertical ruled line. Lead finish/Ball material values may wrap to two lines if the finish value exceeds the maximum column width.

**Important Information and Disclaimer:**The information provided on this page represents TI's knowledge and belief as of the date that it is provided. TI bases its knowledge and belief on information provided by third parties, and makes no representation or warranty as to the accuracy of such information. Efforts are underway to better integrate information from third parties. TI has taken and continues to take reasonable steps to provide representative and accurate information but may not have conducted destructive testing or chemical analysis on incoming materials and chemicals. TI and TI suppliers consider certain information to be proprietary, and thus CAS numbers and other limited information may not be available for release.

In no event shall TI's liability arising out of such information exceed the total purchase price of the TI part(s) at issue in this document sold by TI to Customer on an annual basis.





**TAPE AND REEL INFORMATION**

**QUADRANT ASSIGNMENTS FOR PIN 1 ORIENTATION IN TAPE**

\*All dimensions are nominal

Device	Package Type	Package Drawing	Pins	SPQ	Reel Diameter (mm)	Reel Width W1 (mm)	A0 (mm)	B0 (mm)	K0 (mm)	P1 (mm)	W (mm)	Pin1 Quadrant
ADS1131IDR	SOIC	D	16	2500	330.0	16.4	6.5	10.3	2.1	8.0	16.0	Q1

**TAPE AND REEL BOX DIMENSIONS**

\*All dimensions are nominal

Device	Package Type	Package Drawing	Pins	SPQ	Length (mm)	Width (mm)	Height (mm)
ADS1131IDR	SOIC	D	16	2500	340.5	336.1	32.0

**TUBE**

\*All dimensions are nominal

Device	Package Name	Package Type	Pins	SPQ	L (mm)	W (mm)	T (μm)	B (mm)
ADS1131ID	D	SOIC	16	40	507	8	3940	4.32

D (R-PDSO-G16)

PLASTIC SMALL OUTLINE

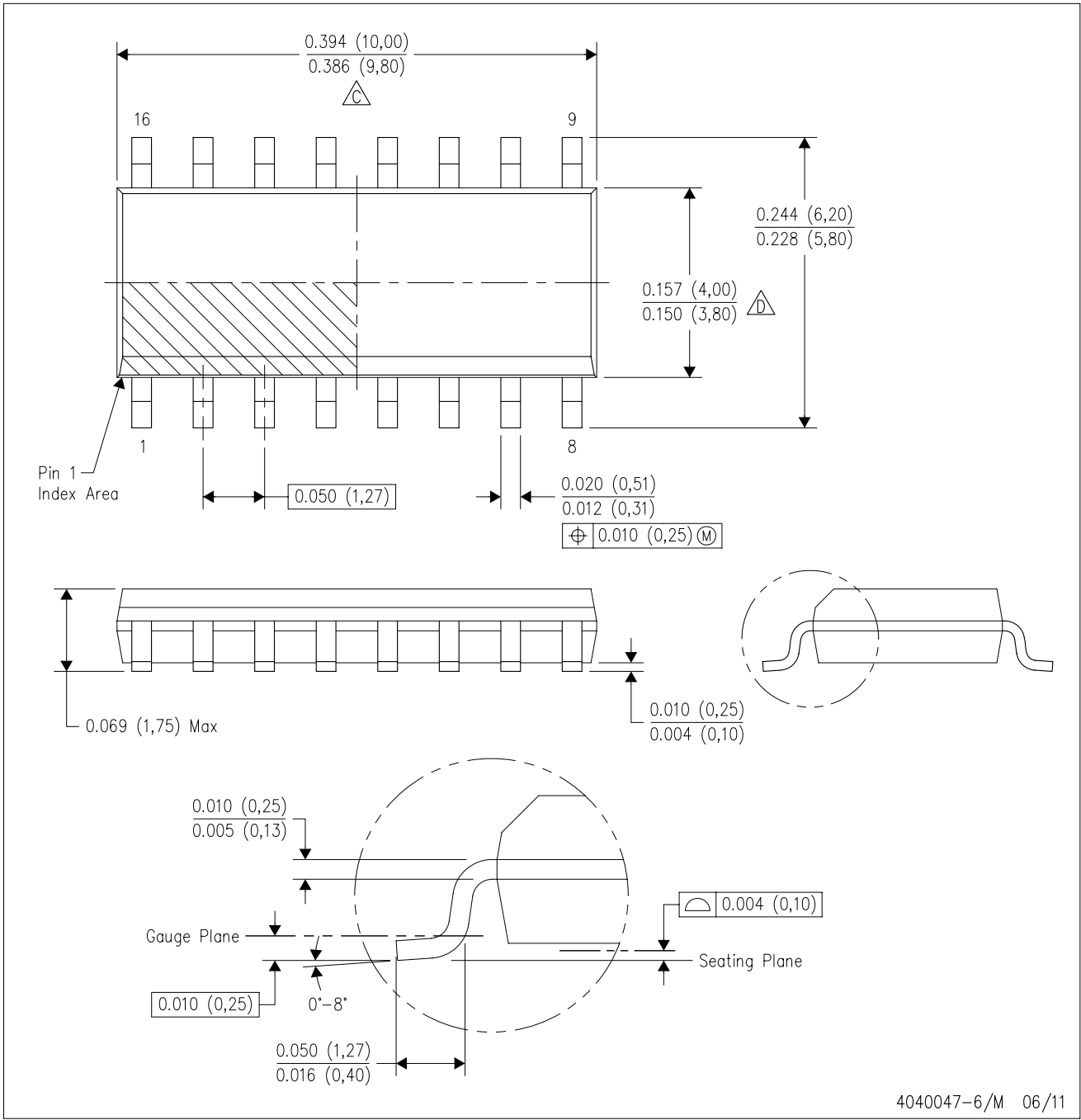

4040047-6/M 06/11

- NOTES:
- A. All linear dimensions are in inches (millimeters).
  - B. This drawing is subject to change without notice.
  - $\triangle$  Body length does not include mold flash, protrusions, or gate burrs. Mold flash, protrusions, or gate burrs shall not exceed 0.006 (0,15) each side.
  - $\triangle$  Body width does not include interlead flash. Interlead flash shall not exceed 0.017 (0,43) each side.
  - E. Reference JEDEC MS-012 variation AC.

D (R-PDSO-G16)

PLASTIC SMALL OUTLINE

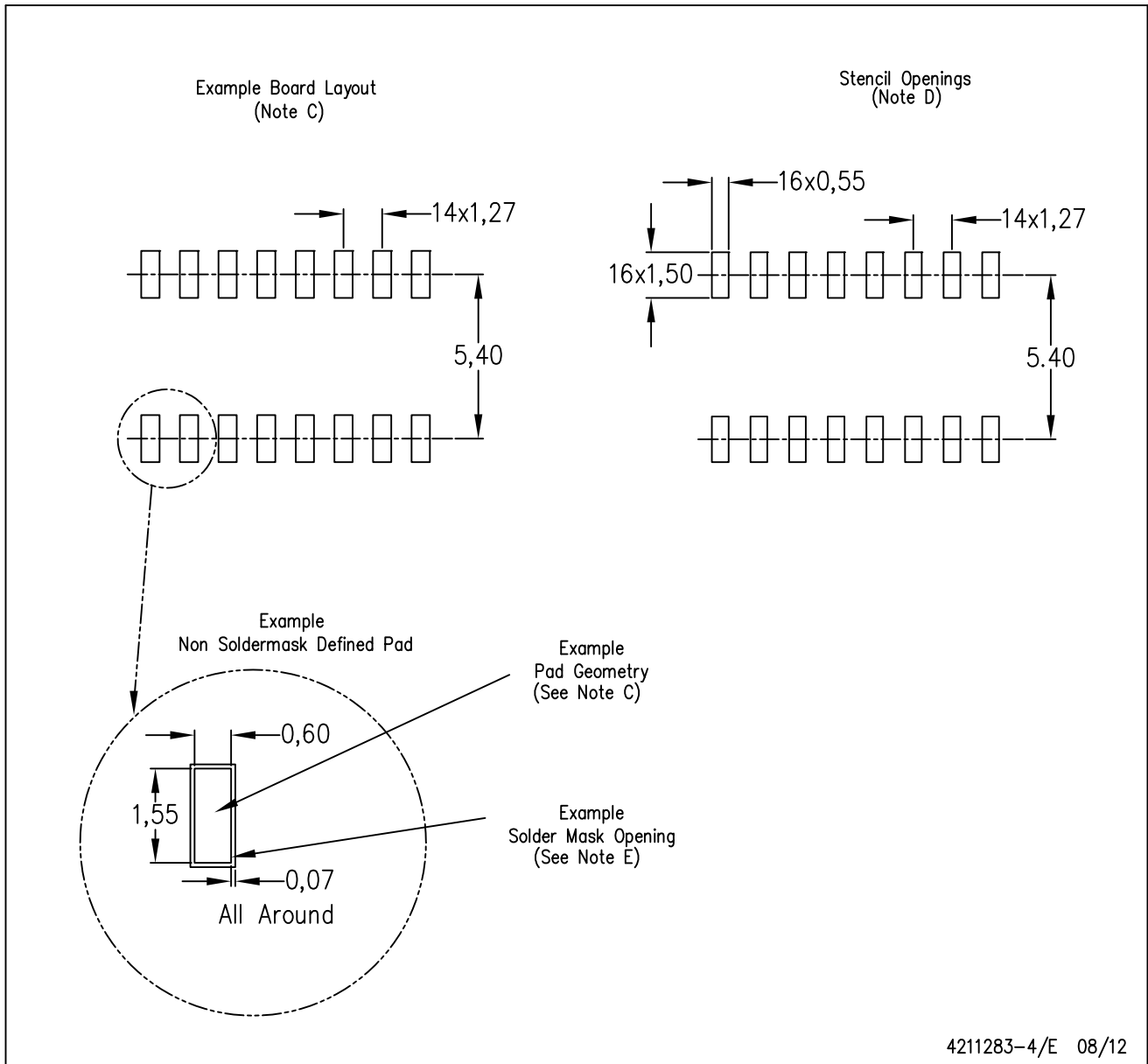

- NOTES:
- All linear dimensions are in millimeters.
  - This drawing is subject to change without notice.
  - Publication IPC-7351 is recommended for alternate designs.
  - Laser cutting apertures with trapezoidal walls and also rounding corners will offer better paste release. Customers should contact their board assembly site for stencil design recommendations. Refer to IPC-7525 for other stencil recommendations.
  - Customers should contact their board fabrication site for solder mask tolerances between and around signal pads.

## IMPORTANT NOTICE AND DISCLAIMER

TI PROVIDES TECHNICAL AND RELIABILITY DATA (INCLUDING DATA SHEETS), DESIGN RESOURCES (INCLUDING REFERENCE DESIGNS), APPLICATION OR OTHER DESIGN ADVICE, WEB TOOLS, SAFETY INFORMATION, AND OTHER RESOURCES "AS IS" AND WITH ALL FAULTS, AND DISCLAIMS ALL WARRANTIES, EXPRESS AND IMPLIED, INCLUDING WITHOUT LIMITATION ANY IMPLIED WARRANTIES OF MERCHANTABILITY, FITNESS FOR A PARTICULAR PURPOSE OR NON-INFRINGEMENT OF THIRD PARTY INTELLECTUAL PROPERTY RIGHTS.

These resources are intended for skilled developers designing with TI products. You are solely responsible for (1) selecting the appropriate TI products for your application, (2) designing, validating and testing your application, and (3) ensuring your application meets applicable standards, and any other safety, security, regulatory or other requirements.

These resources are subject to change without notice. TI grants you permission to use these resources only for development of an application that uses the TI products described in the resource. Other reproduction and display of these resources is prohibited. No license is granted to any other TI intellectual property right or to any third party intellectual property right. TI disclaims responsibility for, and you will fully indemnify TI and its representatives against, any claims, damages, costs, losses, and liabilities arising out of your use of these resources.

TI's products are provided subject to [TI's Terms of Sale](#) or other applicable terms available either on [ti.com](http://ti.com) or provided in conjunction with such TI products. TI's provision of these resources does not expand or otherwise alter TI's applicable warranties or warranty disclaimers for TI products.

TI objects to and rejects any additional or different terms you may have proposed.

Mailing Address: Texas Instruments, Post Office Box 655303, Dallas, Texas 75265  
Copyright © 2022, Texas Instruments Incorporated