

NOTES:

- MATERIALS AND FINISHES:
 BODY - BRASS, ALBALOY PLATING
 CONTACT - BRASS & PHOSPHOR BRONZE, GOLD PLATING
 INSULATOR - PTFE, NATURAL
- ELECTRICAL:
 A. IMPEDANCE: 50 OHM
 B. FREQUENCY RANGE: DC - 11 GHz
 C. VSWR: 1.2 MAX @ 6 GHz
 D. INSERTION LOSS: 0.25 dB MAX.@ 6 GHz
 E. DIELECTRIC WITHSTANDING VOLTAGE: 2000 VRMS, MIN.
- MECHANICAL:
 A. DURABILITY: 50 OHM, NOMINAL
 B. TEMPERATURE RANGE: -65°C TO +165°C
- CRIMPED FERRULE HEX. CRIMP SIZE: .128"
- CONTACT PIN CAN BE SOLDERED OR USE 4-WAY INDENT TOOL #47025
- THE ASSEMBLIES MUST TEST BY SUBMERGING IN WATER FOR 1 MINUTE AT 8 PSI WITH NO VISIBLE LEAKAGE (COMPLIANT WITH IP68).

THIRD ANGLE PROJ.

REVISIONS				
REV	DESCRIPTION	DATE	ECO	APPR
NC	INITIAL RELEASE	19-Nov-10	----	MZ
A	UPDATED INS. TO IMPROVE ELECTRICAL PERFORMANCE	07-May-15	50484	MZ

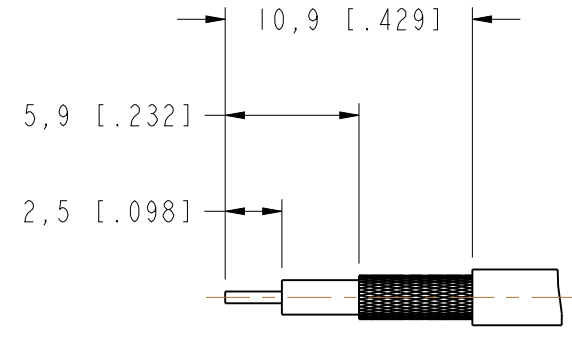
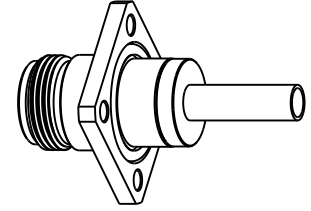

RECOMMENDED CABLE STRIPPING DIM'S

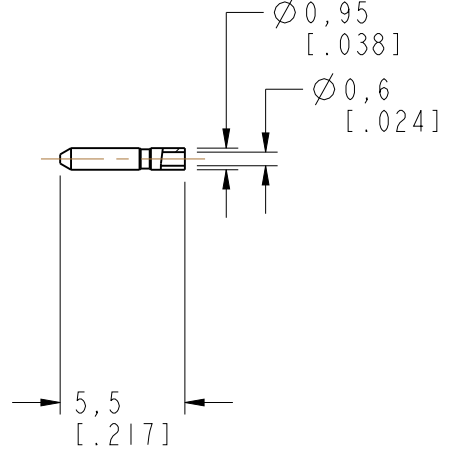
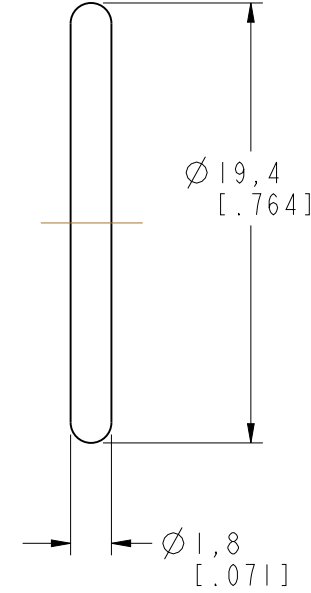
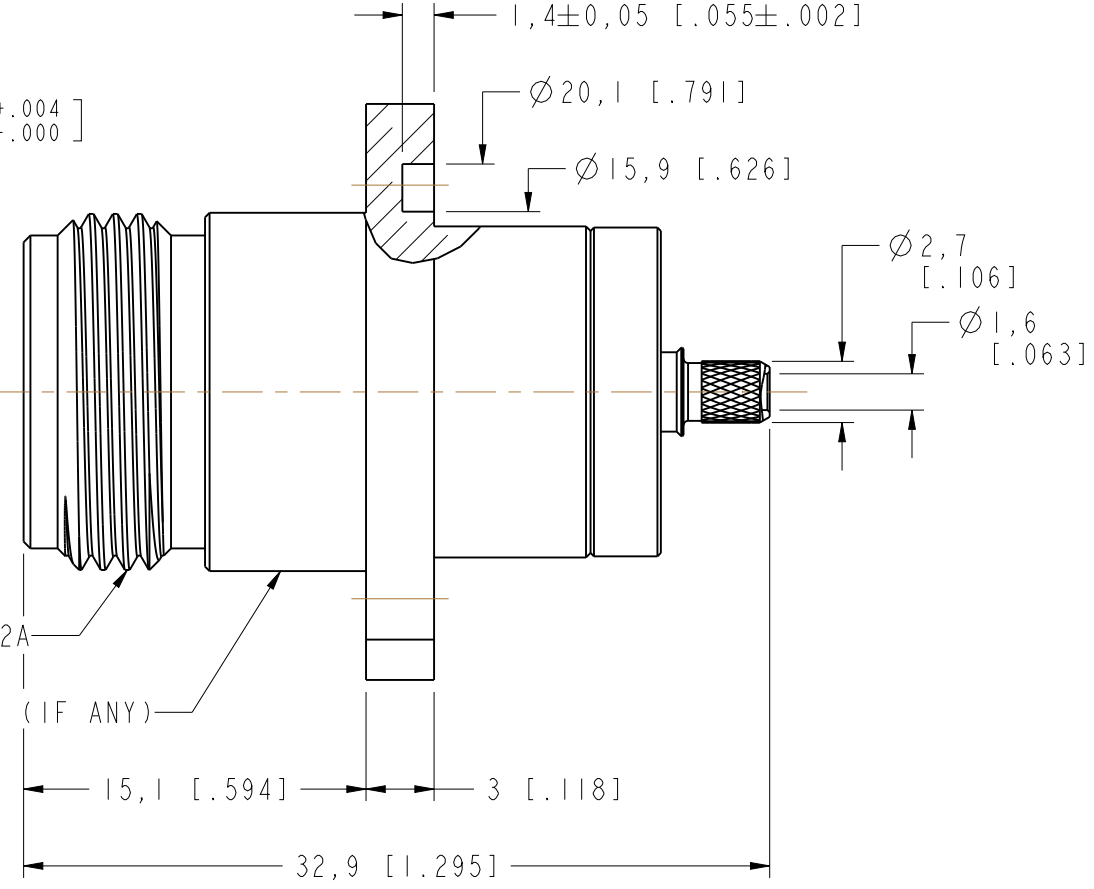
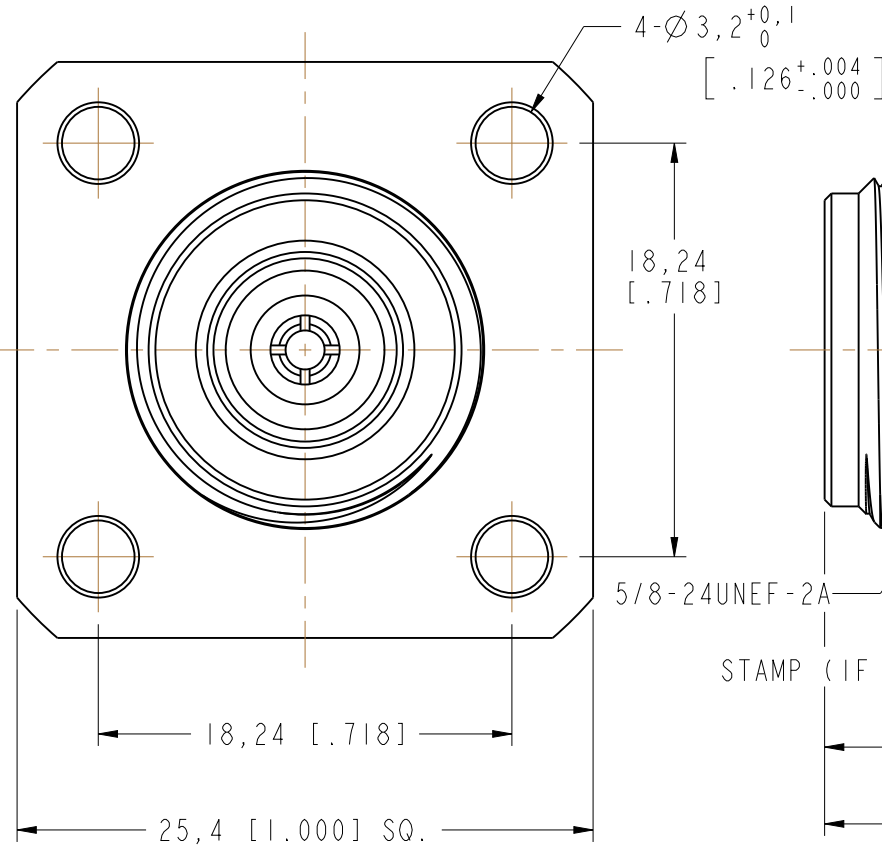
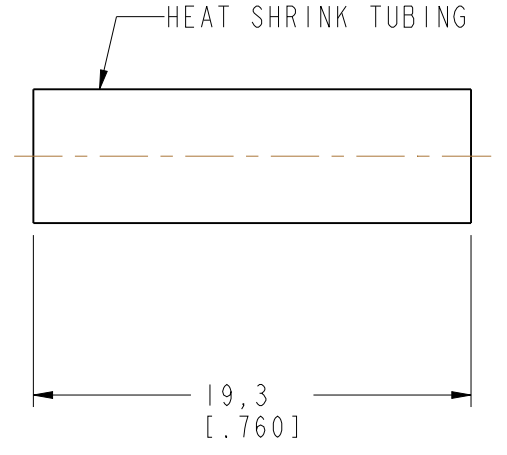
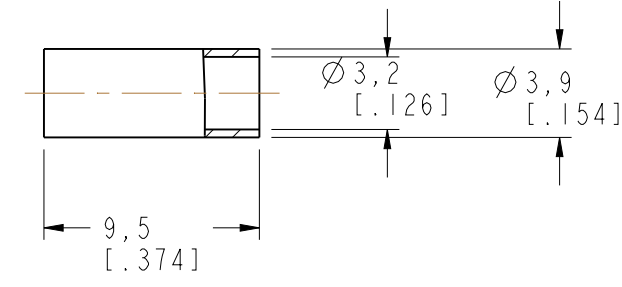

CUSTOMER OUTLINE DRAWING
 ALL OTHER SHEETS ARE FOR INTERNAL USE ONLY

UNLESS OTHERWISE SPECIFIED, DIMENSIONS ARE IN METRIC AND TOLERANCES ARE: <0.5mm ± 0.05mm 0.5 - 6mm ± 0.1mm 6 - 30mm ± 0.2mm 30 - 120mm ± 0.3mm ANGLES ± 1°	MATERIAL	DRAWN M.ZHANG	DATE 07-May-15	TITLE N PANEL RECEPT. JACK IP-68 COMPLIANT (FOR RG-316/U CABLE) SCALE: 3.0:1.0 SHEET 3 OF 3	Amphenol Connex
	NOTICE - These drawings, specifications, or other data (1) are, and remain the property of Amphenol corp. (2) must be returned upon request; and (3) are confidential and not to be disclosed to any person other than those to whom they are given by Amphenol Corp. the furnishing of these drawings, specifications, or other data by Amphenol Corp., or to any other person to anyone for any purpose is not to be regarded by implication or otherwise in any manner licensing, granting rights to permitting such holder or any other person to manufacture, use or sell any product, process or design, patented or otherwise, that may in any way be related to or disclosed by said drawings, specifications, or other data.	REFERENCE N6521G1-004-AT5GP-50 CONFIGURATION LEVEL: In Work	ENGINEER S.DUAN		
	FINISH	APPROVED S.HSIHE	DATE 07-May-15	DWG SIZE B	REV A
					ITEM NO. PART NO. 172173-14