

PART NUMBER	REV	FIRST USED
1385054-1	A	122500-1
1385054-2	A	565435-5
1385054-3	A	354500-1

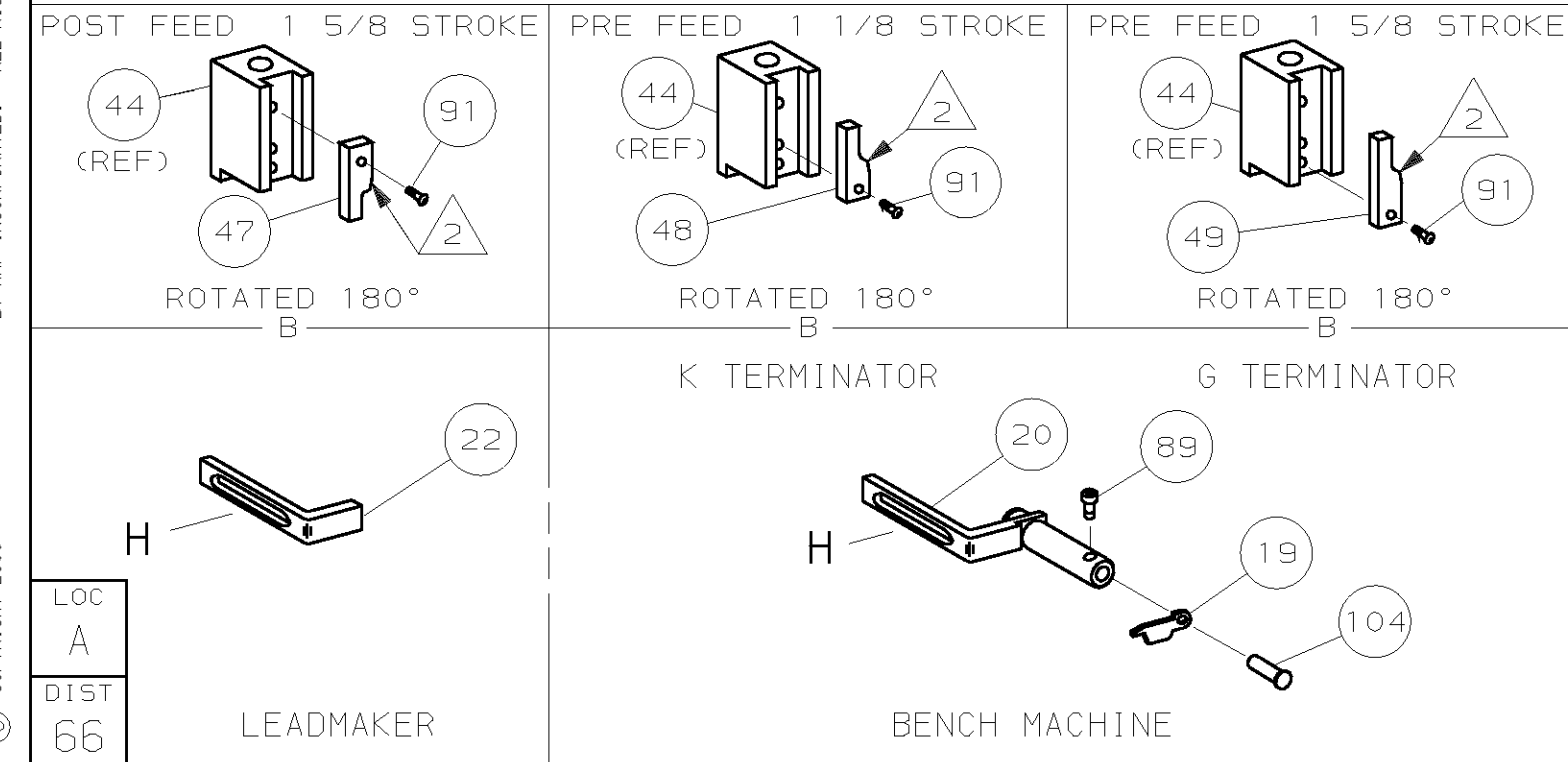
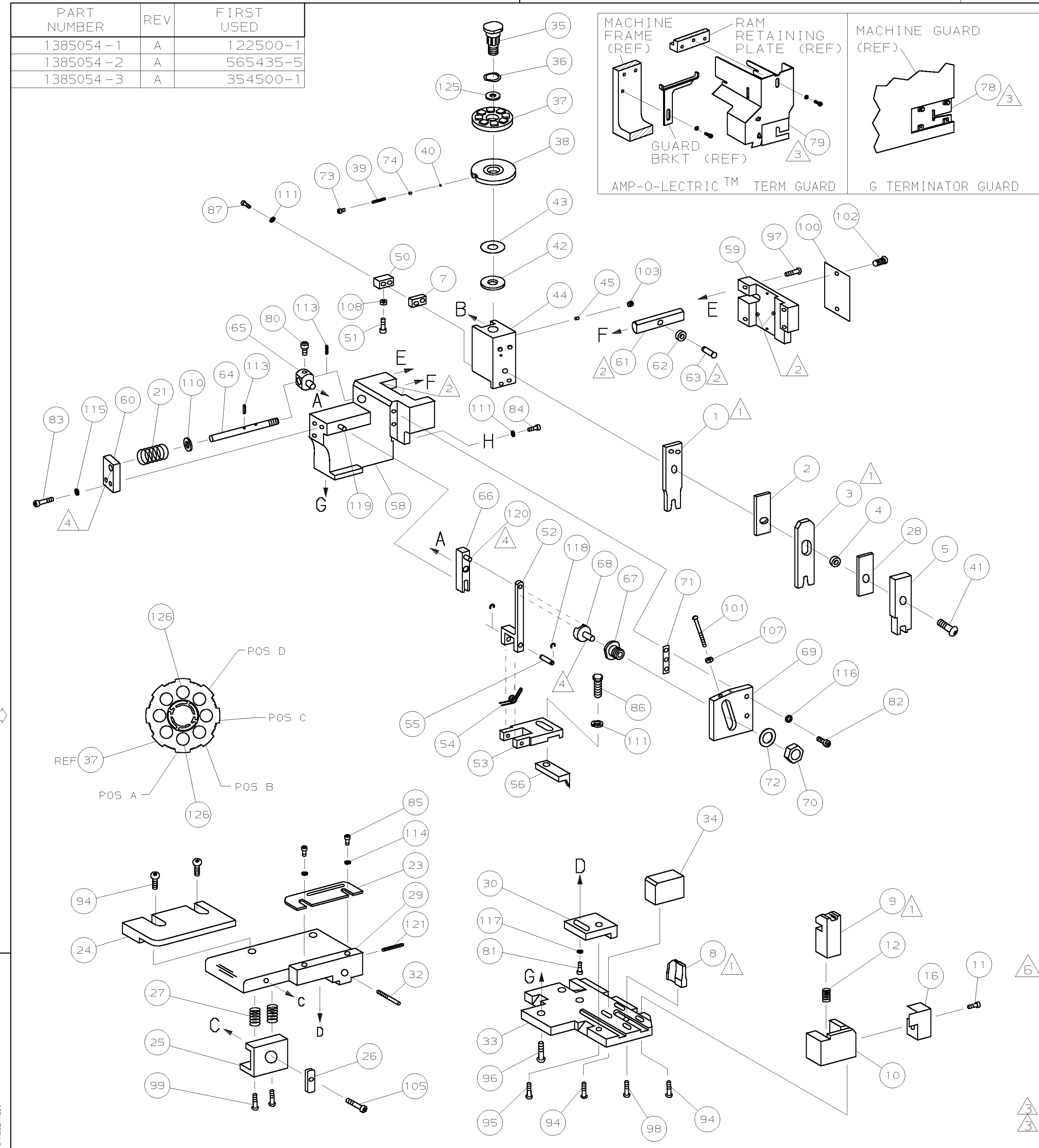

- 1 RECOMMENDED SPARE PARTS.
- 2 GREASE LIGHTLY.
- 3 GUARD MUST BE IN PLACE WHEN OPERATING APPLICATOR IN A BENCH MACHINE.
- 4 LUBRICATE DAILY USING NO. 20 MACHINE OIL.
- 5. ITEMS WITH QTY OF REF SPECIFIED (EXCEPT ITEMS 78 AND 79) ARE USED ON ITEM 46.
- 6 CUT TO LENGTH AT ASSEMBLY.

WIRE STRIP LENGTH		TERM APPL	SPEC	FEED	APPL INSTRUCTION	SET UP GAGE	LAYOUT
.188-.219			NONE	.530	408-8040	458637-1	L2384

CRIMP DATA (NON-AMP TERMINAL-CUST SPEC)			
PAD LTR	CRIMP HEIGHT	WIRE SIZE	
A	.049 ±.002 [1.24 ±0.05mm]	18	
B	NOT	USED	
C	NOT	USED	
D	NOT	USED	
CRIMP	SIZE	TYPE	RANGE
WIRE	.094 [2.39mm]	F	18
INSUL	.140 [3.56mm]	F	∅.090 REF

QTY	REF	REF	REF	U/M	DWG SIZE	PART NO	DESCRIPTION	ITEM NO
129								129
128								128
127								127
2	2	2	-	C		3-354779-0	PIN, WIRE DISC (.3140)A	126
1	1	1	-	A		986950-1	WASHER, FLAT PRECISION	125
1	1	1	-	A		217238-1	GENERAL INSTRUCTION PACKAGE	124
1	1	1	-	-		4088040	SF APPL INST 408-8040	123
122								122
1	1	1	-	A		4-21028-0	PIN, SLT SPR (∅.093x.75)ST GDE PL	121
REF	REF	REF	-	A		1-21030-1	PIN, DOWEL (∅.187x.50)LEVER	120
REF	REF	REF	-	A		1-21030-6	PIN, DOWEL (∅.187x1.25)HOUSING	119
REF	REF	REF	-	A		21045-3	RING, RET "C" (∅.187)FD FING PIN	118
1	1	1	-	A		21024-5	WASHER, LOCK (#10)ADJ BLK	117
REF	REF	REF	-	A		21024-5	WASHER, LOCK (#10)ADJ PLATE	116
REF	REF	REF	-	A		21024-5	WASHER, LOCK (#10)FEED GDE ROD	115
2	2	2	-	A		21024-2	WASHER, LOCK (#4)FRONT STP GUIDE	114
REF	REF	REF	-	A		5-21028-1	PIN, SLT SPR (∅.125x.50)ADJ ROD	113
112								112
4	4	4	-	A		21024-4	WASHER, LOCK (#8) STRIPPER	111
REF	REF	REF	-	A		21899-4	WASHER, FLAT (∅5/16) SCREW ADJ	110
109								109
1	1	1	-	A		21018-5	NUT, HEX (NO. 6)HOLDDOWN	108
REF	REF	REF	-	A		21068-5	NUT, HEX (6-32)FEED ADJ	107
106								106
1	1	1	-	A		22353-8	SCR, SHLD (∅.187x.25)DRAG LEVER	105
1	1	-	-	A		992031-1	PIN, CLEVIS	104
1	1	1	-	A		21009-2	SCR, SKT SET (1/4-20x.25 LW)RAM	103
2	2	2	-	A		21017-2	SCR, DRIVE (#2x.19)ID PLATE	102
REF	REF	REF	-	A		6-23715-5	SCR, PAN HD (6-32x1.50)FEED ADJ	101
100								100
1	1	1	-	B		461264-1	PLATE, IDENTIFICATION	100
2	2	2	-	A		3-21002-0	SCR, BHC (10-32x.88)DRAG	99
1	1	1	-	A		22733-8	SCR, BHC (8-32x.38 LW)ANVIL	98
REF	REF	REF	-	A		2-21002-9	SCR, BHC (10-32x.75)CAP	97
REF	REF	REF	-	A		2-22733-8	SCR, BHC (1/4-20x.62)HOUSING	96
REF	REF	REF	-	A		2-21002-7	SCR, BHC (10-32x.50)56 ADJ BLOCK	95
6	6	6	-	A		2-21002-2	SCR, BHC (8-32x.50)TERM H DWN	94
93								93
92								92
1	1	1	-	A		1-21002-7	SCR, BHC (6-32x.38)CAM	91
90								90
1	1	-	-	A		7-21000-9	SCR, SHC (4-40x.19)STRIPPER	89
88								88
2	2	2	-	A		2-21000-8	SCR, SHC (8-32x.59)DEP-HOLD	87
1	1	1	-	A		2-22603-0	SCR, HEX HD (8-32x.31)FEED FINGER	86
2	2	2	-	A		1-21000-3	SCR, SHC (4-40x.25)F ST GUIDE	85
1	1	1	-	A		2-21000-7	SCR, SHC (8-32x.50)STRIPPER	84
REF	REF	REF	-	A		3-21000-7	SCR, SHC (10-32x.75)FEED ROD GD	83
REF	REF	REF	-	A		3-21000-6	SCR, SHC (10-32x.62)FD ADJ BLK	82
1	1	1	-	A		3-21000-4	SCR, SHC (10-32x.38)56 ADJ BL	81
REF	REF	REF	-	A		3-21000-4	SCR, SHC (10-32x.38)PIVOT BLK	80
-	REF	-	-	B		455749-1	GUARD, WINDOW	79
REF	-	-	-	B		679532-1	INSERT, GUARD	78
77								77
76								76
75								75
1	1	1	-	A		690603-1	SPRING, ASSIST	74
1	1	1	-	A		23030-1	SCR, SHC (6-32x.25 SL)INS DISC	73
REF	REF	REF	-	A		458109-1	WASHER, SPECIAL	72
REF	REF	REF	-	A		690517-1	SPACER	71
71								71
70								70
69								69
68								68
67								67
66								66
65								65
64								64
63								63
62								62
61								61
60								60
59								59
58								58
57								57
56								56
55								55
54								54
53								53
52								52
51								51
50								50
49								49
48								48
47								47
46								46
45								45
44								44
43								43
42								42
41								41
40								40
39								39
38								38
37								37
36								36
35								35
34								34
33								33
32								32
31								31
30								30
29								29
28								28
27								27
26								26
25								25
24								24
23								23
22								22
21								21
20								20
19								19
18								18
17								17
16								16
15								15
14								14
13								13
12								12
11								11
10								10
9								9
8								8
7								7
6								6
5								5
4								4
3								3
2								2
1								1

QTY	REF	REF	REF	U/M	DWG SIZE	PART NO	DESCRIPTION	ITEM NO
1	1	1	-	B		690542-2	PAWL, FEED	56
REF	REF	REF	-	B		240624-1	PIN, FEED FINGER	55
REF	REF	REF	-	B		691499-1	SPRING, FEED FINGER	54
REF	REF	REF	-	B		690541-1	HOLDER, FEED FINGER	53
REF	REF	REF	-	A		455679-1	LEVER, TERMINAL FEED ARM	52
1	1	1	-	A		811242-2	BUMPER, HOLDDOWN	51
1	1	1	-	A		690753-1	SPACER, TONKER	50
1	-	-	-	B		690602-6	CAM, PRE-FEED 1 5/8 ST	49
-	1	-	-	B		690602-5	CAM, PRE-FEED 1 1/8 ST	48
-	-	1	-	B		690501-4	CAM, POST-FEED 1 5/8 ST	47
1	1	1	-	B		459456-1	APPLICATOR, BASIC (SUBASSY)	46
1	1	1	-	A		690191-1	PLUG, NYLON	45
1	1	1	-	C		819307-7	RAM	44
1	1	1	-	A		690125-1	WASHER, LAMINATED	43
1	1	1	-	A		690124-1	WASHER, RAM	42
1	1	1	-	A		7-21002-9	BOLT, CRIMPER (5/16x1.00)	41
1	1	1	-	A		23241-6	BALL, STEEL	40
1	1	1	-	A		690170-1	SPRING, COMPRESSION	39
1	1	1	-	C		690142-4	DISC, INSULATION	38
1	1	1	-	D		354777-1	WIRE DISC, PLASTIC	37
1	1	1	-	A		22480-5	WASHER, SPRING	36
1	1	1	-	B		690212-1	POST, RAM	3