



EV5920-5048-V-00A

60V, 15A, 7mΩ R_{DS(ON)}

Hot-Swap Intelli-Fuse Solution

DESCRIPTION

The EV5920-5048-V-00A is an evaluation board designed to demonstrate the capabilities of the MP5920 and the MP5048.

The MP5920 is a hot-swap protection controller that protects circuitry from transients on its input. It works with an Intelli-Fuse, which can be turned on or off via the ON pin and feeds back the current, voltage, and temperature information to the MP5920. The MP5920 limits the Intelli-Fuse's maximum load current by controlling the current limit reference voltage through CLPWM. The PMBus interface allows the MP5920 to read current, voltage, or temperature data and input power from a 12-bit analog-to-digital converter (ADC).

The MP5920 is available in a TQFN-32 (4mmx4mm) package.

The MP5048 is a monolithic, integrated controller and switch. It can operate as a standalone device, or be controlled by a hot-swap controller. The MP5048 is capable of driving up to 15A of continuous current per MP5048 device. The MP5048 simplifies system design by providing an integrated solution to monitor the output current and die temperature, eliminating the need for an external current-sense power resistor, power MOSFET, or thermal sense. The MP5048 detects the power FET gate, source, and drain short conditions, and provides feedback for the controller. It can also be paralleled for higher current applications.

The MP5048 is available in a QFN-30 (5mmx5mm) package.

ELECTRICAL SPECIFICATIONS

Parameter	Value	Units
Input voltage	48	V
Output voltage	48	V
Current limit per MP5048	15	A
Number of active MP5920 devices	1	-
Number of active MP5048 devices	5	-

FEATURES

- 24V to 60V Operating Input Range
- Maximum 15A Output Current per Phase
- Integrated 7mΩ Power FET
- Built-In MOSFET Driver
- Integrated Current Sense with Sense Output
- Separate Current-Sense Output Used to Configure the Over-Current Value
- Built-In Soft Start and Insertion Delay
- Output Short-Circuit Protection (SCP), Over-Temperature Protection (OTP), and Built-In Fuse Health Diagnostics
- Fault Signal Output
- Parallel Operation for Higher Current Applications
- Integrated Intelli-Fuse Temperature Sense
- Controllable Intelli-Fuse On/Off
- PMBus Fast Mode Compliant
- Built-In 12-Bit ADC for Current, V_{IN}, V_{OUT}, or Temperature Reading
- Programmable Current Limit Reference Voltage for Intelli-Fuse Current Limit Set
- Parameters Configurable via the PMBus
- Reports Power and Energy Consumption

APPLICATIONS

- Hot-Swap Applications
- PC Cards
- Disk Drives
- Servers
- Networking
- Laptops

All MPS parts are lead-free, halogen-free, and adhere to the RoHS directive. For MPS green status, please visit the MPS website under Quality Assurance. "MPS", the MPS logo, and "Simple, Easy Solutions" are registered trademarks of Monolithic Power Systems, Inc. or its subsidiaries.

EV5920-5048-V-00A EVALUATION BOARD

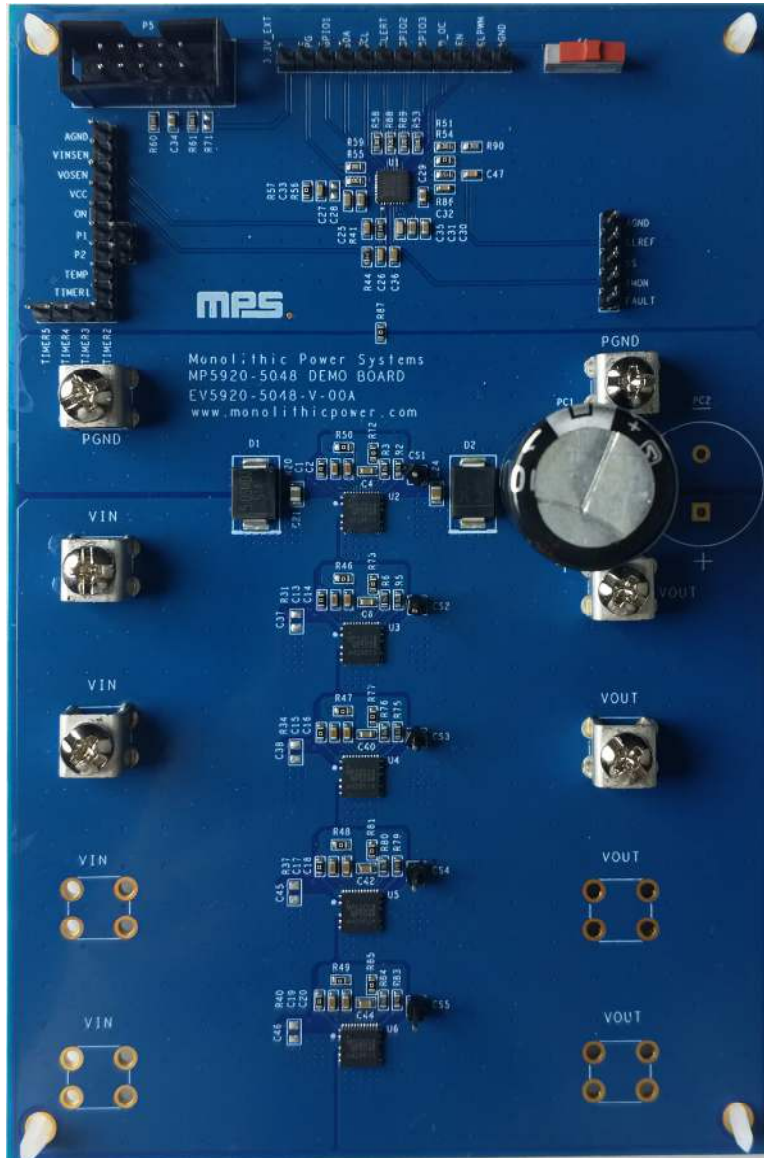

(LxWxH) 10cmx15cmx1.3cm

Board Number	MPS IC Numbers
EV5920-5048-V-00A	MP5920GRT-0000, MP5048GU

QUICK START GUIDE

1. Attach the load terminals to:
 - a. Positive (+): VOUT
 - b. Negative (-): GND
2. Preset the power supply output to 48V, then turn off the power supply.
3. Attach the power supply terminals to:
 - a. Positive (+): VIN
 - b. Negative (-): GND
4. Ensure that the EN switch (S1) is on; this switch turns on the MP5920.
5. Turn on the VIN power supply. The board should start up automatically.

EV5920-5048-V00A DEFAULT SETTINGS

Parameter	Value	Unit	Notes
VIN OVP limit	58.185	V	VIN_OV_FAULT_LIMIT (55h)
VIN On threshold	39.21	V	VIN_ON (35h)
VIN Off threshold	37.15	V	VIN_OFF (36h)
PG On threshold	35.94	V	POWER_GOOD_ON (5Eh)
PG Off threshold	27.72	V	POWER_GOOD_OFF (5Fh)
OCP total limit	96.41	A	IOUT_OC_FAULT_LIMIT(46h)
OCP limit (per MP5048)	17.2	A	R _{CS} and R _{CLREF}
OC warning limit	88.987	A	IIN_OC_WARN_LIMIT (5Dh)
Soft-start time	24	ms	C _{SS}
OTP limit	120	°C	OT_FAULT_LIMIT (4Fh)
OT warning limit	110	°C	OT_WARN_LIMIT (51h)

PROGRAMMING USER GUIDE

1. Use the PMBus interface kit (EVKT-USBI2C-02) to connect the EV5920-5048-V-00A to a PC (see Figure 1).

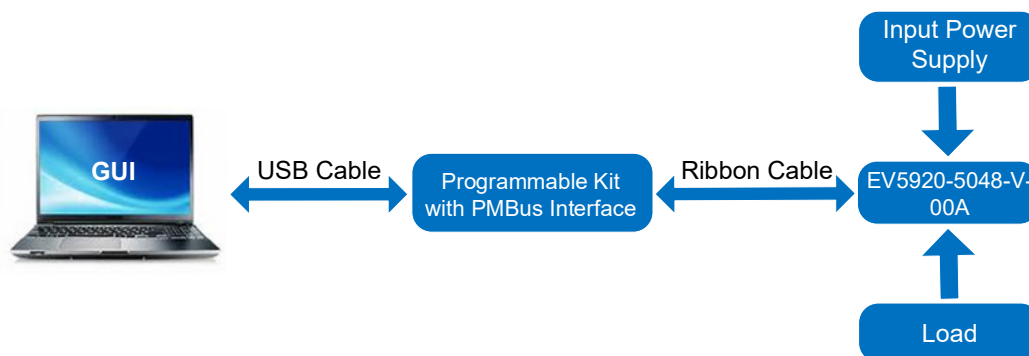
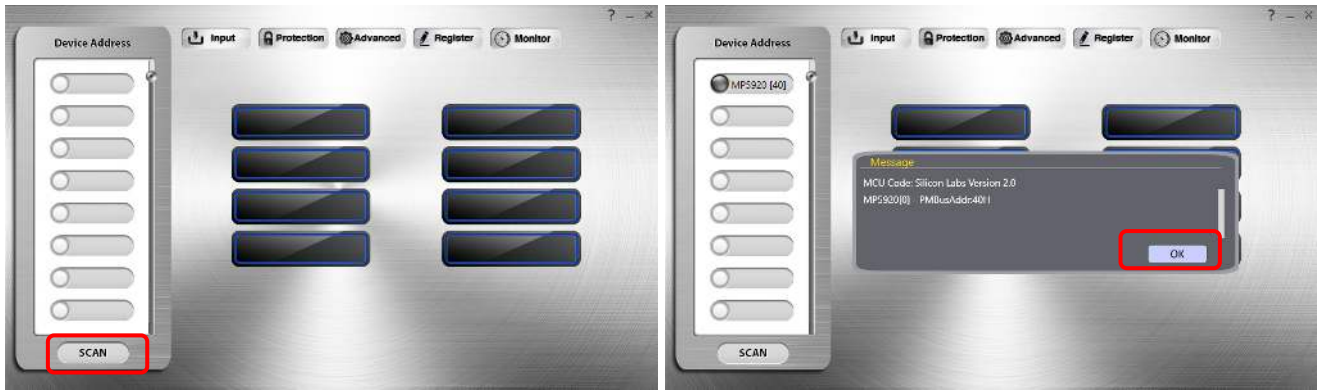
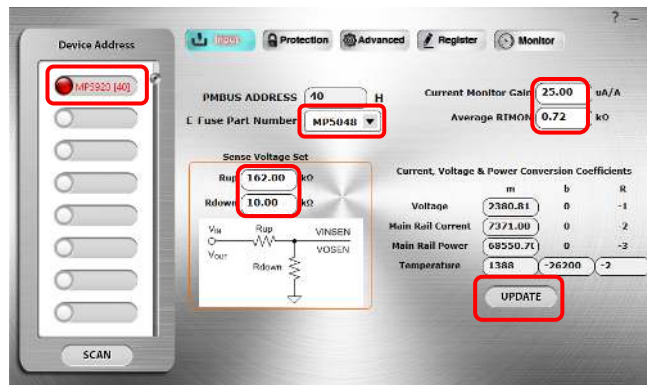

Figure 1: PMBus Connection Diagram

2. Turn on the power supply.
3. Open the GUI, then click the “Scan” button (see Figure 2). The devices should be listed in the left column.

Figure 2: MP5920 Scan Operation

4. Select the device labeled “MP5920 [40]”.
5. Update the parameters in the “Input” page following the sequence below:
 - a. E-Fuse Part Number: Select “MP5048.”
 - b. Sense Voltage Set: Set R_{UP} to 162kΩ and R_{DOWN} to 10kΩ.
 - c. Current Monitor Gain: Set to 25μA/A.
 - d. Average R_{MON}: Depending on the average resistor for the IMON pin, set to 0.72kΩ (3.6kΩ / 5 phases in parallel).
 - e. Click “Update.”

Figure 3: GUI Input Page

6. At this point, the system’s operation status can be monitored via the “Monitor” page (see Figure 4)

Figure 4: GUI Monitor Page

7. Use the “Protection” page configures the protection parameters, include the over-voltage (OV), over-current (OC), over-power (OP), over-temperature (OT), power good (PG) threshold, and packet error checking (PEC) mode settings.

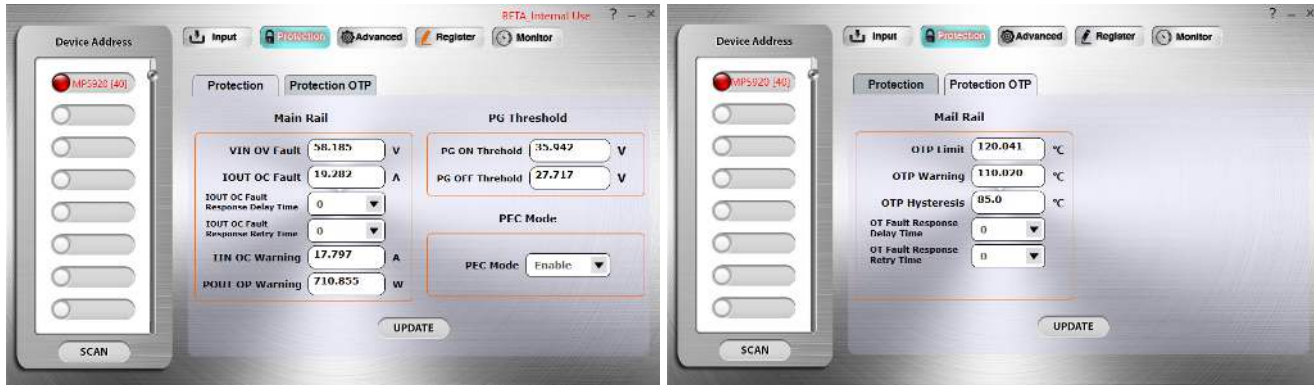

Figure 5: GUI Protection Page

8. Some advanced functions can be configured in the “Advanced” page.
- Basic Configuration:** Set the VIN on/off threshold, t_{ON} delay time, sample average time, and address selection (see Figure 6).

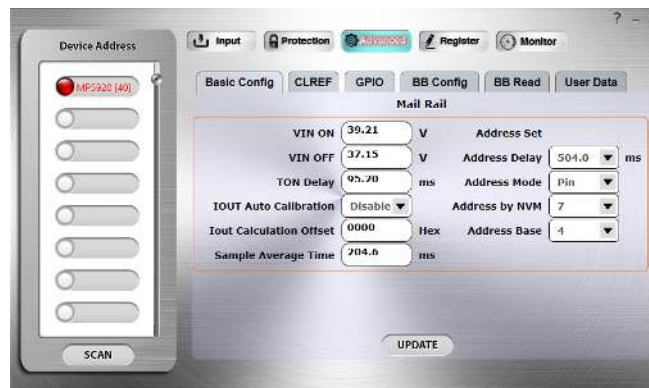

Figure 6: GUI Advanced Page, Basic Configuration Tab

- CLREF:** To use the MP5920 to provide the CLREF voltage, remove all MP5048 CLREF resistors, including R1, R4, R74, R78, and R82.
- GPIO:** GPIO can be configured to indicate a programmed fault or alert to the system.



Figure 7: GUI Advanced Page, GPIO Tab

- d. BB Configuration/BB Read/User Data: For details on configuring these functions, refer to the MP5920 datasheet.
9. The register list menu allows the user to import, export, and diagnose possible issues with the configuration file. Once the device is selected from the device list, all of the device registers in the register map are read and listed in the table (in hexadecimal format). The user also can enter the register's read/write interface by clicking "ALT" + "W".

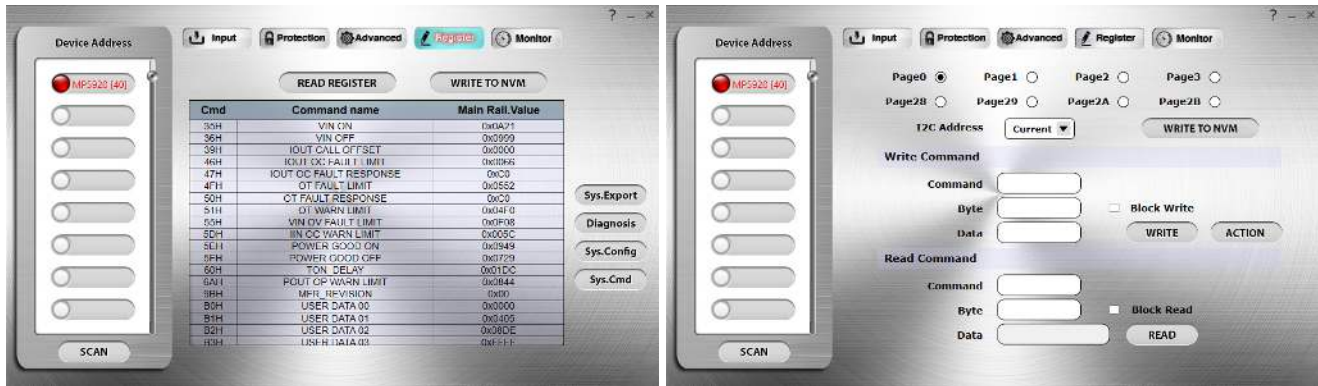

Figure 8: GUI Register Page

MP5048 PHASE NUMBER CONFIGURATION

The EV5920-5048-V-00A can be configured from 1-phase to 5-phase operation by adjusting parameters on the evaluation board (see Table 1).

Table 1: MP5048 Phase Number Configuration

	Active Part	Remove Resistors				Other	
			U3	U4	U5		U6
1-phase	U2	ON	R46	R47	R48	R49	-
		CLREF	R62	R74	R78	R82	
		SS	R73	R77	R81	R85	
		IMON	R6	R76	R80	R84	
		VDD3	R65	R66	R67	R68	
		FAULT	R21	R23	R25	R27	
		TEMP	R22	R24	R26	R28	
		MODE	R31	R34	R37	R40	
2-phase	U2, U3		U3	U4	U5	U6	TIMER: Connect TIMER1 and TIMER2 together.
		ON	-	R47	R48	R49	
		CLREF	-	R74	R78	R82	
		SS	-	R77	R81	R85	
		IMON	-	R76	R80	R84	
		VDD3	-	R66	R67	R68	
		FAULT	-	R23	R25	R27	
		TEMP	-	R24	R26	R28	
MODE	-	R34	R37	R40			
3-phase	U2, U3, U4		U3	U4	U5	U6	TIMER: Connect TIMER1 through TIMER3 together.
		ON	-	-	R48	R49	
		CLREF	-	-	R78	R82	
		SS	-	-	R81	R85	
		IMON	-	-	R80	R84	
		VDD3	-	-	R67	R68	
		FAULT	-	-	R25	R27	
		TEMP	-	-	R26	R28	
MODE	-	-	R37	R40			
4-phase	U2, U3, U4, U5		U3	U4	U5	U6	TIMER: Connect TIMER1 through TIMER4 together.
		ON	-	-	-	R49	
		CLREF	-	-	-	R82	
		SS	-	-	-	R85	
		IMON	-	-	-	R84	
		VDD3	-	-	-	R68	
		FAULT	-	-	-	R27	
		TEMP	-	-	-	R28	
MODE	-	-	-	R40			
5-phase	U2, U3, U4, U5, U6	The default configuration is 5-phase.				TIMER: Connect TIMER1 through TIMER5 together.	

EVALUATION BOARD SCHEMATIC

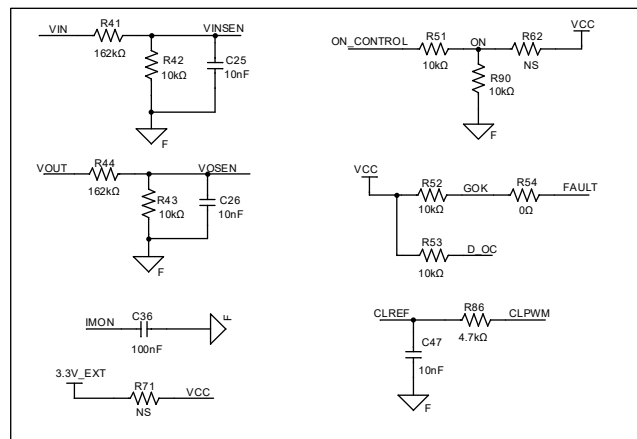
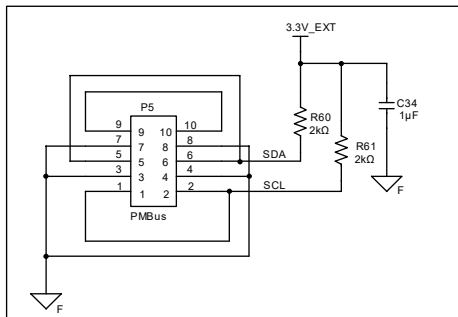
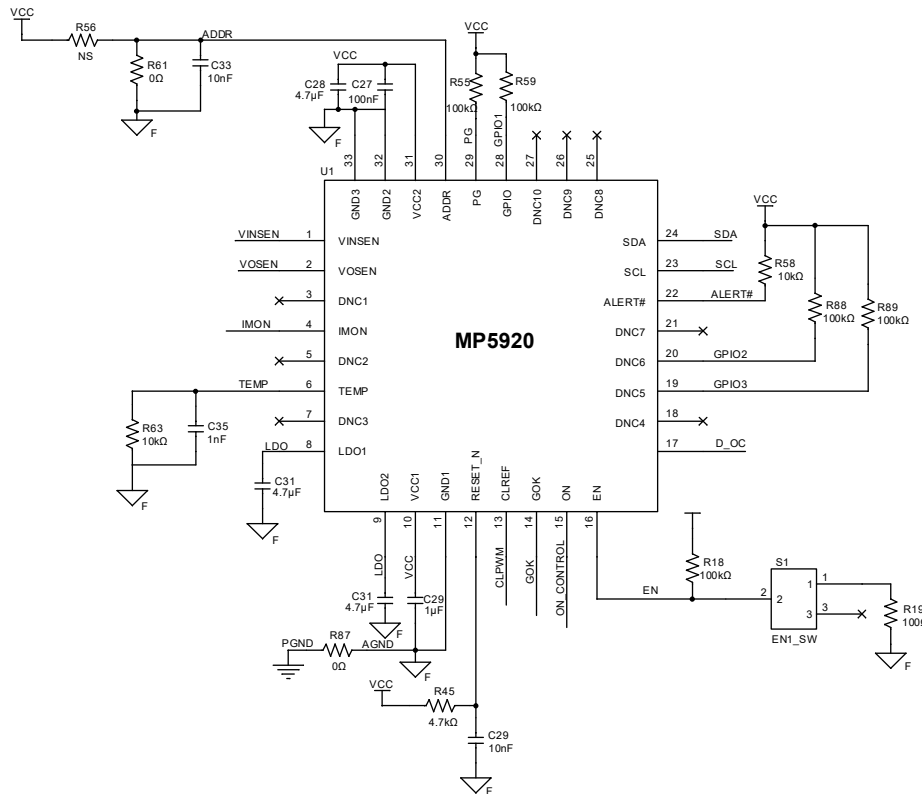

Figure 9: Evaluation Board Schematic (MP5920 Portion)

EVALUATION BOARD SCHEMATIC (continued)

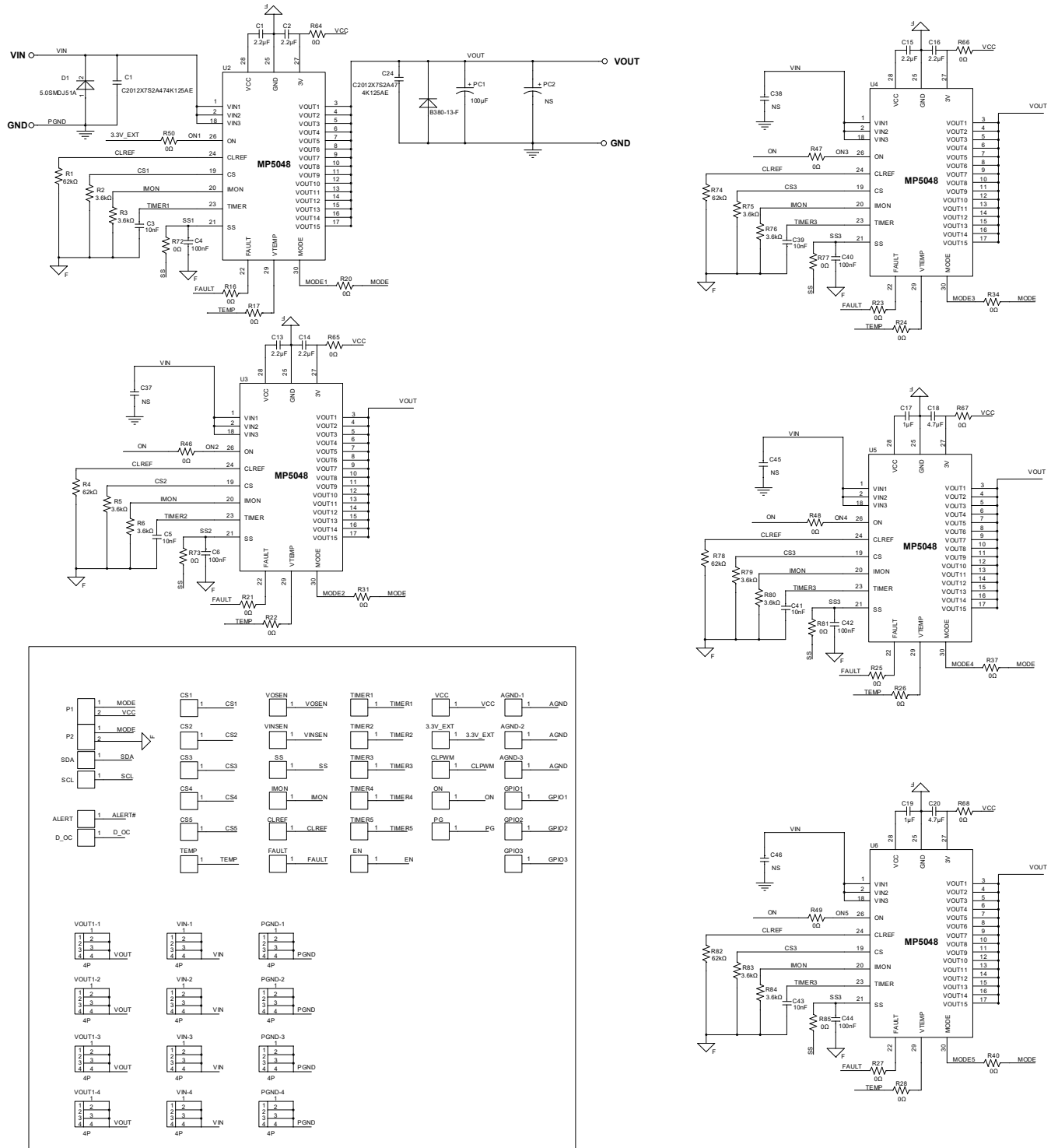

Figure 10: Evaluation Board Schematic (MP5048 Portion)

EV5920-5048-V-00A BILL OF MATERIALS

Qty	Designator	Value	Description	Package	Manufacturer	Manufacturer PN
33	TIMER1, GPIO1, CS1, AGND-1, TIMER2, GPIO2, CS2, AGND-2, TIMER3, GPIO3, CS3, AGND-3, TIMER4, CS4, TIMER5, CS5, 3.3V_EXT, VOSEN, VINSÉN, VCC, TEMP, SS, SDA, SCL, PG, ON, IMON, FAULT, EN, D_OC, CLREF, CLPWM, ALERT	3A	Test point	CONN/TP	Any	
10	C1, C2, C13, C14, C15, C16, C17, C18, C19, C20	2.2μF	Ceramic capacitor, 10V, X7R	0603	Murata	GRM188R71A225KE15D
2	C29, C34	1μF	Ceramic capacitor, 10V, X7R	0603	Murata	GRM188R71A105KA61D
3	C28, C30, C31	4.7μF	Ceramic capacitor, 10V, X5R	0603	Murata	GRM188R61A475KE15D
7	C4, C6, C27, C36, C40, C42, C44	100nF	Ceramic capacitor, 50V, X7R	0603	Murata	GRM188R71H104KA93D
2	C21, C24	470nF	Ceramic capacitor, 100V, X7R	0805	Murata	GRM21BR72A474KA73L
10	C3, C5, C25, C26, C32, C33, C39, C41, C43, C47	10nF	Ceramic capacitor, 50V, X7R	0603	Murata	GRM188R71H103KA01D
1	C35	1nF	Ceramic capacitor, 50V, X7R	0603	Murata	GRM188R71H102KA01D
12	C37, C38, C45, C46, R56, R62, R71, PC2, VIN-3, VIN-4, VOUT1-3, VOUT1-4	NS				
1	D1	51V	TVS diode	SMD	Littelfuse	5.0SMDJ51A
1	D2	3A	Schottky diode, 80V	SMC	Diodes, Inc.	B380-13-F
1	PC1	1000μF	Electrolytic capacitor, 100V	DIP	Panasonic	ECA-2AHG102
9	VIN-1, PGND-1, VIN-2, PGND-2, VIN-4, VOUT1-1, VOUT1-2, VOUT1-3, VOUT1-4	15A	Connector	DIP	Keystone	7701
2	P1, P2	TP	Test point	CONN/TP	Any	
1	P5	5 pins	Header, dual-row connector	2mmx5mm	Any	
5	R1, R4, R74, R78, R82	82kΩ	Film resistor, 1%	0603	Yageo	RC0603FR-0762KL
10	R2, R3, R5, R6, R75, R76, R79, R80, R83, R84	4.99kΩ	Film resistor, 1%	0603	Yageo	RC0603FR-0753K6L

EV5920-5048-V-00A BILL OF MATERIALS (continued)

Qty	Designator	Value	Description	Package	Manufacturer	Manufacturer PN
34	R16, R17, R20, R21, R22, R23, R24, R25, R26, R27, R28, R31, R34, R37, R40, R46, R47, R48, R49, R50, R54, R57, R64, R65, R66, R67, R68, R72, R73, R77, R81, R85, R87	0Ω	Film resistor, 1%	0603	Yageo	RC0603FR-070RL
5	R18, R55, R59, R88, R89	100kΩ	Film resistor, 1%	0603	Yageo	RC0603FR-07100KL
1	R19	100Ω	Film resistor, 1%	0603	Yageo	RC0603FR-07100RL
2	R41, R44	162kΩ	Film resistor, 1%	0603	Yageo	RC0603FR-07162KL
8	R42, R43, R51, R52, R53, R58, R63, R90	10kΩ	Film resistor, 1%	0603	Yageo	RC0603FR-0710KL
2	R45, R86	4.7kΩ	Film resistor, 1%	0603	Yageo	RC0603FR-074K7L
2	R60, R61	2kΩ	Film resistor, 1%	0603	Yageo	RC0603FR-072KL
1	S1	500mA	Switch	DIP	Wurth	450301014042
1	U1	MP5920	Hot-swap controller and energy monitor with PMBus interface	TQFN-32 (4mmx4mm)	MPS	MP5920GRT-0000
5	U2, U3, U4, U5, U6	MP5048	60V, 15A, 7mΩ R _{DS(ON)} hot-swap Intelli-Fuse solution	QFN-30 (5mmx5mm)	MPS	MP5048GU

PCB LAYOUT

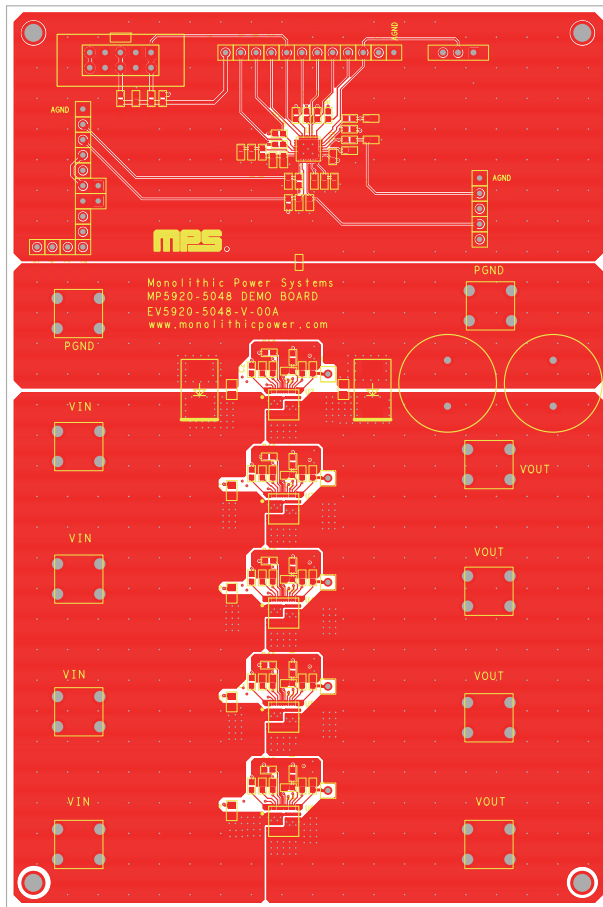

Figure 11: Top Layer

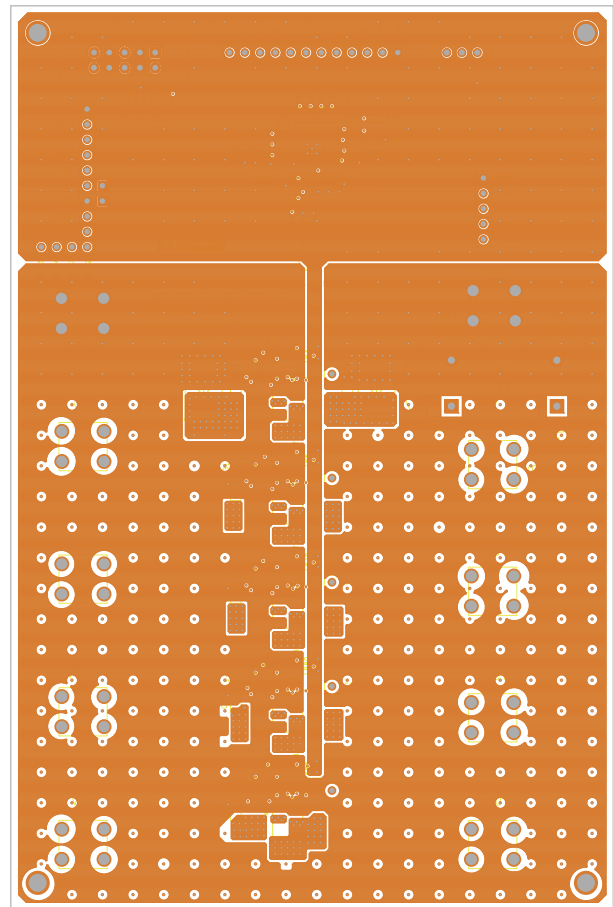

Figure 12: Mid-Layer 1

PCB LAYOUT (continued)

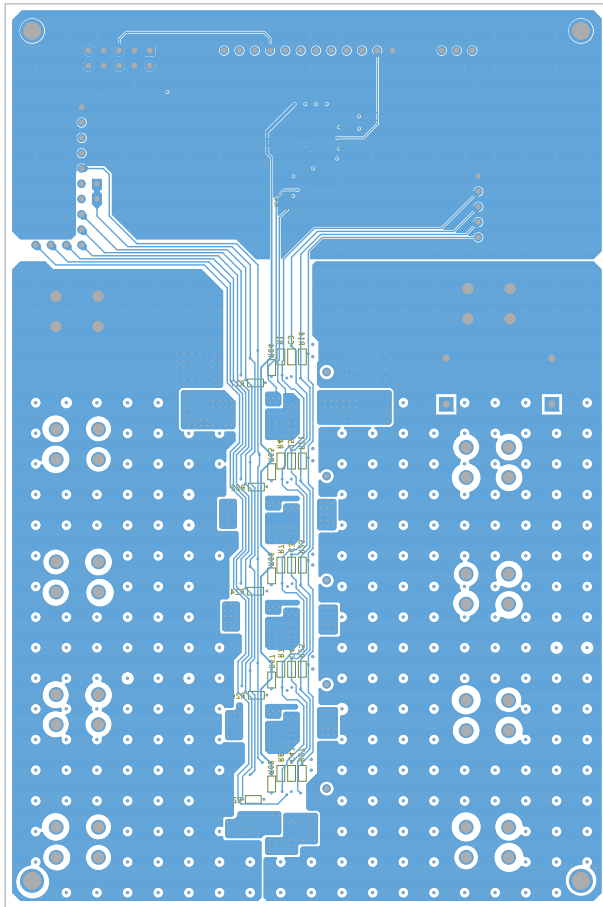

Figure 13: Mid-Layer 2

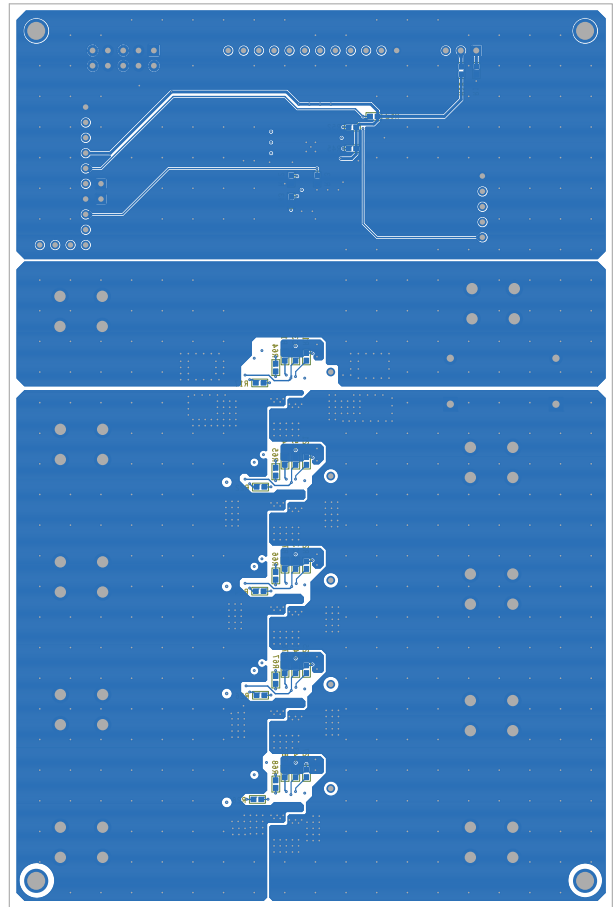

Figure 14: Bottom Layer



REVISION HISTORY

Revision #	Revision Date	Description	Pages Updated
1.0	5/14/2021	Initial Release	-

Notice: The information in this document is subject to change without notice. Please contact MPS for current specifications. Users should warrant and guarantee that third-party Intellectual Property rights are not infringed upon when integrating MPS products into any application. MPS will not assume any legal responsibility for any said applications.