

P	LTR	DESCRIPTION	DATE	DWN	APVD
	A	INITIAL RELEASE	12APR2021	BS	CB

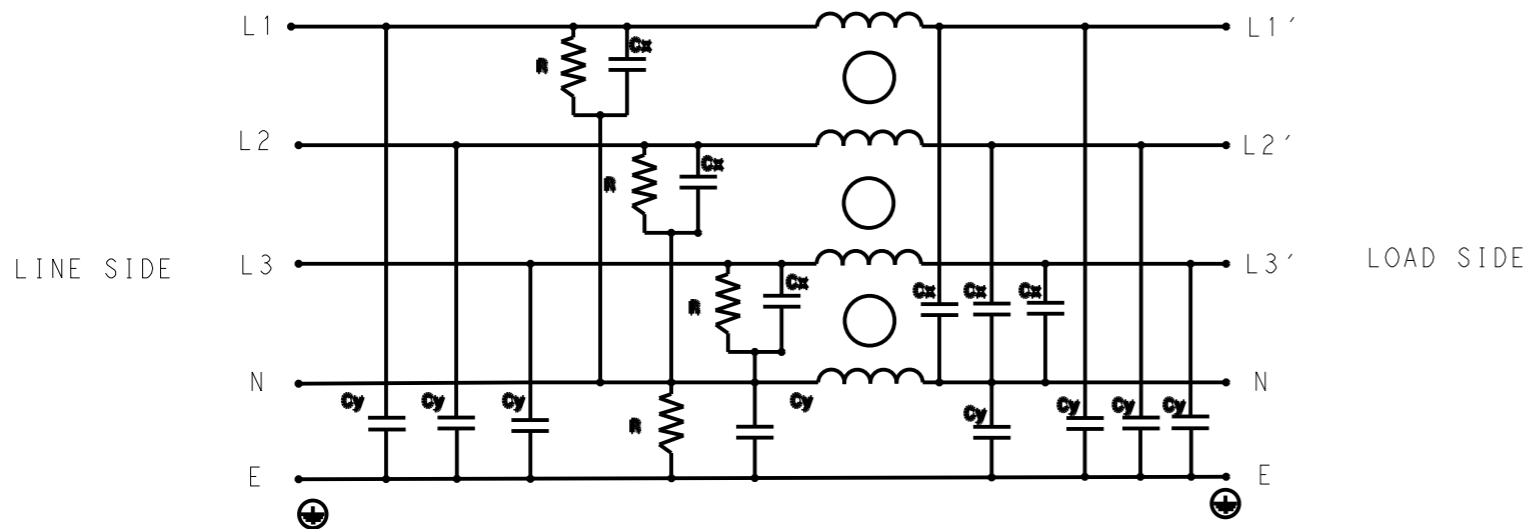

SCHEMATIC

SAFETY ORGANIZATIONS

THIS FILTER WILL BE FORMALLY RECOGNIZED, CERTIFIED OR APPROVED BY THE LISTED AGENCY. THEREFORE, ALL TEST/REQUIREMENTS SPECIFIED IN THE LATEST REVISION OF THE FOLLOWING AGENCY STANDARDS WILL BE MET:

UL APPROVED 10A 440V 50Hz/60Hz 40°C  
 CSA APPROVED 10A 440V 50Hz/60Hz 40°C

OPERATING SPECIFICATION

LINE CURRENT/VOLTAGE: 10A, 440VAC  
 LINE FREQUENCY: 50/60Hz

MAXIMUM LEAKAGE CURRENT: 8.5mA @ 230VAC, 50Hz

OPERATING AMBIENT TEMPERATURE RANGE @ RATED CURRENT: -25°C TO +40°C

IN AN AMBIENT, T<sub>a</sub>, HIGHER THAN 40°C, THE MAXIMUM OPERATING CURRENT, I<sub>o</sub>, IS AS FOLLOWS:

$$I_o = I_r \sqrt{\frac{85 - T_a}{45}}$$

RELIABILITY SPECIFICATIONS

STORAGE TEMPERATURE: -40°C TO +85°C  
 HUMIDITY: 21 DAYS @ 40°C AND 95% RH

TEST SPECIFICATIONS

INDUCTANCE, NOMINAL: 7.5mH

CAPACITANCE @ 1kHz

LINE TO GROUND, NOMINAL: 1.1µF  
 NEUTRAL TO GROUND, NOMINAL: 2.2µF  
 LINE TO NEUTRAL, NOMINAL: 2µF

DISCHARGE RESISTOR

L/L I.R. 2MΩ 1W  
 L/N I.R. 1MΩ 1W  
 L/G I.R. 2MΩ 1W  
 N/G I.R. 1MΩ 1W  
 IR (NO DISCHARGE RESISTOR) 20°C, 50% RH AND 100VDC, MIN: 6MΩ

RECOMMENDED RECEIVING INSPECITON HIPOT

LINE TO GROUND FOR 1 MINUTE: 2632VDC  
 LINE TO LINE FOR 1 MINUTE: 1892VDC  
 LINE TO NEUTRAL FOR 1 MINUTE: 1093VDC

FILTER APPROVAL

THE BEST WAY TO SELECT AND QUALIFY A FILTER IS FOR YOUR ENGINEERING TO TEST THE UNIT IN YOUR EQUIPMENT.

TYPICAL INSERTION LOSS  
 COMMON MODE 50/50Ω; DIFFERENTIAL MODE 50/50Ω

MHz	0.01	0.05	0.15	0.5	1	3	5	10	30
CM	60	60	59	54	50	42	37	32	26
DM	30	31	40	54	46	38	33	29	24

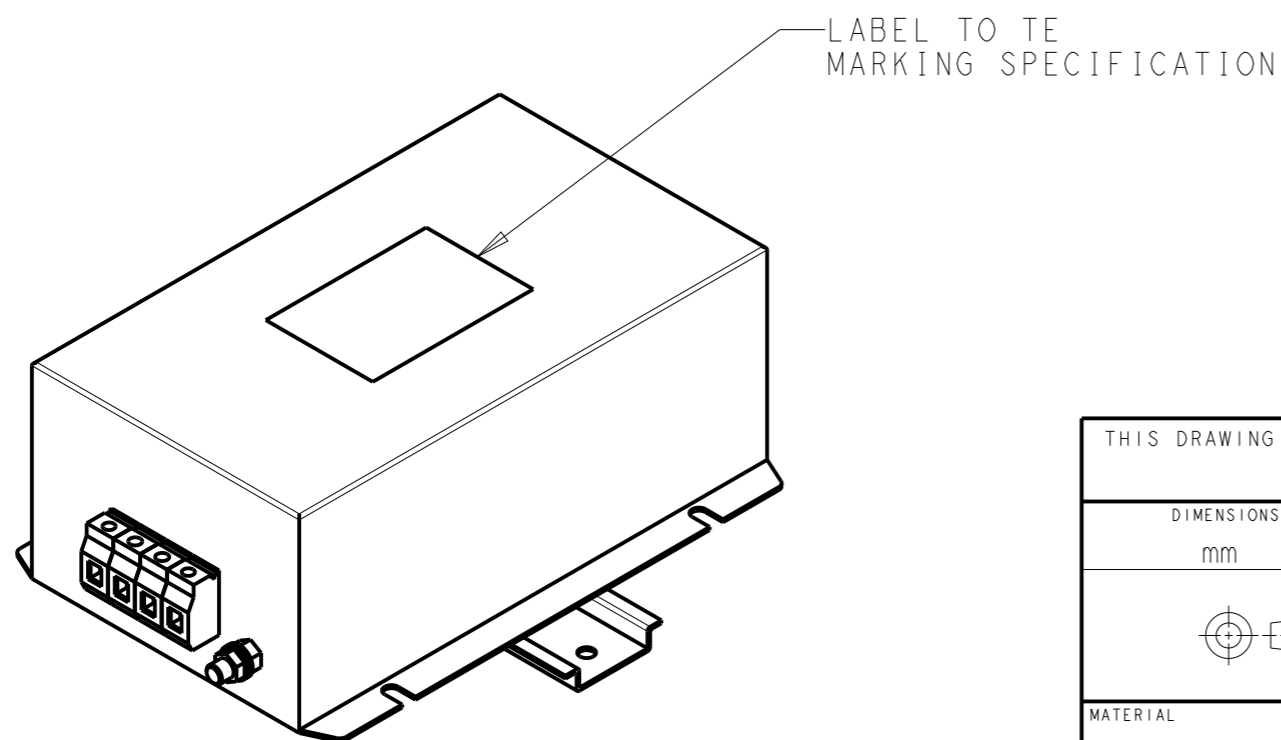

THIS DRAWING IS A CONTROLLED DOCUMENT.		DWN 12APR2021 BAPAT SAHAS		
DIMENSIONS: mm		CHK 12APR2021 CHRIS BOLLE		
TOLERANCES UNLESS OTHERWISE SPECIFIED:		APVD 12APR2021 CHRIS BOLLE	NAME POWER LINE FILTER FOR DIN 35 RAIL INSTALLATION 10KEPS10AFPWHM	
0 PLC ±-		PRODUCT SPEC	SIZE	
1 PLC ±0.5		APPLICATION SPEC	CAGE CODE	
2 PLC ±0.40			DRAWING NO	
3 PLC ±0.130			RESTRICTED TO	
4 PLC ±0.0500			A300779	
ANGLES ±-		WEIGHT	C-8-1609968-4	
MATERIAL			SCALE 1:2	
FINISH			SHEET 1 OF 2	
			REV A	
			CUSTOMER DRAWING	

© 2021 TE Connectivity. All Rights Reserved.

NOTE 1 GROUND CONNECTION:  
 FOR ELECTRICAL SAFETY AND FILTER PERFORMANCE  
 UNIT MUST HAVE A GOOD GROUND CONNECTION.  
 TORQUE OUTER TERMINAL SCREWS: 0.5Nm / 4.5 in.lbs  
 TORQUE GROUND NUTS: 2.5-3Nm

NOTE 2 INPUT OUTPUT CONNECTION TERMINAL  
 AWG SIZE: 26-12 AWG  
 WIRE SECTION: 4 mm<sup>2</sup>  
 THREADED BOLT SIZE FOR GROUND: M6

NOTE 3 SUPPLIED WITH DIN RAIL BRACKET

NOTE 4 DRAWINGS SHOWS DIN RAIL FOR REFERENCE ONLY

REVISIONS					
P	LTR	DESCRIPTION	DATE	DWN	APVD
		SEE SHEET 1			

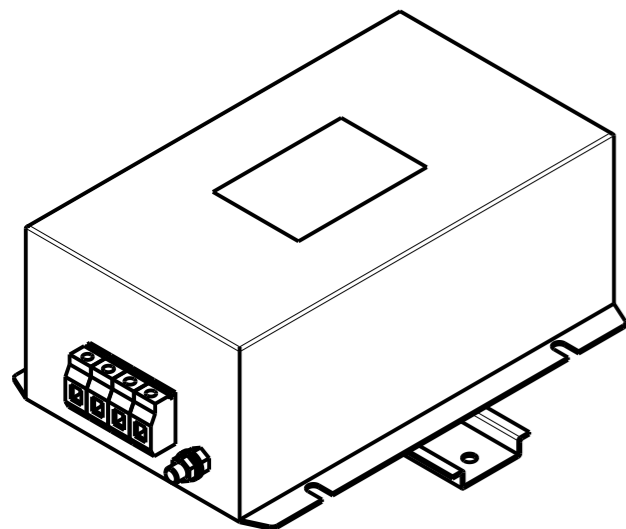
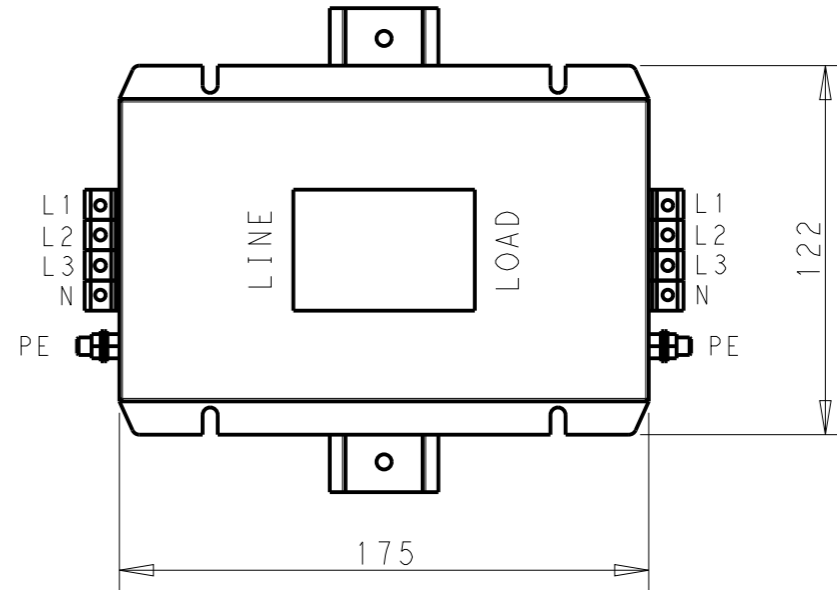
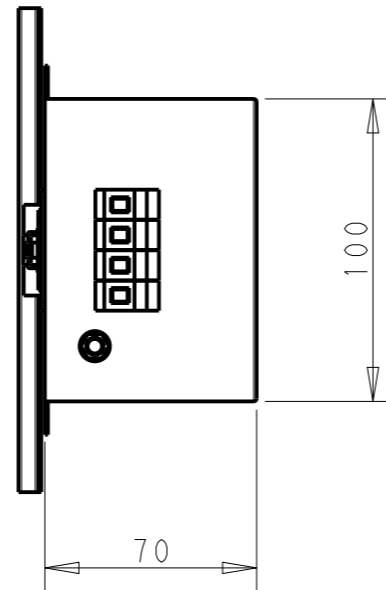
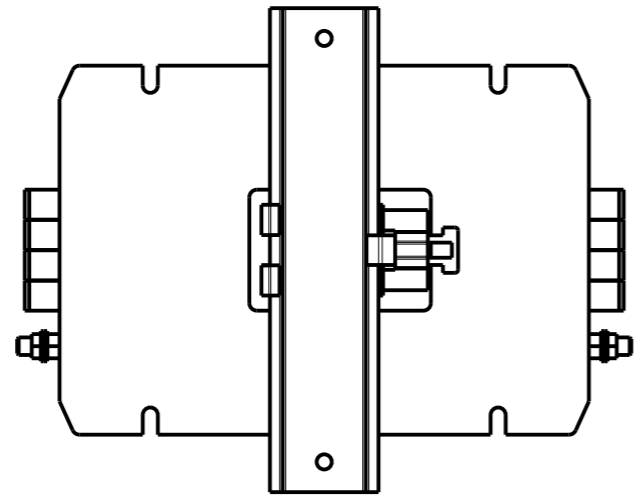

FRONT SIDE

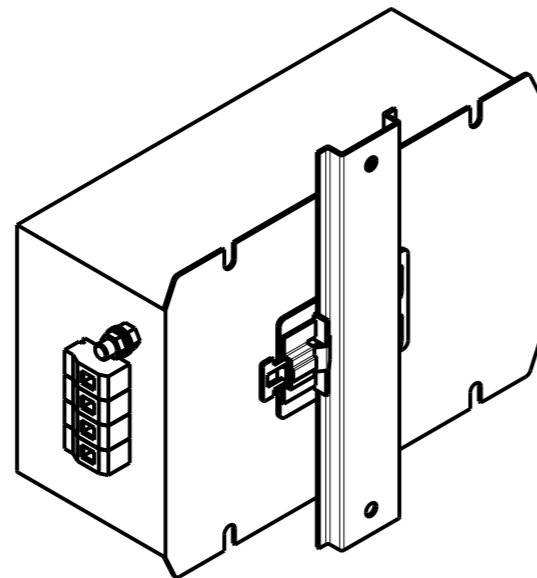

REAR SIDE



DIN RAIL CHANNEL

DIN 35 BRACKET

THIS DRAWING IS A CONTROLLED DOCUMENT.		DWN 12APR2021 BAPAT SAHAS			
		CHK 12APR2021 CHRIS BOLLE			
DIMENSIONS: mm		APVD 12APR2021 CHRIS BOLLE	NAME POWER LINE FILTER FOR DIN 35 RAIL INSTALLATION 10KEPS10AFPWHM		
TOLERANCES UNLESS OTHERWISE SPECIFIED: 0 PLC ±0.5 1 PLC ±0.4 2 PLC ±0.130 3 PLC ±0.0500 4 PLC ANGLES ±		PRODUCT SPEC -	RESTRICTED TO -		
MATERIAL -		APPLICATION SPEC -	SIZE A300779	CAGE CODE C-8-1609968-4	DRAWING NO
FINISH -		WEIGHT -	SCALE 2:5 SHEET 2 OF 2 REV A		
		CUSTOMER DRAWING			