

**HEX-Reg™ 5.1 Volt Zener Diode Array  
for Hex Attenuator Drivers**

**DESCRIPTION**

The SM16Z4689 is designed for supplying the 5 volt bias at 50  $\mu$ A for hex attenuator driver components. These provide the controlling voltage for 6-bit digital GaAs attenuators such as the Hittite HMC424LP3. This low current, 50  $\mu$ A 5.1V zener array provides the necessary bias for the High State, 4.2 – 5.0 V, conditions when it triggers the associated driver. The HEX-Reg™ voltage regulator array is supplied in the SO-16 package with two spare diodes for applications requiring up to eight diodes. A suggested driver circuit in figure 1 illustrates one of the six inputs to a 6-bit attenuator.

**5.1 V REGULATOR  
ARRAY**

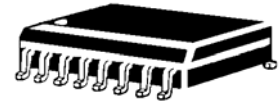

SO-16 Package

**IMPORTANT:** For the most current data, consult MICROSEMI's website: <http://www.microsemi.com>

**FEATURES**

- 8 Diode Array
- SOIC 16-pin Surface Mount Package
- UL 94V-0 Flamability Classification
- IEC 61000-4 compatible
  - 61000-4-2 (ESD): Air 15kV, contact – 8 kV
  - 61000-4-4 (EFT): 40A – 5/50 ns
- RoHS Compliant devices available by adding e3 suffix

**PACKAGING**

- Tape & Reel per EIA Standard 481
- 13 inch reel; 2,500 pieces (OPTIONAL)
- Carrier tubes; 48 pcs (STANDARD)

**MAXIMUM RATINGS**

- Operating Temperature: -55°C to +150°C
- Storage Temperature: -55°C to +150°C
- Power Dissipation ( $P_D$ ): 1500 mW (total)

**MECHANICAL**

- Molded SO-16 Surface Mount
- Finish: Tin-Lead or RoHS Compliant matte-Tin plating solderable per MIL-STD-750 method 2026
- Weight 0.128 grams (approximate)
- Marking: Logo, device number, date code
- Pin #1 defined by dot on top of package

**ELECTRICAL CHARACTERISTICS PER LINE @25°C Unless otherwise specified**

PART NUMBER	PART MARKING	NOMINAL ZENER VOLTAGE $V_z$ (see note 1) volts	ZENER TEST CURRENT $I_{ZT}$ $\mu$ A	MAXIMUM VOLTAGE REGULATION $\Delta V_z$ (see note 2) volts	MAXIMUM REVERSE LEAKAGE CURRENT $I_R$ @ 3 volts $\mu$ A	MAXIMUM DC ZENER CURRENT $I_{ZM}$ mA
SM16Z4689	S16Z4689	5.1	50	0.97	10	55

Note 1. Voltage tolerance is  $\pm 5\%$  @  $I_{ZT}$   
Note 2.  $\Delta V_z$ :  $V_z$  @ 100  $\mu$ A -  $V_z$  @ 10  $\mu$ A

**APPLICATIONS**

The HEX-Reg™ Zener diode array is designed to mount adjacent to a 6-line driver with one of the driver circuits shown below. The 5.1 volt, low-current Zener assures correct bias for the low state and high state of the driven attenuator. Diodes are fully isolated and internally arranged for optimum circuit layout.

Suggested Driver Circuit (one circuit required per bit control)

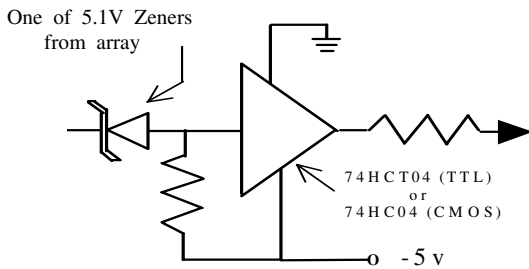

figure 1

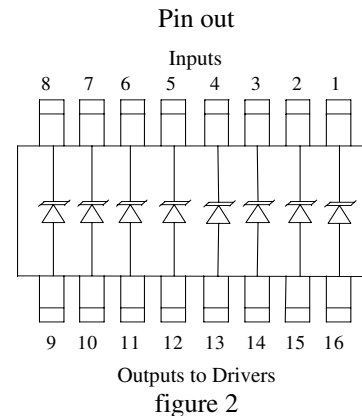
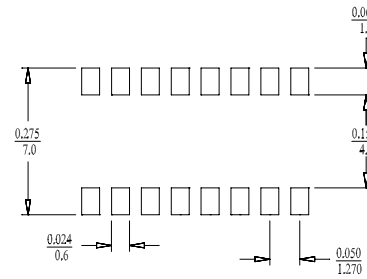
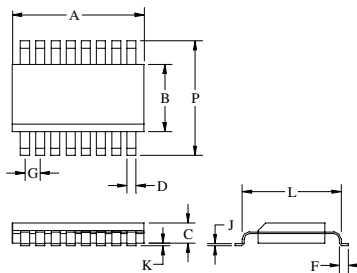

figure 2

**OUTLINE**



**PAD LAYOUT**

INCHES  
MM

DIM	INCHES		MILLIMETERS	
	MIN	MAX	MIN	MAX
A	0.358	0.398	9.09	10.10
B	0.150	0.158	3.81	4.01
C	0.053	0.069	1.35	1.75
D	0.011	0.021	0.28	0.53
F	0.016	0.050	0.41	1.27
G	0.050 BSC		1.27 BSC	
J	0.006	0.010	0.15	0.25
K	0.004	0.008	0.10	0.20
L	0.189	0.206	4.80	5.23
P	0.228	0.244	5.79	6.19

**OUTLINE**