

THIS DRAWING IS UNPUBLISHED. RELEASED FOR PUBLICATION  
 © COPYRIGHT - By - ALL RIGHTS RESERVED.

REVISIONS					
P	LTR	DESCRIPTION	DATE	DWN	APVD
AH		REVISED PER ECO-12-012316	05JUL12	KH	MZ
AJ		REVISED PER ECO-16-017885	06OCT2017	RS	MZ

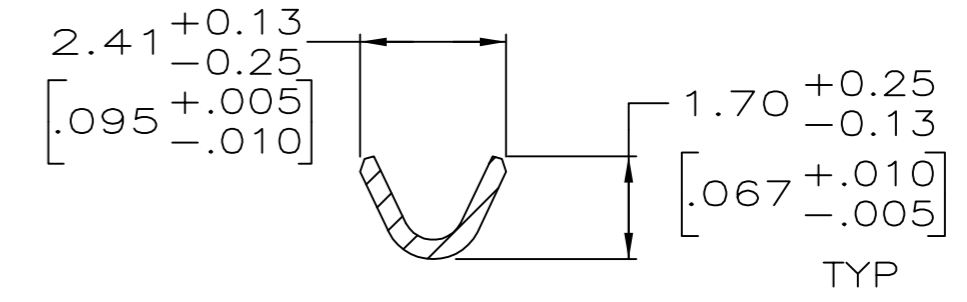

SECTION A-A

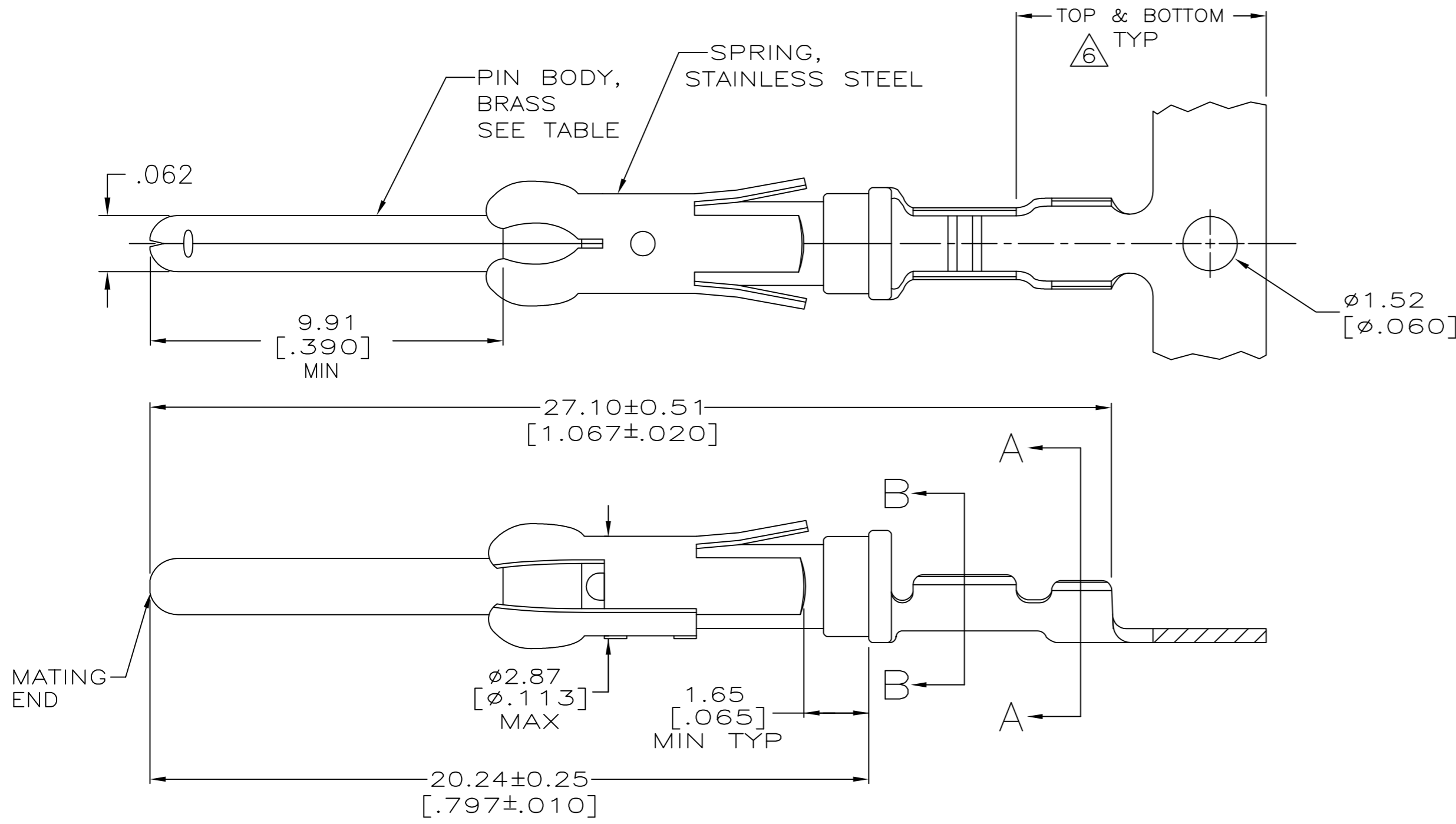
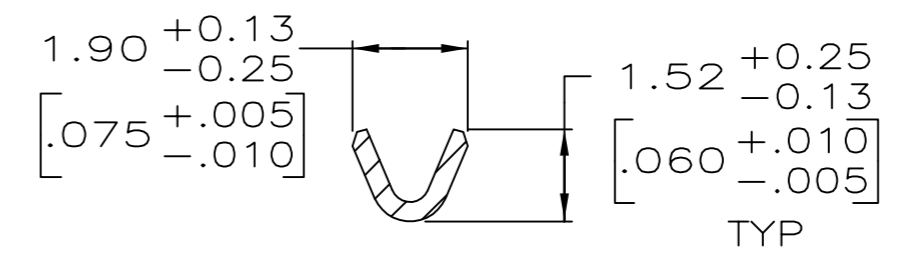

SECTION B-B

- 1 REVERSE REELED FOR MINI-APPLICATOR.
- 2 0.76µm [.000030] MIN PRECIOUS METAL PLATE ON MATING END FOR A LENGTH OF 5.08 [.200] MIN WITH 1.27µm [.000050] MIN MATTE TIN PLATE IN WIRE CRIMP AREA, BOTH OVER 1.27µm [.000050] MIN NICKEL PLATE. CONFORMS TO THE REQUIREMENTS OF TE CONNECTIVITY PRODUCT SPEC 108-10042, BASED ON EIA/ECA-364-1000.01A ( CONTROLLED ENVIRONMENT APPLICATIONS ).
- 3 0.76µm [.000030] MIN PRECIOUS METAL PLATE ON MATING END FOR A LENGTH OF 5.08 [.200] MIN WITH A UNIFORM GRADIENT TO 0.25µm [.000010] ON REMAINDER, OVER 1.27µm [.000050] MIN NICKEL PLATE. GOLD FLASH ALL OVER. CONFORMS TO THE REQUIREMENTS OF TE CONNECTIVITY PRODUCT SPEC 108-10042, BASED ON EIA/ECA-364-1000.01A ( CONTROLLED ENVIRONMENT APPLICATIONS ).
- 4 0.38µm [.000015] MIN GOLD PER MIL-G-45204 ON MATING END FOR A LENGTH OF 5.08 [.200] MIN WITH 1.27µm [.000050] MATTE TIN PATE IN WIRE CRIMP AREA, BOTH OVER 1.27µm [.000050] MIN NICKEL PER QQ-N-290.
- 5 1.27µm [.000050] MIN GOLD PER MIL-G-45204 ON MATING END FOR A LENGTH OF 5.08 [.200] MIN WITH GOLD FLASH ON THE REMAINDER OVER 1.90µm [.000075] MIN NICKEL PER QQ-N-290.
- 6 GOLD PLATING NEED NOT APPEAR IN THIS AREA EXCEPT 1-66106-2 REQUIRES GOLD PLATING ON INSULATION BARREL.
- 7 1.27µm [.000050] MIN TIN-LEAD PER MIL-T-10727 OVER 1.27µm [.000050] MIN NICKEL PER QQ-N-290.
- 8. WIRE RANGE 26-24 AWG.
- 9. INSULATION RANGE 0.89[.035]-1.40[.055] DIA.
- 10 0.38µm [.000015] MIN GOLD PER MIL-G-45204 ON MATING END FOR A LENGTH OF 5.08 [.200] MIN, 1.27µm [.000050] MIN TIN-LEAD PER MIL-T-10727 FOR A LENGTH OF 5.69 [.224] MIN ON OPPOSITE END, BOTH OVER 1.27µm [.000050] MIN NICKEL PER QQ-N-290 ON ENTIRE CONTACT.
- 11 1.27µm [.000050] MIN TIN PER MIL-T-10727 OVER 1.27µm [.000050] MIN NICKEL PER QQ-N-290.
- 12 0.38µm [.000015] MIN GOLD PER MIL-G-45204 ON MATING END FOR A LENGTH OF 5.08 [.200] MIN 1.27µm [.000050] MIN TIN PER MIL-T-10727 FOR A LENGTH OF 5.69 [.224] MIN ON OPPOSITE END. BOTH OVER 1.27µm [.000050] MIN NICKEL PER QQ-N-290 ON ENTIRE CONTACT.

13 OBSOLETE PARTS: OBSOLETE CIS STREAMLINING PER D.RENAUD/D.SINISI

13	OBSOLETE	1	12	-	1-66106-7
	OBSOLETE	STANDARD	11	1-66107-1	1-66106-6
	OBSOLETE	1	10	66107-8	1-66106-5
	OBSOLETE	1	5	66107-7	1-66106-4
		1	2	66107-4	66106-8
		1	4	66107-3	66106-7
	OBSOLETE	1	7	66107-2	66106-6
		1	3	66107-1	66106-5
		STANDARD	2	66107-4	66106-4
		STANDARD	4	66107-3	66106-3
		STANDARD	7	66107-2	66106-2
	OBSOLETE	STANDARD	3	66107-1	66106-1
		REELING	P/N BODY FINISH	LOOSE PIECE REF	PART NO

THIS DRAWING IS A CONTROLLED DOCUMENT.		DWN R.SHIREY 7-17-91	TE Connectivity	
DIMENSIONS: mm [INCHES]		CHK R.STONE 8-15-91		
TOLERANCES UNLESS OTHERWISE SPECIFIED:		APVD J.WESTMAN 8-19-91	NAME	
0 PLC ± -		PRODUCT SPEC	PIN ASSEMBLY, .062, TYPE III+	
1 PLC ± -		APPLICATION SPEC	SIZE CAGE CODE DRAWING NO RESTRICTED TO	
2 PLC ± 0.13[.005]			A2 00779 C=66106	
3 PLC ± -			SCALE 8:1 SHEET 1 of 1 REV AJ	
4 PLC ± -				
ANGLES ± -				
FINISH		WEIGHT -		
SEE CALLOUTS		SEE TABLE	CUSTOMER DRAWING	