

PRODUCT NO  
SEE TABLE

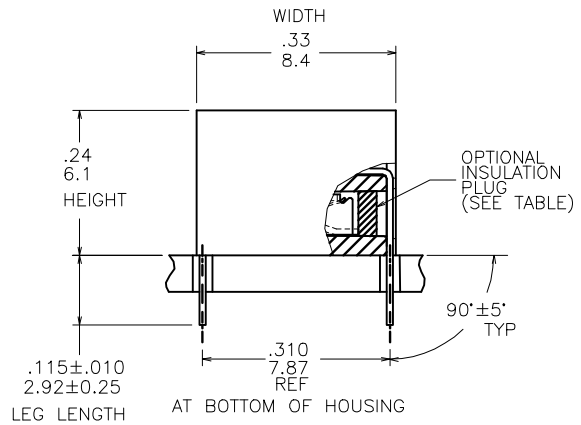
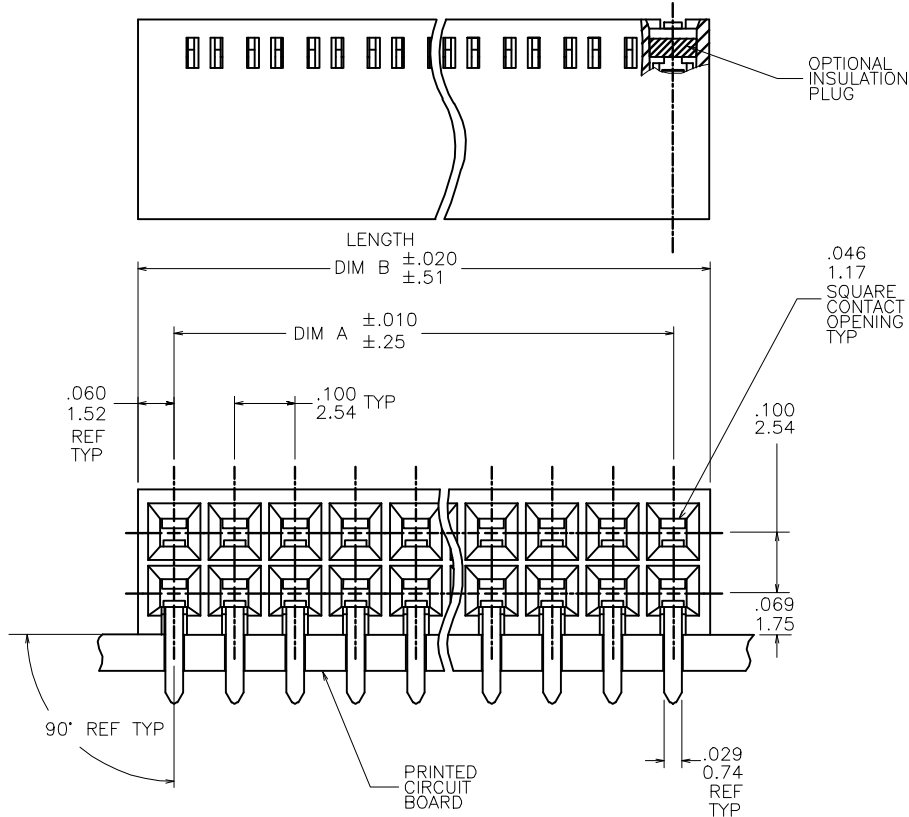

FCconnect.com

Copyright FCI

mat'l. code		surface		tolerance		projection		product family									
-		ISO 1302		ISO 406 ISO 1101				CARD CONN									
Ltr		ecm no	dr	date		tolerances unless otherwise specified		title									
L	V70997	EPK	9/24/97			<table border="1"> <tr> <td>angles</td> <td>linear</td> </tr> <tr> <td></td> <td>XXX ±.01/XXX.03</td> </tr> <tr> <td></td> <td>XXX ±.005/XXX.013</td> </tr> <tr> <td></td> <td>XXX ±.0020/XXX.0051</td> </tr> </table>		angles	linear		XXX ±.01/XXX.03		XXX ±.005/XXX.013		XXX ±.0020/XXX.0051	2 x .100/2.54 HORIZ. CARD CONNECTOR	
angles	linear																
	XXX ±.01/XXX.03																
	XXX ±.005/XXX.013																
	XXX ±.0020/XXX.0051																
M	V02518	MDF	10/27/00			INCH/MM		dwg no									
N	M05-0181	MHT	8/17/05	0° ±2'		scale 4:1		sheet 1 of 6 size									
P	M06-0117	AEA	6/26/06	dr	E.J. HALEY	10/29/87		67118 A3									
R	M07-0137	MHT	2/26/07	engr	M. HAHN	10/29/87		type									
S	M08-0232	MHT	8/14/08	chr	M. HAHN	10/29/87		Product Customer Drawing									
T	M09-0093	MHT	6/22/09	appd	M. HAHN	10/29/87											
sheet	revision		T	T	T	T	T	T	T								
index	sheet	1	2	3	4	5	6										



form: A3

PRODUCT NO  
SEE TABLE

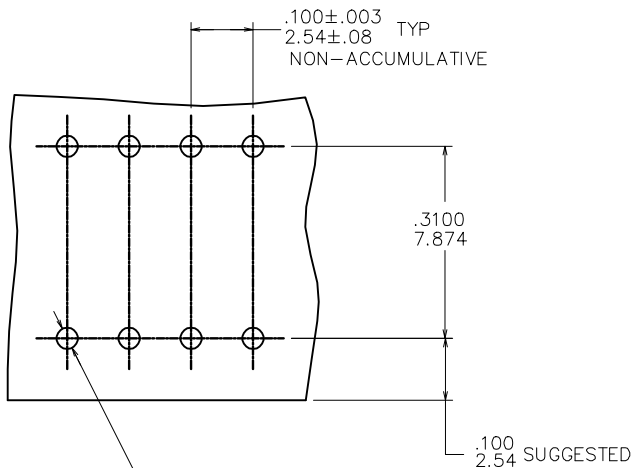

FIGURE 1  
SCALE 4/1

- 8. THIS PART WILL WITHSTAND EXPOSURE TO 260°C PEAK TEMPERATURE FOR 20 SECONDS IN A WAVE SOLDER, INFRA-RED OR VAPOR PHASE SOLDER PROCESS.
- 9. THIS PRODUCT HAS 100% TIN PLATING IN THE INTERFACE AND HAS NOT BEEN TESTED FOR WISKER GROWTH IN ALL INTERCONNECT REQUIREMENTS
- 10. PLATING OPTIONS:  
MAY BE EITHER GOLD OR GXT PLATED AT MANUFACTURER'S OPTION.

NOTES

- ① HOUSING MATERIAL:  
FILLED HIGH TEMPERATURE NYLON  
COLOR: BLACK
- ② TERMINAL MATERIAL:  
BODY: BRASS, .010/0.25 THICK  
SPRING: BE-CU, HEAT TREATED  
BODY PLATING:  
30 MICROINCH/0.76 MICRON GOLD OR GXT  
OVER 50 MICROINCH/1.27 MICRON NICKEL  
IN CONTACT AREA  
SOLDERTAIL PLATING:  
100 MICROINCH/2.54 MICRON PURE TIN (NOTE 9)  
OVER 50 MICROINCH/1.27 MICRON NICKEL  
SPRING PLATING: GOLD FLASH
- 3. APPLICATION INFORMATION:  
A. RECOMMENDED MOUNTING HOLE PATTERN IS SHOWN IN FIGURE "1"  
B. ALL MATING PINS TO BE .025/0.64 SQUARE ON TRUE CENTER OF GIVEN TERMINAL SPACINGS WITHIN .015/0.38 DIA.  
C. SUGGESTED MATING PIN LENGTH .350/8.89 ± .020/0.51
- ④ SPECIAL MARKING
- ⑤ TERMINAL MATERIAL:  
BODY: BRASS, .010/0.25 THICK  
SPRING: BE-CU, HEAT TREATED  
BODY PLATING:  
30 MICROINCH/0.76 MICRON GOLD  
OVER 50 MICROINCH/1.27 MICRON NICKEL  
IN CONTACT AREA  
SOLDERTAIL PLATING:  
3 MICROINCH/.076 MICRON GOLD  
OVER 50 MICROINCH/1.27 MICRON NICKEL  
SPRING PLATING: GOLD FLASH
- ⑥ ADD "LF" SUFFIX AT THE END OF PART NUMBER FOR LEAD FREE OPTION.
- ⑦ THESE PRODUCT MEETS EUROPEAN UNION DIRECTIVES AND OTHER COUNTRY REGULATIONS AS DESCRIBED IN GS-22-008



FCIconnect.com

Copyright FCI

mat'l. code		surface ISO 1502		tolerance ISO 406 ISO 1101		projection		product family CARD CONN	
litr		ecn no		dr		date		title	
T								2 x .100/2.54 HORIZ. CARD CONNECTOR	
		angles		linear		INCH/MM		dwg no	
		0° ± 2'		XXX ± 0.01/XXX ± 0.13		scale 4:1		sheet 2 of 6 size	
		dr		engr		chr		A3	
		E.J. HALEY		M. HAHN		M. HAHN		67118	
		10/29/87		10/29/87		10/29/87		Product Customer Drawing	
sheet		revision		appd		M. HAHN		type	
index		sheet							

PRODUCT NO	NO. OF POS.	DIM A	DIM B	INSUL. PLUG.	PLATING	LEAD FREE OPTION
67118-001	2X1	.00/0	.14/3.56	NO		NOTE-6,7
-002	2X2	.10/2.54	.24/6.10		NOTE 5	
-003	2X3	.20/5.08	.34/8.64		NOTE 5	
-004	2X4	.30/7.62	.44/11.18		NOTE 5	
-005	2X5	.40/10.16	.54/13.72		NOTE 2	
-006	2X6	.50/12.70	.64/16.26			
-007	2X7	.60/15.24	.74/18.80			
-008	2X8	.70/17.78	.84/21.34			
-009	2X9	.80/20.32	.94/23.88			
-010	2X10	.90/22.86	1.04/26.42			
-011	2X11	1.00/25.40	1.14/28.96			
-012	2X12	1.10/27.94	1.24/31.50			
-013	2X13	1.20/30.48	1.34/34.04			
-014	2X14	1.30/33.02	1.44/36.58			
-015	2X15	1.40/35.56	1.54/39.12			
-016	2X16	1.50/38.10	1.64/41.66			
-017	2X17	1.60/40.64	1.74/44.20			
-018	2X18	1.70/43.18	1.84/46.74			
-019	2X19	1.80/45.72	1.94/49.28			
-020	2X20	1.90/48.26	2.04/51.82			
-021	2X21	2.00/50.80	2.14/54.36			
-022	2X22	2.10/53.34	2.24/56.90			
-023	2X23	2.20/55.88	2.34/59.44			
-024	2X24	2.30/58.42	2.44/61.98			
-025	2X25	2.40/60.96	2.54/64.52			
-026	2X26	2.50/63.50	2.64/67.06			
-027	2X27	2.60/66.04	2.74/69.60			
-028	2X28	2.70/68.58	2.84/72.14			
-029	2X29	2.80/71.12	2.94/74.68			
-030	2X30	2.90/73.66	3.04/77.22			
-031	2X31	3.00/76.20	3.14/79.76			
-032	2X32	3.10/78.74	3.24/82.30			
-033	2X33	3.20/81.28	3.34/84.84			
-034	2X34	3.30/83.82	3.44/87.38			
-035	2X35	3.40/86.36	3.54/89.92			
-036	2X36	3.50/88.90	3.64/92.46			
-037	2X37	3.60/91.44	3.74/95.00			
-038	2X38	3.70/93.98	3.84/97.54			
-039	2X39	3.80/96.52	3.94/100.08			
67118-040	2X40	3.90/99.06	4.04/102.62	NO	NOTE 2	NOTE 6,7

mat'l. code	surface ISO 1302	tolerance ISO 406 ISO 1101	projection	product family
litr	ecn no	dr	date	title
T				2 x .100/2.54 HORIZ. CARD CONNECTOR
	angles	linear	0 ± 2'	scale 4:1
				dwg no 67118 sheet 3 of 6 size A3
	dr	engr	chr	appd
	E.J. HALEY	M. HAHN	M. HAHN	M. HAHN
	10/29/87	10/29/87	10/29/87	10/29/87
sheet index	revision	sheet		



FCconnect.com

Copyright FCJ

PRODUCT NO	NO. OF POS.	DIM A	DIM B	INSUL. PLUG	PLATING	LEAD FREE OPTION
67118-041	2X41	4.00/101.60	4.14/105.16	NO	NOTE 2	NOTE 6,7
-042	2X42	4.10/104.14	4.24/107.70			
-043	2X43	4.20/106.68	4.34/110.24			
-044	2X44	4.30/109.22	4.44/112.78			
-045	2X45	4.40/111.76	4.54/115.32			
-046	2X46	4.50/114.30	4.64/117.86			
-047	2X47	4.60/116.84	4.74/120.40			
-048	2X48	4.70/119.38	4.84/122.94			
-049	2X49	4.80/121.92	4.94/125.48			
-050	2X50	4.90/124.46	5.04/128.02			
-051	2X51	5.00/127.00	5.14/130.56			
-052	2X52	5.10/129.54	5.24/133.10			
-053	2X53	5.20/132.08	5.34/135.64			
-054	2X54	5.30/134.62	5.44/138.18			
-055	2X55	5.40/137.16	5.54/140.72			
-056	2X56	5.50/139.70	5.64/143.26			
-057	2X57	5.60/142.24	5.74/145.80			
-058	2X58	5.70/144.78	5.84/148.34			
-059	2X59	5.80/147.32	5.94/150.88			
-060	2X60	5.90/149.86	6.04/153.42			
-061	2X61	6.00/152.40	6.14/155.96			
-062	2X62	6.10/154.94	6.24/158.50			
-063	2X63	6.20/157.48	6.34/161.04			
-064	2X64	6.30/160.02	6.44/163.58			
67118-065	2X65	6.40/162.56	6.54/166.12	NO	NOTE 2	NOTE 6,7



Copyright FCJ

mat'l. code	surface ISO 1302	tolerance ISO 406 ISO 1101	projection 	product family CARD CONN
ltr	ecn no	dr	date	title 2 x .100/2.54 HORIZ. CARD CONNECTOR
T				scale 4:1
	angles	linear		INCH/MM
	0'±2'	.XX±.01/XX±.03		
		.XXX ±.005/XXX±.013		
		.XXX ±.0020/XXX±0.051		
dr	E.J. HALEY	10/29/87		dwg no 67118
engr	M. HAHN	10/29/87		sheet 4 of 6 size A3
chr	M. HAHN	10/29/87		
appd	M. HAHN	10/29/87		type Product Customer Drawing
sheet index	revision sheet			

form A3

PRODUCT NO	NO. OF POS.	DIM A	DIM B	INSUL. PLUG	PLATING	LEAD FREE OPTION
67118-501	2X1	.00/0	.14/3.56	YES		NOTE 6,7
-502	2X2	.10/2.54	.24/6.10		NOTE 5	
-503	2X3	.20/5.08	.34/8.64		NOTE 5	
-504	2X4	.30/7.62	.44/11.18		NOTE 5	
-505	2X5	.40/10.16	.54/13.72		NOTE 2	
-506	2X6	.50/12.70	.64/16.26			
-507	2X7	.60/15.24	.74/18.80			
-508	2X8	.70/17.78	.84/21.34			
-509	2X9	.80/20.32	.94/23.88			
-510	2X10	.90/22.86	1.04/26.42			
-511	2X11	1.00/25.40	1.14/28.96			
-512	2X12	1.10/27.94	1.24/31.50			
-513	2X13	1.20/30.48	1.34/34.04			
-514	2X14	1.30/33.02	1.44/36.58			
-515	2X15	1.40/35.56	1.54/39.12			
-516	2X16	1.50/38.10	1.64/41.66			
-517	2X17	1.60/40.64	1.74/44.20			
-518	2X18	1.70/43.18	1.84/46.74			
-519	2X19	1.80/45.72	1.94/49.28			
-520	2X20	1.90/48.26	2.04/51.82			
-521	2X21	2.00/50.80	2.14/54.36			
-522	2X22	2.10/53.34	2.24/56.90			
-523	2X23	2.20/55.88	2.34/59.44			
-524	2X24	2.30/58.42	2.44/61.98			
-525	2X25	2.40/60.96	2.54/64.52			
-526	2X26	2.50/63.50	2.64/67.06			
-527	2X27	2.60/66.04	2.74/69.60			
-528	2X28	2.70/68.58	2.84/72.14			
-529	2X29	2.80/71.12	2.94/74.68			
-530	2X30	2.90/73.66	3.04/77.22			
-531	2X31	3.00/76.20	3.14/79.76			
-532	2X32	3.10/78.74	3.24/82.30			
-533	2X33	3.20/81.28	3.34/84.84			
-534	2X34	3.30/83.82	3.44/87.38			
-535	2X35	3.40/86.36	3.54/89.92			
-536	2X36	3.50/88.90	3.64/92.46			
-537	2X37	3.60/91.44	3.74/95.00			
-538	2X38	3.70/93.98	3.84/97.54			
-539	2X39	3.80/96.52	3.94/100.08			
67118-540	2X40	3.90/99.06	4.04/102.62	YES	NOTE 2	NOTE 6,7

OBSOLETE  
OBSOLETE  
OBSOLETE  
OBSOLETE



FCconnect.com

Copyright FCJ

mat'l. code		surface ISO 1302		tolerance ISO 406 ISO 1101		projection		product family	
litr		ecn no		dr		date		CARD CONN	
T								title	
				angles		linear		INCH/MM	
				0°±2'				2 x .100/2.54 HORIZ. CARD CONNECTOR	
				dr		E.J. HALEY 10/29/87		scale 4:1	
				engr		M. HAHN 10/29/87		dwg no	
				chr		M. HAHN 10/29/87		sheet 5 of 6 size	
				appd		M. HAHN 10/29/87		67118 A3	
sheet		revision						type	
index		sheet						Product Customer Drawing	

form: A3

PRODUCT NO	NO. OF POS.	DIM A	DIM B	INSUL. PLUG	CUSTOMER RESTRICTED	PLATING	LEAD FREE OPTION
67118-541	2X41	4.00/101.60	4.14/105.16	YES		NOTE 2	NOTE 6,7
-542	2X42	4.10/104.14	4.24/107.70				
-543	2X43	4.20/106.68	4.34/110.24				
-544	2X44	4.30/109.22	4.44/112.78				
-545	2X45	4.40/111.76	4.54/115.32				
-546	2X46	4.50/114.30	4.64/117.86				
-547	2X47	4.60/116.84	4.74/120.40				
-548	2X48	4.70/119.38	4.84/122.94				
-549	2X49	4.80/121.92	4.94/125.48				
-550	2X50	4.90/124.46	5.04/128.02				
-551	2X51	5.00/127.00	5.14/130.56				
-552	2X52	5.10/129.54	5.24/133.10				
-553	2X53	5.20/132.08	5.34/135.64				
-554	2X54	5.30/134.62	5.44/138.18				
-555	2X55	5.40/137.16	5.54/140.72				
-556	2X56	5.50/139.70	5.64/143.26				
-557	2X57	5.60/142.24	5.74/145.80				
-558	2X58	5.70/144.78	5.84/148.34				
-559	2X59	5.80/147.32	5.94/150.88				
-560	2X60	5.90/149.86	6.04/153.42				
-561	2X61	6.00/152.40	6.14/155.96				
-562	2X62	6.10/154.94	6.24/158.50				
-563	2X63	6.20/157.48	6.34/161.04				
-564	2X64	6.30/160.02	6.44/163.58				
-565	2X65	6.40/162.56	6.54/166.12	YES			
67118-801	2X50	4.90/124.46	5.04/128.02	NO	YES	NOTE 2	NOTE 6,7

NOTE 5



FCconnect.com

Copyright FCJ

mat'l. code		surface		tolerance		projection		product family	
-		ISO 1302		ISO 406 ISO 1101				CARD CONN	
T		angles		linear		INCH/MM		title	
		0°±2'		XXX ±.01/XXX.03				2 x .100/2.54 HORIZ. CARD CONNECTOR	
				XXX ±.005/XXX.013		scale 4:1		dwg no	
		dr		E.J. HALEY 10/29/87				sheet 6 of 6 size	
		engr		M. HAHN 10/29/87				67118 A3	
		chr		M. HAHN 10/29/87				type	
		appd		M. HAHN 10/29/87				Product Customer Drawing	
sheet		revision							
index		sheet							

form: A3