

Mixed Signal Power Manager Daughter Card Kit Quickstart Card

Kit Contents – MPM-DC-KIT (RoHS compliant)

Quantity	Description
1	Mixed Signal Power Manager Daughter Card Kit
1	9 V power supply
4	Rubber Feet. If using the MPM-DC with the SmartFusion Evaluation Kit, remove the legs and replace with rubber feet to match the board height.

Overview

Actel's Mixed Signal Power Manager (MPM) Daughter Card Kit enables system designers to evaluate the functionality of Actel's power management solutions in hardware with a four-regulator benchtop power management development system. The MPM Daughter Card includes four regulators, four voltage bias potentiometers, and four fault introduction push-button switches, implementing four fully independent power supplies that can be varied and interrupted to demonstrate the management capabilities of Actel's mixed signal power management solution, MPM.

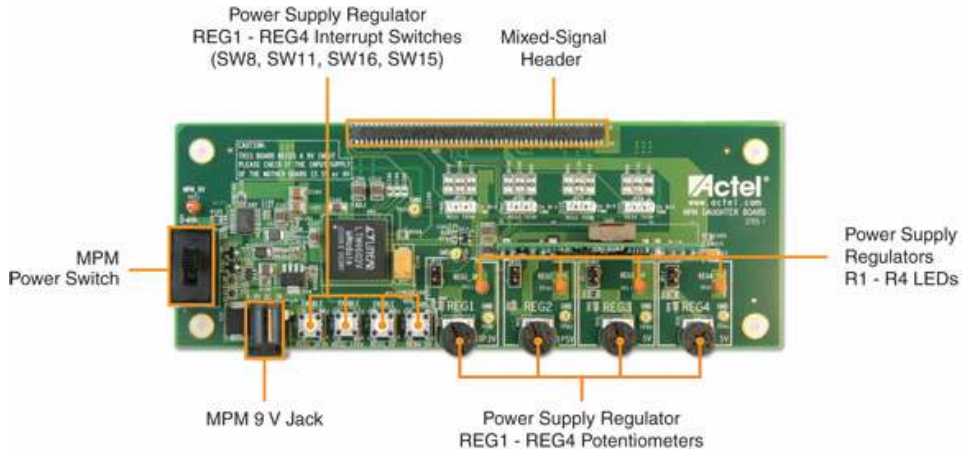

Connections, Jumper Switches, and Settings

Connect jumpers in the default settings to enable the MPM for SmartFusion design to function correctly before powering up the boards.

- Jumpers from FB (feedback voltage) of each regulator for voltage trimming
 - JP12, JP13, JP14, JP15 – Populated with jumper
- Jumpers for selection of PWM or SDD (see the MPM User’s Guide for details)
 - JP17, JP18, JP19, JP20 – Connect pins 1-2
- Push-button switches to disable each regulator and simulate a power failure
 - SW8, SW11, SW15, SW16

Push-button fault injection switches SW8, SW11, SW15, and SW16 ground the enable pin of the corresponding regulator, thereby injecting failure in the power subsystem. However, this enable pin is also connected to the pin on the SmartFusion FPGA (MPM_REG1_EN, MPM_REG2_EN, MPM_REG3_EN, MPM_REG4_EN). The FPGA could be damaged if configured to drive High on the enable line when the fault injection switch is pressed. To avoid this, Actel recommends that the FPGA pin driving this enable should be driving Low or tristated.

MPM Demo Design Description

The MPM demonstration design takes advantage of the processing power and programmable flexibility of the SmartFusion™ intelligent mixed signal FPGA on the SmartFusion Evaluation Kit or Development Kit. Connect either kit to the daughter card and download the software as described to run the demo.

The daughter card consists of four regulated power supplies running from a 9 V supply.

- National switching regulators for 1.5 V and 3.3 V
- Linear Technology and Artesyn DC-DC regulators for 5 V

Using the MPM design one can do the following:

- Monitor voltage for all rails
- Sequence different power rails for power-up and power-down
- Trim and margin a voltage rails in a closed loop
- Sweep the output voltage (POT circuit to change resistor on feedback voltage)
- Induce failures by disabling the enable input of regulator (push-button to GND enable)

Power sequencing is done by sequentially asserting or deasserting channel enable pins for power-up and power-down, respectively, and monitoring the associated channel voltage. All enable pins to the regulator are active high.

Software for MPM Demo Design

Download the MPM Executable which contains the demo design from the Actel website:

http://www.actel.com/products/hardware/devkits_boards/mpm_dc.aspx.

Run the demo design executable. This will install the MPM GUI. From the MPM GUI you can program the demo design into the SmartFusion device and configure your power sequence or trimming. You can update the sequence by uploading only the NVM register locations after the first time you program the main design to the board.

Running the MPM Demo Design

With the SmartFusion Evaluation Kit – Connect the MPM daughter card to the A2F-EVAL-KIT board. Connect both USB cables from your PC to the evaluation kit. One USB provides power and UART connection; the other provides the programming connection. If you are using the daughter card with the evaluation kit, you can remove the plastic legs and add the rubber feet supplied for this purpose.

With the SmartFusion Development Kit – Connect the MPM daughter card to the A2F-DEV-KIT board. Connect the 9 V power supply to the MPM Daughter Card and the 5 V power supply to the development kit. It is a good idea to double check the voltages before connecting the supplies. Connect the low-cost programming stick to the development kit and connect with a USB cable to the PC for programming. Also connect the other USB cable to the USB connection on the board and to your PC.

From the MPM GUI, select **File > Write Device** to load the MPM design to the device for the first time. Use the switches on the evaluation or development kit to activate the power-up sequence. You can then create interrupts and change POT settings to review the performance of the board. The OLED shows the voltage of each of the first four power rails.

- SW1 initiates MPM power-up or power-down, depending on current state
- SW2 moves to the next OLED "screen" (e.g., next channel details)

To change the power sequence, use the GUI to change the settings and then do **File > Write NVM** to update the register settings. It is not necessary to write the device again.

The demo design has many capabilities. To fully understand and use power management, please refer to the documentation.

Documentation Resources

For full information on the daughter card and the usage of the MPM GUI, refer to the MPM User's Guide, Mixed Signal Power Manager Kit website page:

http://www.actel.com/products/hardware/devkits_boards/mpm_dc.aspx#rsc

The source files for the reference design are also available to allow you to adapt and develop your own power management designs. Reference material supplied includes the board schematics and bill-of-materials (BOM).

Software and Licensing

In order to review or edit the reference design, you need Actel's Libero[®] Integrated Design Environment (IDE). This is not required to run the MPM demonstration but is needed only if you want to explore the source files. This can be downloaded from the Actel website (www.actel.com) and used by registering for your free Gold license.

The SmartFusion device uses an ARM[®] Cortex[™]-M3 processor. The application code and project are done using Actel's SoftConsole Eclipse based IDE. This can be installed as part of the Libero IDE install by selecting the SoftConsole option during the installation process. SoftConsole is used for programming and debug of embedded processor designs.

Software releases: www.actel.com/download/software/libero

License Updates: <https://www.actel.com/portal/default.aspx?r=1>

Technical Support and Contacts

Technical support is available online at www.actel.com/support, by email at tech@actel.com, or by phone:

Phone (NA): 800.262.1060

Phone (Int'l): +1 650.318.4460

Actel Sales offices, including Representatives and Distributors, are located worldwide. To find your local representative go to: www.actel.com/company/contact.