

REVISIONS					
P	LTR	DESCRIPTION	DATE	DWN	APVD
S		REVISED PER ECR-18-019874	19MAR2019	BDA	SG

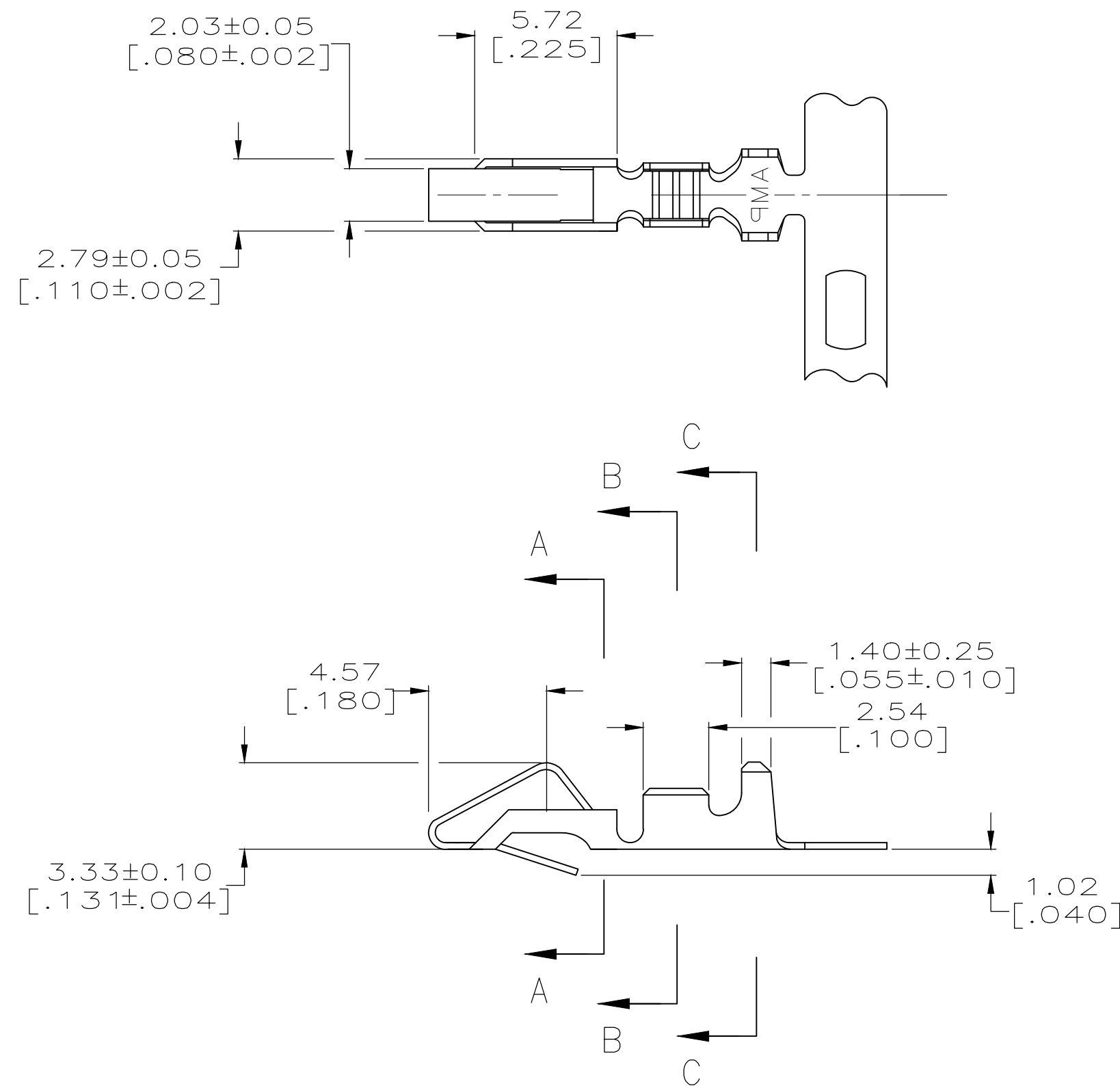

- ① 0.00203 [.000080] MIN MATTE TIN-LEAD OVER 0.00127 [.000050] MIN NICKEL.
- ② 0.00330 [.000130] MAX PRE-TIN.
- ③ 0.00013 [.000005] GOLD OVER 0.00127 [.000050] MIN NICKEL ALL OVER AND 0.00076 [.000030] MIN GOLD ON CONTACT AREA.
- 4. WIRE RANGE: 0.2-0.9mm² (24-18 AWG). INSULATION RANGE: 2.79 [.110] DIA MAX.
- 5. DIMENSIONS IN BRACKETS ARE IN INCHES.
- ⑥ 0.00013 [.000005] GOLD OVER 0.00127 [.000050] MIN NICKEL ALL OVER AND 0.00038 [.000015] MIN GOLD ON CONTACT AREA.
- ⑦ 0.00203 [.000080] MIN MATTE TIN OVER 0.00127 [.000050] MIN NICKEL.
- ⑧ OBSOLETE

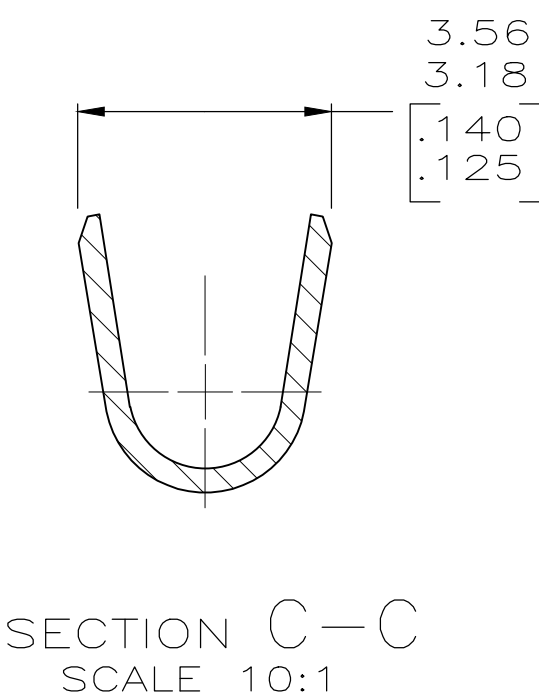
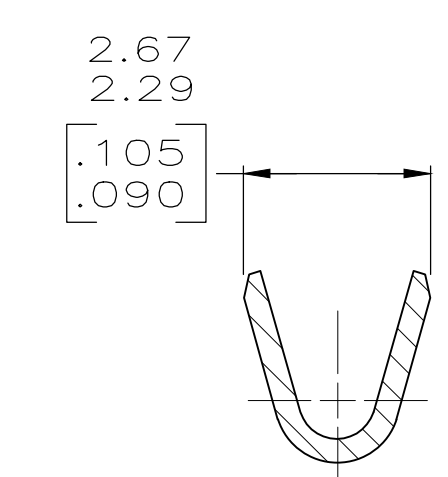
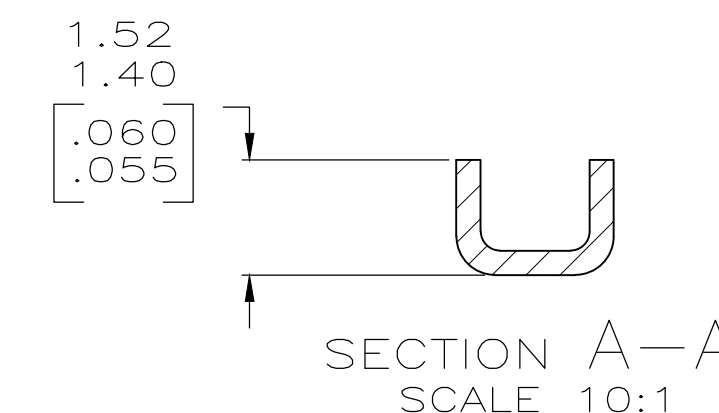

---	⑦	3-350980-1
---	⑥	350980-4
SEE 770258-1	③	350980-3
---	②	350980-2
SEE 640707-1	①	⑧ 350980-1
LOOSE PIECE	FINISH	PART NO

THIS DRAWING IS A CONTROLLED DOCUMENT.		DWN K. SALMON 11-2-92	TE Connectivity Ltd.	
DIMENSIONS: INCHES		CHK R. SWING 11-2-92		
TOLERANCES UNLESS OTHERWISE SPECIFIED:		APVD E. BEILES 11-2-92	NAME RECEPTACLE, SL-156	
0 PLC ± - 1 PLC ± - 2 PLC ± 0.13 [.005] 3 PLC ± - 4 PLC ± - ANGLES ± -		PRODUCT SPEC ---	SIZE A2	
MATERIAL 0.33 [.013] BRASS		FINISH SEE TABLE	APPLICATION SPEC ---	CAGE CODE 00779
		WEIGHT 0.000000	DRAWING NO C-350980	RESTRICTED TO ---
		CUSTOMER DRAWING		SCALE 5:1
				SHEET 1 OF 1
				REV S