



Reference Design Eval Kit STDP4020-RD1

STDP4020

DisplayPort to DVI Output User Guide

Kinetic Technologies cannot assume responsibility for use of any circuitry other than circuitry entirely embodied in a Kinetic Technologies product. No intellectual property or circuit patent licenses are implied. Kinetic Technologies reserves the right to change the circuitry and specifications without notice at any time.



Contents

1. Purpose and Scope.....	4
2. Description	4
3. Set Up Instructions.....	5
3.1. I2C Host Port.....	5
3.2. In-System Programming (ISP).....	6
4. Diagnosis.....	6
4.1. Board Description	7
4.2. Principal Components and Functions	9
4.3. Connector Descriptions.....	10
4.4. Switches.....	14
4.5. Stuffing Options.....	14
4.5.1. Single/dual TTL.....	14
4.5.2. IROM/SPI-Flash.....	14

List of Tables

Table 4.2-1. Principal Components and Functions 9

List of Figures

Figure 1. Connection Diagram: PC DP Signal to Dual link DVI Output 5
Figure 2. Block Diagram 7
Figure 3. Board Picture 8

1. Purpose and Scope

This document provides description and setup instructions for the DisplayPort™ Receiver STDP4020 reference design board [RD1-4020_400-530] targeted for DP to DVI conversion applications.

2. Description

The STDP4020 is an integrated circuit featuring a four lane DisplayPort receiver, quad LVDS & LVTTTL transmitter with I2S and SPDIF audio outputs for digital audio-video conversion application. This device also includes SPI interface, I2C Slave (Host Interface), I2C Master Interface, UART (GProbe) interface, and general-purpose IO pins. The RD1-4020 is a low cost compact four layer board that includes necessary interfaces and features to fully demonstrate the STDP4020 receiver functionalities. The RD1-4020 board includes discrete TMDS transmitter chips, converting LVTTTL output from STDP4020 into DVI. This board is capable of handling both single link and dual link DVI output supporting video resolution from 640 x 480 up to 2560 x 1600. The RD1-4020 also features digital audio outputs SPIDIF and I2S up to 8 Ch.

This reference design meets the following objectives:

1. Stand-alone operation: Includes the necessary firmware (either IROM or external SPI) to work independently; this means the intended functionalities are performed without depending on external (Host) controllers.
2. Slave configuration: Provision to configure the device by an external Host controller through the Host Interface to I2C (most likely when no SPI Flash is used).

3. Set Up Instructions

The picture below [Figure 1] is a connection diagram showing the RD1-4020 board used for transferring a PC DisplayPort signal into a dual link DVI output. Software utility: GProbe tool (ver 5.7.X.X), WinI2C tool

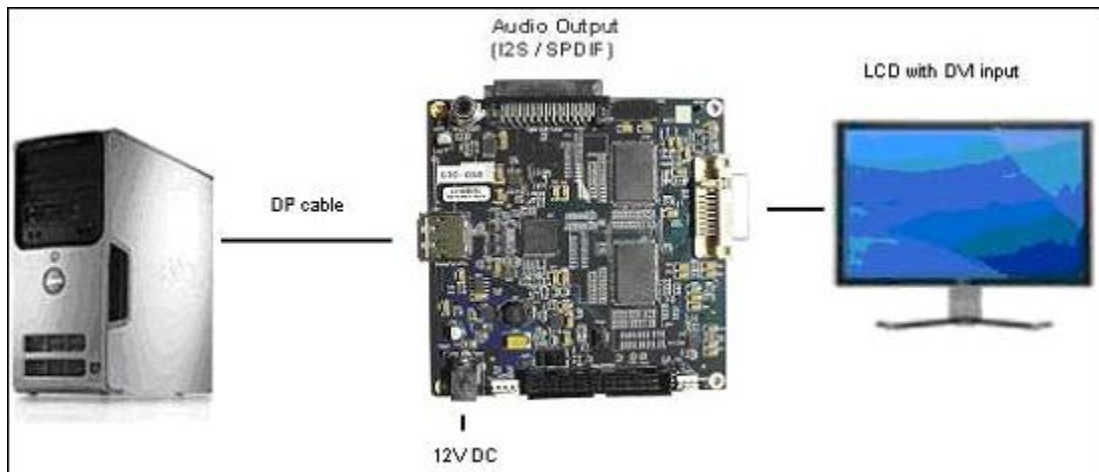

Figure 1. Connection Diagram: PC DP Signal to Dual link DVI Output

This board uses the standard DisplayPort connector recommended in the DP specification to connect the DisplayPort output from the PC to the input of the RD1-4020 board, and a dual link DVI connector to interface with a commercial DVI monitor.

1. Connect the DisplayPort output from a PC source to the RD1-4020 reference board using a DP cable.
2. Connect the output to a DVI monitor using a DVI cable. Connect the 12 V (4A) DC power brick supplied for powering the board. A DisplayPort source that supports DP-Audio transmission is recommended for testing digital audio output of the RD1-4020 board.
3. Once the connection is established, power ON the PC, DVI display, and the RD1-4020 (DP receiver) board. An image should pop up on the screen within 5-6 seconds.

3.1. I2C Host Port

Host connector (CN401) allows configuration of the STDP4020 IC from an external host (microcontroller) through conventional I2C interface. User can plug two wires into pin 5 and pin 6 of this connector to access the I2C port of the chip. STDP4020 default device ID is 0xE6/0xE7, but can be changed through bootstrap settings. Refer to the STDP4020 datasheet for further details.

3.2. In-System Programming (ISP)

RD1-4020 uses SPI Flash to store the firmware. In case of a new firmware upgrade, one of the following methods can be used.

1. ISP through DisplayPort connector: Allows programming the SPI Flash through DisplayPort input connector. Requires DP ISP board and GProbe software tool (contact Kinetic).
2. ISP through UART connector: Allows programming the SPI Flash through UART (RS232) connector. Requires GProbe board (RS232 converter circuit) and GProbe software tool (contact Kinetic).

4. Diagnosis

If the image does not come up, follow the steps below for diagnosis.

Note: The diagnosis requires the Kinetic GProbe software and hardware tool. Contact Kinetic for the GProbe software and board.

1. Install the GProbe diagnostic tool on a computer and set the baud rate to 115,200.
2. Connect Kinetic GProbe board (not supplied) to the serial port (or USB port if using USB version) of the computer.
3. Connect the other end of the GProbe board to connector (CN403) on the RD1-4020 board using 4-wire cable (part of the GProbe board).

Note: CHECK POLARITY while connecting the cable; Pin 1 is marked on the board. The 4-wire cable connection from CN403 to GProbe board is 1 to 1.

4. Hit the Reset button on the board (RESET SW402). You will see the firmware version and date of firmware in the GProbe window. This indicates the DP receiver IC is functional. If the message does not appear, reprogram the Flash using the ISP method described in the GProbe user guide.
5. Using an oscilloscope, check the video input and output from the STDP4020.

Note: Refer to the STDP4020 datasheet for pin out descriptions.

4.1. Board Description

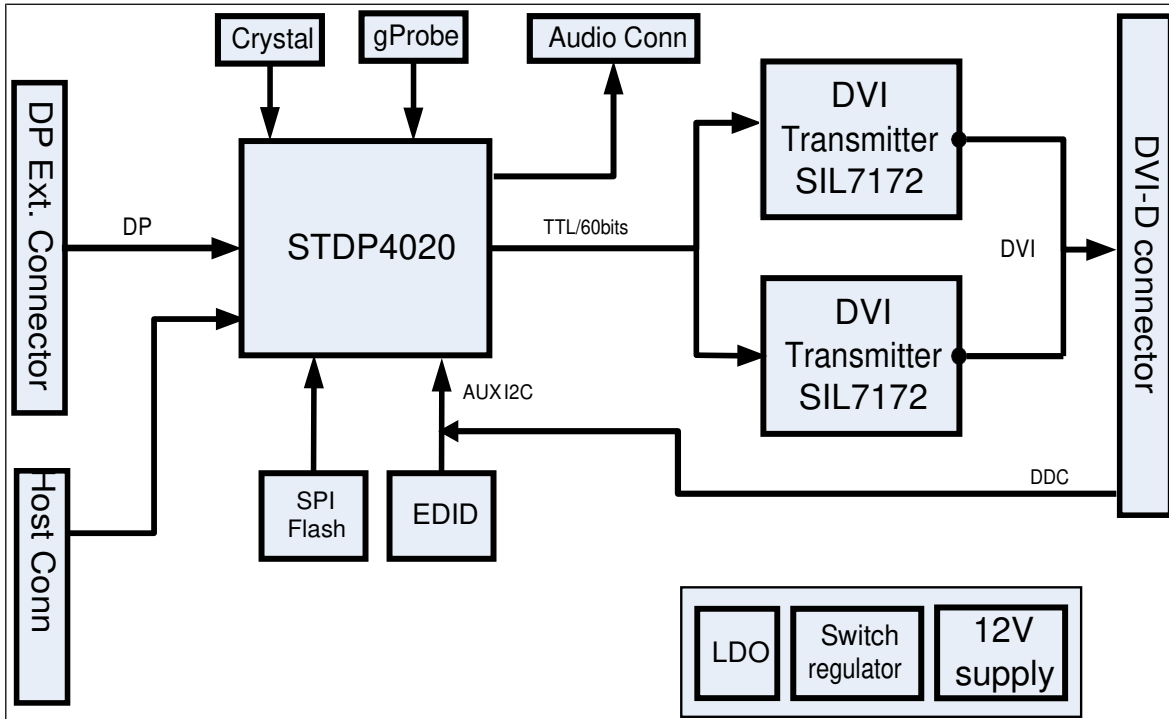

Figure 2. Block Diagram

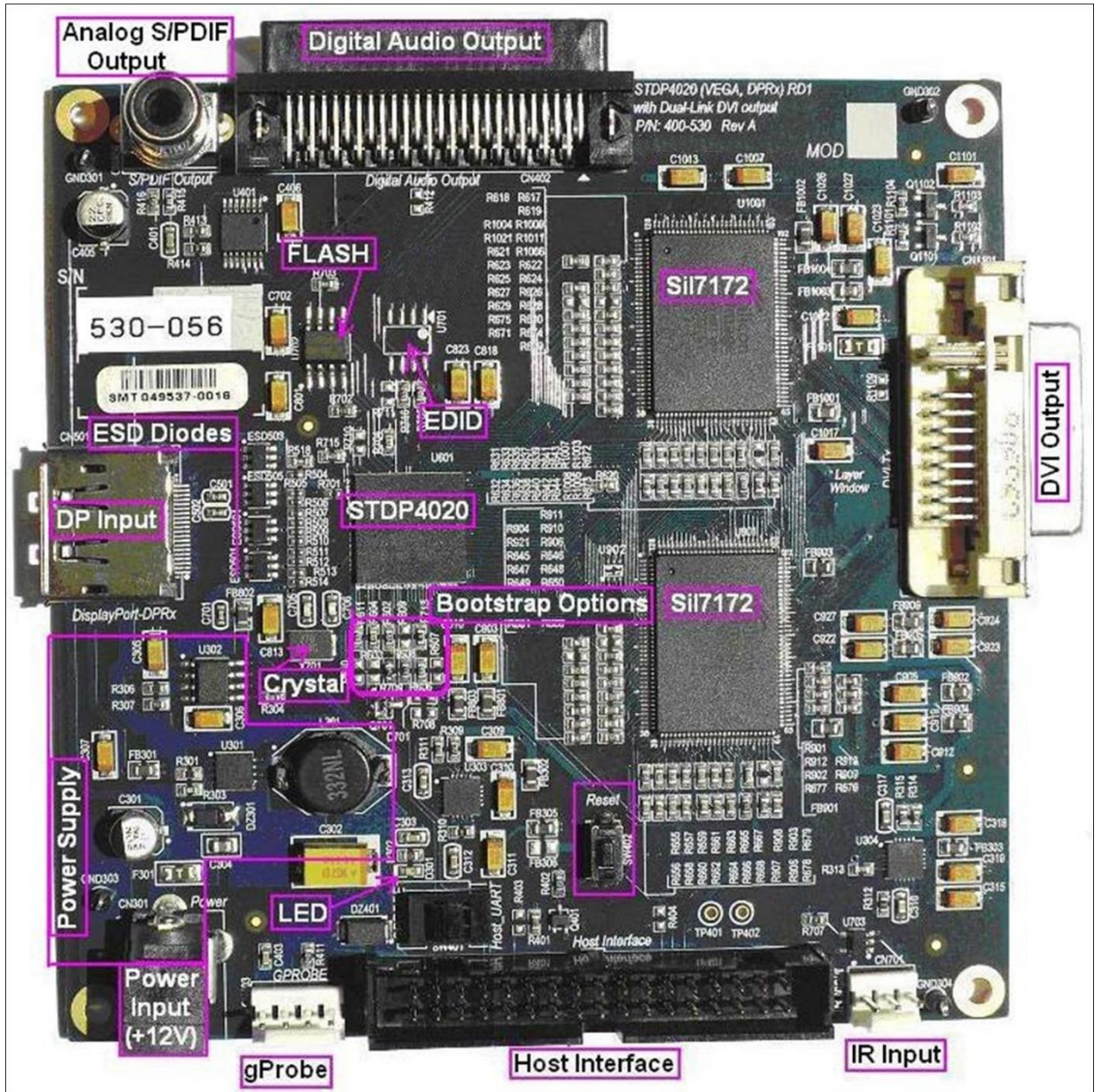

Figure 3. Board Picture

4.2. Principal Components and Functions

Below is a summary of all necessary connectors, switches, and other components. Please refer to the latest board schematics for further details.

Table 4.2-1. Principal Components and Functions

Label	Description	RefDes
Power Input (+12 V)	Input 12 V, down conversion to 5 V, 3.3 V, and 1.2 V. This board uses a switch regulator for 5 V and an LDO [low-dropout] for 3.3 V and 1.2 V. Note the analog and digital supplies (3.3A and 3.3D or 1.2A and 1.2D) are isolated using ferrite beads.	CN301
STDP4020	Kinetic DisplayPort Receiver [STDP4020] is capable of receiving and converting DisplayPort signals into 60-bit LVTTTL output ports that can be mapped to transfer video data either in two pixels per clock or single pixel per clock up to 300 MHz pixel rate. The STDP4020 supports RGB and YCC video color formats with color depth of 12 (YCC 4:2:2 only), 10, and 8 bits.	U601
DP Input	DisplayPort input connector	CN501
Flash	The board includes an SPI Flash of 2 MB to hold the firmware. The SPI Flash can be programmed (ISP) through DP AUX Channel or through UART interface.	U702
DVI Out	DVI output connector	CN1101
Sil7172	Dual-Link DVI transmitters Sil7172	U901, U1001
Digital Audio Output	Digital Audio Output [S/PDIF & I2S in 3.3V logic]: This board supports both compressed and uncompressed audio formats. The extracted audio signal is transferred on a digital audio output bus. This device comprises four I2S audio output ports supporting up to eight channel LPCM audio and a single wire S/PDIF output for encoded audio	CN402
S/PDIF Output	Standard S/PDIF output signal.	CN404
Host Interface	Host Interface (I2C): This board includes a provision to access the STDP4020 device from an external host controller through the Host Interface (I2C port) connection.	CN401
GProbe	GProbe Interface (+3.3 V logic): The board also includes a GProbe connector that connects to the STDP4020 UART port for communication with external PC sources for debug purposes. The Kinetic GProbe tool (software) and PC serial port interface board together create a debug environment for device debug and firmware update. The GProbe interface is also used for ISP purposes.	CN403
Reset	Reset Button, when pressed, triggers a system master reset through the internal reset circuitry. The reset button is used for system reset and debug purposes and is not required for production board design as the STDP4020 produces an internal reset during power ON.	SW402
IR Input	An IR connector for interfacing ST's IR receiver.	CN701
LED	Single LED for indicating the power on status.	D301
Crystal	An external crystal of 27 MHz. The design makes use of internal oscillator circuitry.	X701
ESD Diodes	ESD protection diodes for DisplayPort signal (main lanes, AUX and HPD line). The board implements low cost ESD diodes.	ESD501 ESD503 ESD504 ESD505
EDID	EDID Option: Currently not populated to allow pass through.	U701
SW401	Switches UART between Host Interface & GProbe Interface (see mark on PCB).	SW401
Bootstrap Options	The bootstrap options can be configured for: Single/Dual TTL IROM/ SPI Flash Refer to the datasheet for more details.	R606 R607 R608 R609

4.3. Connector Descriptions

The RD1-4020 has the following connectors. The locations of these connectors are shown in the board picture in Figure 3.

CN301 – +12 V DC 4A Power Input Jack

CN403 – GProbe Interface (4x1 pin keyed header) connects to the UART port of the STDP4020. Use the Kinetic GProbe board and interface cable for connecting the board to an external PC that has GProbe software running.

Pin 1	+5V
Pin 2	GPROBE_TX
Pin 3	GPROBE_RX
Pin 4	GND

CN401 – I2C Host Interface (header 17X2) connector for connecting external host. This is used only when an external host controller accesses the DisplayPort receiver; not used for normal operation. In normal operation, internal MCU controls the overall functioning of the DisplayPort receiver (refer to the schematics for complete pin description for the Host Interface).

Pin 1 & 2	+5V
Pin 3 & 4	GND
Pin 5	I2C_SCL
Pin 6	I2C_SDA
Pin 7	HOST_TX
Pin 8	HOST_RX
Pin 9	RESET from Host
Pin 10	NC
Pin 11 & 12	GND
Pin 13	AUX_UART_TX
Pin 14	AUX_UART_RX
Pin 15	AUX_I2C_SCL
Pin 16	AUX_I2C_SDA
Pin 17 & 18	NC
Pin 19 & 20	GND
Pin 21 & 22	NC
Pin 23	IRQ
Pin 24	IR_IN
Pin 25	I2C_MST_SCL
Pin 26	I2C_MST_SDA
Pin 27 & 28	GND
Pin 29 & 30	NC
Pin 31	TP401
Pin 32	NC
Pin 33	TP402
Pin 34	NC

CN404 – SPDIF output connector.

Pin 1	GND
Pin 2	I2S_0
Pin 3	GND

CN402 – I2S Digital Audio Output (52 pin) connector. Pinout details are shown below.

Pin A1	NC
Pin A2 & A3	GND
Pin A4 through A6	NC
Pin A7	GND
Pin A8 & A9	NC
Pin A10	I2S_3
Pin A11	I2S_2
Pin A12	I2S_1
Pin A13	NC
Pin A14	I2S_0
Pin A15	R412 / OR / I2S_0
Pin A16 & A17	GND
Pin A18	I2S_MCLK
Pin A19 through A21	NC
Pin A22	I2S_BCLK
Pin A23	+5V
Pin A24	I2S_WCLK
Pin A25 & A26	+5V
Pin B1	GND
Pin B2 & B3	NC
Pin B4 & B5	GND
Pin B6 & B7	NC
Pin B8 & B9	GND
Pin B10 through B13	NC
Pin B14 & B15	GND
Pin B16 through B18	NC
Pin B19 & B20	GND
Pin B21	+12V
Pin B22	NC
Pin B23	+12V
Pin B24	NC
Pin B25	+12V
Pin B26	GND

CN1101 – Dual-Link DVI-D connector.

Pin 1	DVI_TX2-
Pin 2	DVI_TX2+
Pin 3	GND
Pin 4	DVI_TX4-
Pin 5	DVI_TX4+
Pin 6	AUX_I2C_SCL
Pin 7	AUX_I2C_SDA
Pin 8	NC
Pin 9	DVI_TX1-
Pin 10	DVI_TX1+
Pin 11	GND
Pin 12	DVI_TX3-
Pin 13	DVI_TX3+
Pin 14	+5V
Pin 15	GND
Pin 16	DVI_HPD_DET
Pin 17	DVI_TX0-
Pin 18	DVI_TX0+
Pin 19	GND
Pin 20	DVI_TX5-
Pin 21	DVI_TX5+
Pin 22	GND
Pin 23	DVI_CLK+
Pin 24	DVI_CLK-
Pin C1 through C4	NC
Pin C5 & C6	GND

CN701 – IR input

Pin 1	GND
Pin 2	+5V
Pin 3	IR_IN

CN501 – DisplayPort connector

Pin 1	ML_L3N
Pin 2	GND
Pin 3	ML_L3P
Pin 4	ML_L2N
Pin 5	GND
Pin 6	ML_L2P
Pin 7	ML_L1N
Pin 8	GND
Pin 9	ML_L1P
Pin 10	ML_L0N
Pin 11	GND
Pin 12	ML_L0P
Pin 13	GND
Pin 14	GND
Pin 15	+3V3_AVDD/AUX_P
Pin 16	GND
Pin 17	GND / AUX_N
Pin 18	HPD_OUT
Pin 19	GND
Pin 20	+3V3_DVDD

4.4. Switches

Host Interface Switch: (SW401): This switch selects the use of GProbe connector or Host Interface connector.

Pin 1	HOST_TX
Pin 2	UART_TX
Pin 3	GPROBE_TX
Pin 4	HOST_RX
Pin 5	UART_RX
Pin 6	GPROBE_RX

4.5. Stuffing Options

4.5.1. Single/dual TTL

Single TTL configuration: stuff R609, unstuff R608

Dual TTL configuration: stuff R608, unstuff R609

4.5.2. IROM/SPI-Flash

OCM boot from IROM code: stuff R607, unstuff R606

OCM boot from external ROM code: stuff R606, unstuff R607