

DESCRIPTION: HIGH DENSITY MALE - SOLDER CUP

DIMENSIONS

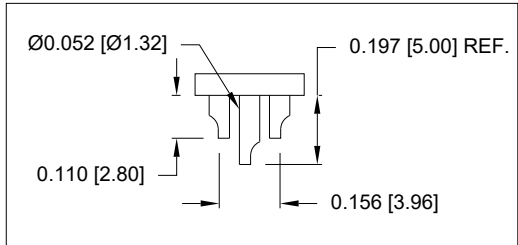
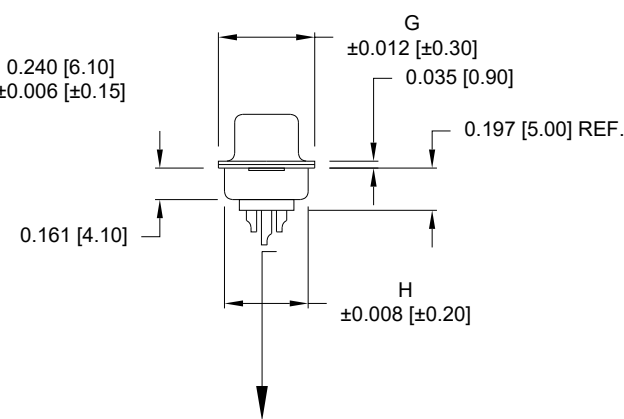
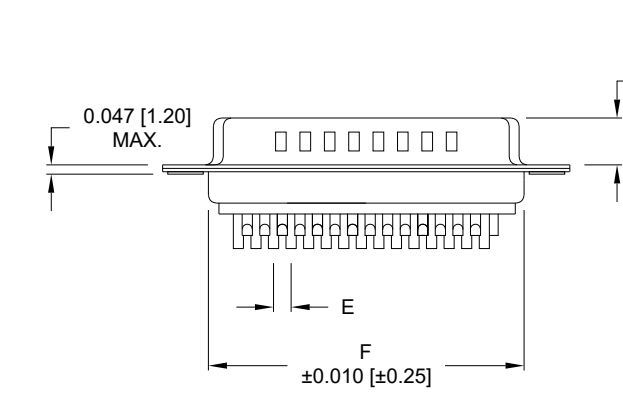
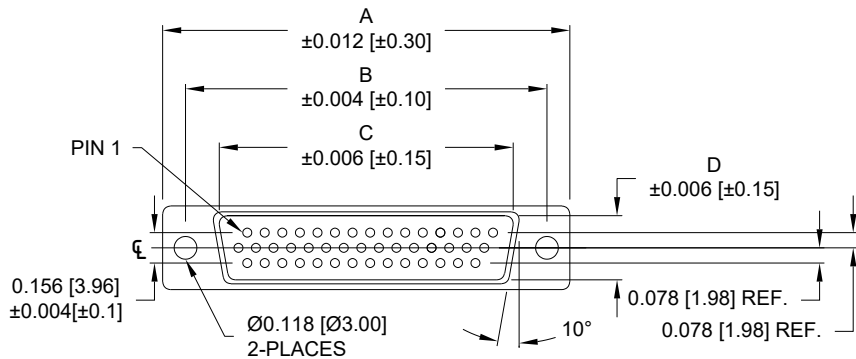

NOTE: WILL ACCEPT UP TO 24 AWG WIRE

4 ROWS

No. OF PINS		A	B	C	D	E	F	G	H
		15	inch	1.213	0.984	0.666	0.329	0.090	0.756
	mm	30.80	24.99	16.92	8.36	2.29	19.20	12.60	10.90
26	inch	1.543	1.312	0.978	0.329	0.090	1.091	0.496	0.429
	mm	39.20	33.32	25.25	8.36	2.29	27.70	12.60	10.90
44	inch	2.087	1.852	1.534	0.329	0.090	1.618	0.496	0.429
	mm	53.00	47.04	38.85	8.36	2.29	41.10	12.60	10.90
62	inch	2.732	2.500	2.181	0.329	0.095	2.256	0.496	0.429
	mm	69.40	63.50	55.40	8.36	2.41	57.30	12.60	10.90
78	inch	2.638	2.406	2.079	0.445	0.095	2.169	0.606	0.526
	mm	67.00	61.10	52.80	11.30	2.41	55.10	15.40	13.35

SPECIFICATIONS:

MATERIALS:
INSULATOR: PBT 30% GF, UL94 V-0 (PROCESS TEMP 230°C)
CONTACTS: GOLD PLATED BRASS OVER NICKEL
SHELL: NICKEL OR TIN PLATED STEEL

ELECTRICAL:

RATED CURRENT: 3A
VOLTAGE: 500VAC FOR 1 MINUTE
INSULATION RESISTANCE: 1000 MOhms MIN.
CONTACT RESISTANCE: 15 mOhms MAX.

ENVIRONMENT:

OPERATING TEMPERATURE: -50°C TO +100°C

180-YYY-10YLYY1

SERIES _____
 POSITIONS _____
 015
 026
 044
 062
 078
 GENDER _____
 1 = MALE
 TERMINATION _____
 0 = SOLDER CUP
 SHELL PLATING _____
 2 = TIN (DISCONTINUED)
 3 = NICKEL (GROUND INDENTS)
 HARDWARE OPTIONS _____
 00 = NO HARDWARE
 01 = .098" CLINCH NUT (SOLDER SIDE)
 02 = .236" CLINCH NUT (SOLDER SIDE)
 03 = .236" CLINCH NUT (MATING SIDE)
 PLATING OPTIONS _____
 1 = GOLD FLASH
 2 = 30u" GOLD MATING AREA; GF ON TAILS

RoHS COMPLIANT

UNITS = inch [mm]

DO NOT SCALE FROM DRAWING



THESE DRAWINGS AND SPECIFICATIONS ARE THE PROPERTY OF NorComp AND SHALL NOT BE REPRODUCED, COPIED OR USED AS THE BASIS FOR THE MANUFACTURE OR SALE OF APPARATUS WITHOUT WRITTEN PERMISSION.

DRAWN: WAYNE ROBBINS
 DATE: 11/29/2005

NorComp

SCALE: NTS SHEET 1 OF 2 REV 18
 DWG NO. 180-YYY-10YLYY1

ALL CLINCH-NUTS ARE 4-40 INTERNAL THREADS

01 0.098" (SOLDER SIDE)

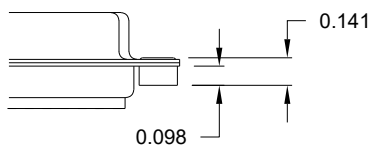

02 0.236" (SOLDER SIDE)

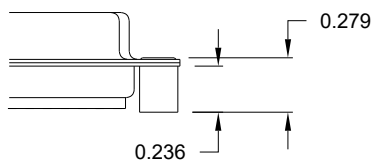

03 0.236" (MATING SIDE)

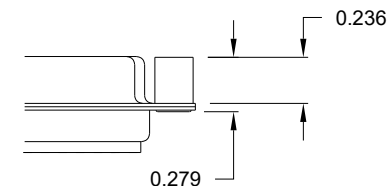

RoHS COMPLIANT

UNITS = inch

DO NOT SCALE FROM DRAWING



THESE DRAWINGS AND SPECIFICATIONS ARE THE PROPERTY OF NorComp AND SHALL NOT BE REPRODUCED, COPIED OR USED AS THE BASIS FOR THE MANUFACTURE OR SALE OF APPARATUS WITHOUT WRITTEN PERMISSION.

DRAWN:
WAYNE ROBBINS

DATE:
11/29/2005

NorComp

SCALE:
NTS

SHEET OF
2 2

REV
18

DWG NO.

180-YYY-10YLYY1