

Synchronous Rectifier Controller for Flyback Converter

SG6203

FEATURES

- Low operation current (1.7mA)
- One resistor for timing setting
- Internal automatic tracking for optimum dead time
- No reverse energy flow at light load
- Best suited for primary green-mode PWM IC
- Wide supply voltage range from 6V to 20V
- Built-in 18V Zener diode
- Optional current sensing:
 - Current shunt
 - RC network for better efficiency

APPLICATIONS

Flyback converters, such as:

- Power adaptors
- Open-frame SMPS

DESCRIPTION

The SG6203 is designed to control and drive the synchronous rectifier for the flyback converter. The synchronous signal of the primary switch is obtained by a single diode connected between the transformer secondary winding and the SG6203. Using the SG6203, no additional transformer winding is required and the circuit complexity can be minimized.

The power unit can be properly operated under discontinuous conduction mode (DCM) or continuous conduction mode (CCM). Problems such as “shoot-through” or “cross conduction” in CCM and energy-reverse from the secondary to the primary in DCM are prevented by the SG6203 design.

TYPICAL APPLICATION

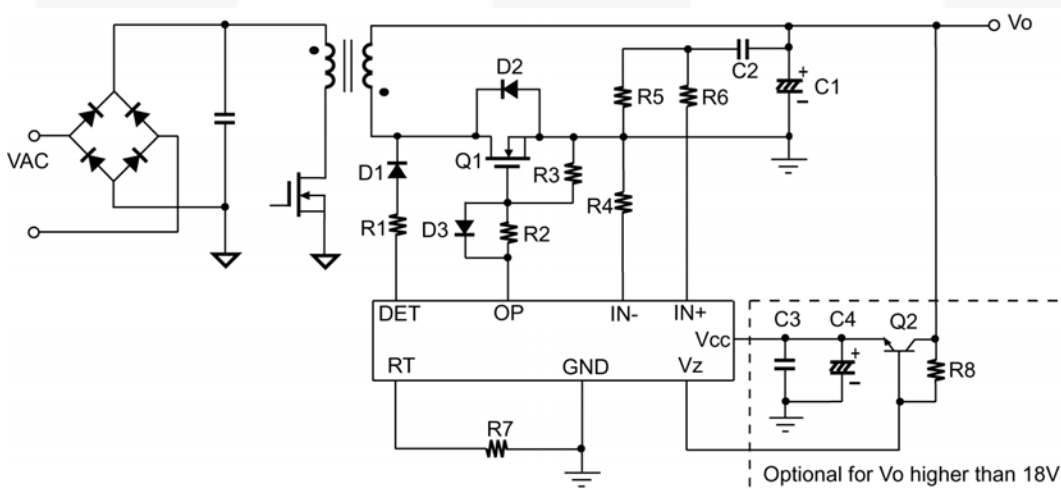

Synchronous Rectifier Controller for Flyback Converter

SG6203

MARKING DIAGRAMS

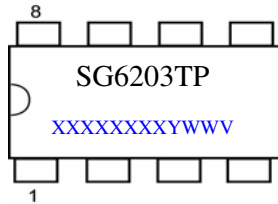

T: D=DIP, S=SOP
P: Z=Lead Free + ROHS Compatible
XXXXXXXX: Wafer Lot
Y: Year; WW: Week
V: Assembly Location

PIN CONFIGURATION

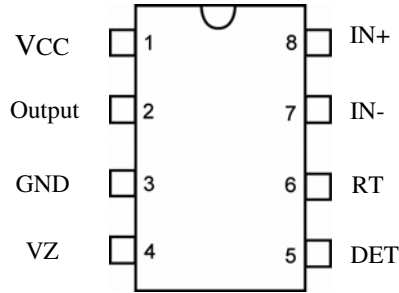

ORDERING INFORMATION

Part Number	Pb-Free	Package
SG6203SZ		8-Pin SOP
SG6203DZ		8-Pin DIP

PIN DESCRIPTIONS

Pin	Name	Function
1	Vcc	Supply voltage of gate driver and control circuits.
2	Output	Totem-pole output to drive the synchronous power MOSFET. When the voltage on DET pin falls below 1.4V from above 2.1V, the synchronous MSOFET is turned on. To prevent the reversed energy flow, this pin is disabled once the voltage on IN+ pin is lower than that of IN- pin or the internal one-shot timer is terminated.
3	GND	The power ground and signal ground. A 0.1μF decoupling capacitor placed between VCC and GND is recommended.
4	VZ	Built-in 18V Zener diode. When the flyback output voltage is higher than 18V, this pin can be used to provide a stable 18V to VCC pin. If the flyback output voltage is lower than 18V, this pin can be left open and the output voltage connected directly to VCC pin.
5	DET	Connecting a diode from this pin to the transformer secondary winding provides on/off information of the primary switch. Low DET level indicates the secondary rectifier is conducted, therefore the synchronous MOSFET should be turned on. DET stays high when the primary switch is conducting or secondary rectifier turns off and the synchronous MOSFET should be turned off.
6	RT	Current reference. Connecting a resistor from this pin to ground can program the internal current reference I_{RT} . Three internal current sources, which are I_{IN+} , I_{IN-} , and I_{DET} , are then mirrored from I_{RT} . I_{RT} determines the duration of the internal one-shot signal, then the maximum on-time of the synchronous MOSFET is obtained by subtracting the on-time of the primary switch from the one-shot signal duration. If the resistor is too small, the synchronous MOSFET may be turned off even when the secondary rectifier is still conducting, which decreases the system efficiency. However, if the resistor is too large, the output is shut off immediately once DET gets high. In SG6203, an internal phase-locked-loop (PLL) modulates the duration of the internal one-shot signal to maintain a suitable dead time between the primary switch and the synchronous MOSFET.
7	IN-	The inverting input of the current sense comparator. In discontinuous conduction mode, the secondary rectifier turns off before the next switching cycle of the primary switch. Once the secondary rectifier is off, the synchronous MOSFET must be turned off to prevent the reversed energy flow. A resistor connected between IN+ and IN- can used to develop the zero current crossing signal of the secondary rectifier. Once the voltage on IN+ is lower than IN-, the output is pulled low.
8	IN+	The non-inverting input of the current sense comparator. In discontinuous conduction mode, the secondary rectifier turns off before the next switching cycle of the primary switch. Once the secondary rectifier is off, the synchronous MOSFET must be turned off to prevent the reversed energy flow. A resistor connected between IN+ and IN- can used to develop the zero current crossing signal of the secondary rectifier. Once the voltage on IN+ is lower than IN-, the output is pulled low.

Synchronous Rectifier Controller for Flyback Converter

SG6203

BLOCK DIAGRAM

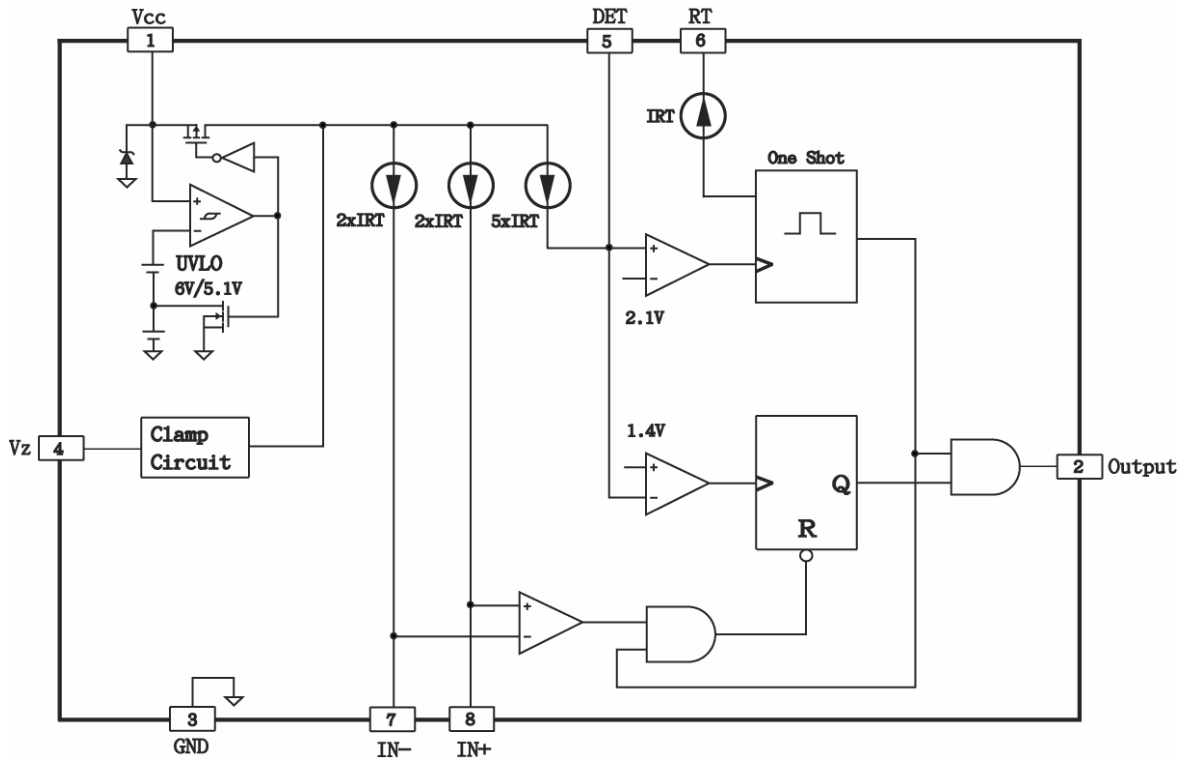

Synchronous Rectifier Controller for Flyback Converter
SG6203
ABSOLUTE MAXIMUM RATINGS

Symbol	Parameter	Value	Unit
V _{CC}	DC Supply Voltage*	25	V
I _{OUT}	Gate Output Current	500	mA
V _H	DET, OUT, VZ	-0.3 to 25.0	V
V _L	RT, IN+, IN-	-0.3 to 7.0	V
P _D	Power Dissipation	SOP8	400
		DIP8	800
R _{θ JA}	Thermal Resistance (Junction-to-Air)	SOP8	208.4
		DIP8	82.5
T _J	Operating Junction Temperature	150	°C
T _{STG}	Storage Temperature Range	-65 to +150	°C
T _L	Lead Temperature (Soldering, 10 Seconds)	300	°C
ESD	Electrostatic Discharge Capability, Human Body Model	2.0	KV
	Electrostatic Discharge Capability, Machine Model	200	V

* All voltage values, except differential voltages, are given with respect to GND pin.

* Stresses beyond those listed under "absolute maximum ratings" may cause permanent damage to the device.

RECOMMENDED OPERATING CONDITIONS

Symbol	Parameter	Value	Unit
V _{CC}	DC Supply Voltage	<20	V
T _A	Operating Ambient Temperature	-30~85	°C
R _T	Pulse Width of the One-shot Signal	12~36	KΩ

ELECTRICAL CHARACTERISTICS

V_{CC}=12V; R_T=24KΩ ; T_A=25°C, unless otherwise noted.

Timing Control Section

Symbol	Parameter	Test Condition	Min.	Typ.	Max.	Unit
V _{RT}	Voltage on RT Pin		1.14	1.20	1.26	V
T _{RT}	Pulse Width of the One-shot Signal	R _T =12KΩ	6.5	7.5	8.5	μs
		R _T =24KΩ	13	15	17	μs
		R _T =36KΩ	19.5	22.5	25.5	μs
Δ T _{RT}	Adjustable Range of the Pulse Width Compared to T _{RT}	R _T =12KΩ ; R _T =24KΩ ; R _T =36KΩ	+40	+60	+80	%
T _{DEAD}	Timing Margin Between Output Turn-off (Output Falling) and Next Switching Cycle Start (DET Rising)		200		1000	ns

Synchronous Rectifier Controller for Flyback Converter

SG6203

Synchronous Detection Section

Symbol	Parameter	Test Condition	Min.	Typ.	Max.	Unit
V _{TH}	Threshold Voltage to Enable One-shot Signal		1.9	2.1	2.3	V
V _{TL}	Threshold Voltage to Enable Output	IN+ - IN- > 5mV	1.2	1.4	1.6	V
I _{DET}	Current Output from DET Pin	R _T =24KΩ		250	300	μA
T _{D_LOW}	Debounce Time from DET Low to Enable Output		150		300	ns

Current Detection Section

Symbol	Parameter	Test Condition	Min.	Typ.	Max.	Unit
V _{OFFSET}	Offset Voltage				10	mV
I _{IN+}	Current Output from IN+	R _T =24KΩ	90	100	110	μA
I _{IN-}	Current Output from IN-	R _T =24KΩ	90	100	110	μA
I _{IN+} - I _{IN-}	Differential Current of IN+ and IN-	12KΩ < R _T < 36KΩ			1.5	μA
T _P	Propagation Delay (OUTPUT from Low to High)	DET < V _{TL} , IN+ - IN- > 5mV			200	ns
PSRR	Power Supply Rejection Ratio			65		dB
CMRR	Common Mode Rejection Ratio			65		dB
CMRR-f	Common Mode Rejection Ratio at 70KHz			32		dB

Zener Section

Symbol	Parameter	Test Condition	Min.	Typ.	Max.	Unit
V _Z	Zener Voltage	I _{VZ} =0.1 ~ 3mA	18	19	20	V

Output Section

Symbol	Parameter	Test Condition	Min.	Typ.	Max.	Unit
V _{OH}	Output Voltage High	V _{CC} =12V, I _{SOURCE} =50mA	11.2			V
		V _{CC} =6V, I _{SOURCE} =30mA	3.5			V
V _{OL}	Output Voltage Low	V _{CC} =12V, I _{SINK} =50mA			1	V
		V _{CC} =6V, I _{SINK} =30mA			1.2	V
Tr	Rising Time	T _A =25°C; C _L =5nF, V _{CC} =12V		150	175	ns
Tf	Falling Time	T _A =25°C; C _L =5nF, V _{CC} =12V		150	175	ns

V_{CC} Section

Symbol	Parameter	Test Condition	Min.	Typ.	Max.	Unit
V _{OP}	Continuously Operating Voltage				20	V
I _{CC_OP}	Operating Current	V _{DD} =12V, Output=open, DET=50KHz, IN-=IN+=open, R _T =12KΩ		1.7	4.0	mA
V _{TH(ON)}	Start Threshold			6.0	6.3	V
V _{TH(OFF)}	Minimum Operating Voltage		4.8	5.1		V

Synchronous Rectifier Controller for Flyback Converter

SG6203

TYPICAL CHARACTERISTICS

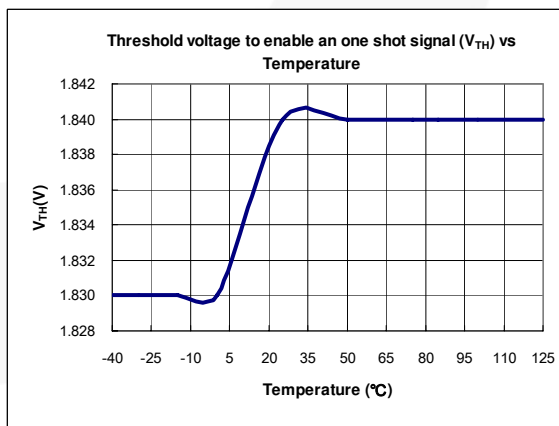
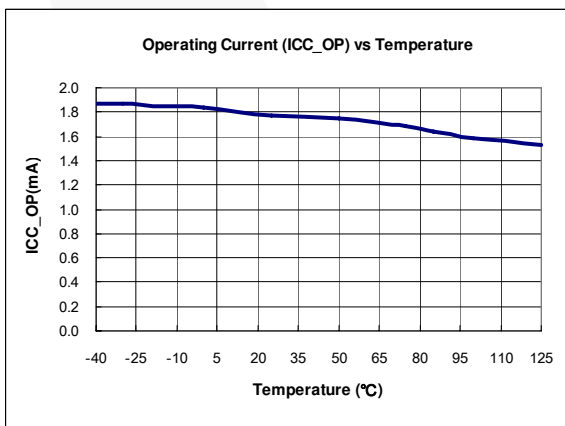
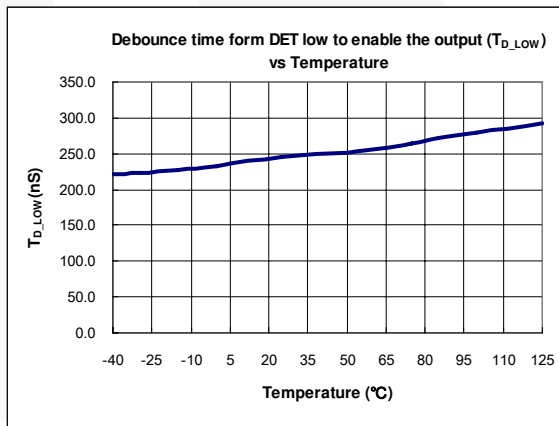
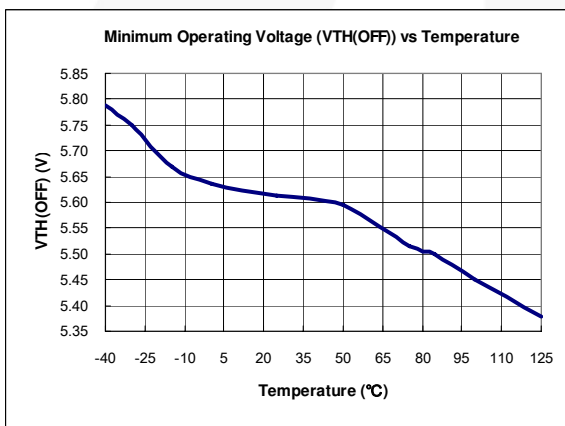
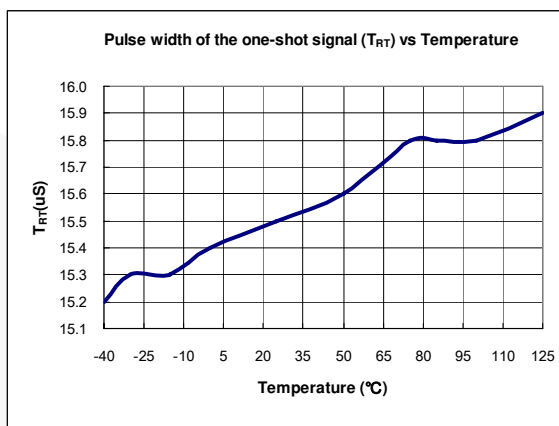
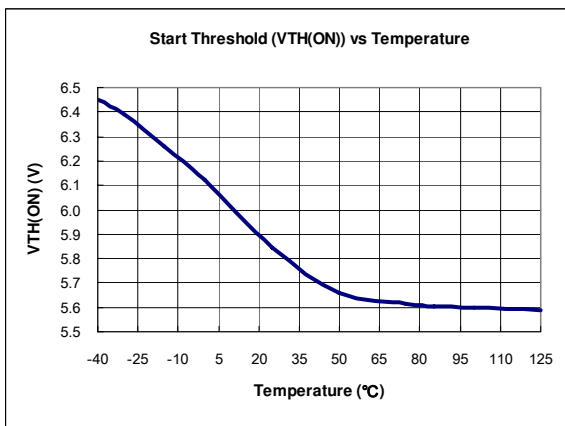

Synchronous Rectifier Controller for Flyback Converter

SG6203

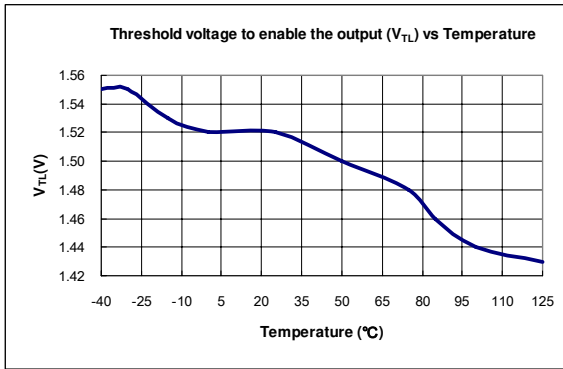

Synchronous Rectifier Controller for Flyback Converter

SG6203

OPERATION DESCRIPTION

Synchronization

The DET pin provides on/off information of the primary switch. As shown in the following reference circuits, one diode connected between the DET pin and the secondary winding of the transformer is used to get this information. Low DET voltage level indicates the secondary rectifier is conducted; therefore, the synchronous MOSFET should be turned on. The voltage on DET pin stays high when the primary switch is conducting and the synchronous MOSFET should be turned off. This innovative feature requires no auxiliary winding and the circuit complexity is greatly reduced.

Anticipation and Phase Lock Loop

A resistor from the RT pin to ground is used to determine the internal current source reference. When the primary switch is turned on with DET high, an internal one-shot timer outputs high for a duration proportional to the RT resistor. The duration of this one-shot signal can be expressed as:

$$T_{RT} = \frac{15 \times R_T (K\Omega)}{24} (\mu s) \tag{1}$$

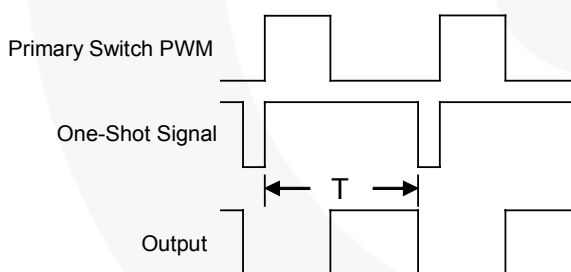

The on-time of the synchronous MOSFET is obtained by subtracting the on-time of the primary switch from the one-shot signal duration. If the resistor is too small, the synchronous MOSFET may be turned off when the secondary rectifier is still conducting, which decreases system efficiency. If the resistor is too large, the output is

shut off immediately once DET gets high. In SG6203, an internal phase locked loop modulates the duration of the internal one-shot signal to maintain a suitable dead time between the primary switch and the synchronous MOSFET. The duration of the one-shot signal can be extended 80% compared with the original value decided by RT resistor.

Current Sense

In discontinuous conduction mode, the secondary rectifier turns off before the next switching cycle of the primary switch. Once the secondary rectifier is off, the synchronous MOSFET must be turned off to prevent the reverse energy flow. Therefore, a zero current crossing detector is needed when the converter is operated under DCM. The SG6203 provides two configurations to achieve this: output capacitor ESR method (reference Circuit-A) and current-sensing resistor method (reference Circuit-B). When the secondary rectifier is turned off, the voltage on IN+ is lower than that of IN-. Once this happens, the driving signal for the synchronous MOSFET is turned off.

Under-Voltage Lockout (UVLO)

The SG6203 has an internal UVLO circuit with hysteresis. The IC is turned on if VCC is higher than 6V. Once turned on, SG6203 is turned off if VCC is lower than 5.1V. When the flyback output voltage is higher than 18V, the VZ pin can be used to provide a stable 18V to VCC pin.

REFERENCE CIRCUIT-A

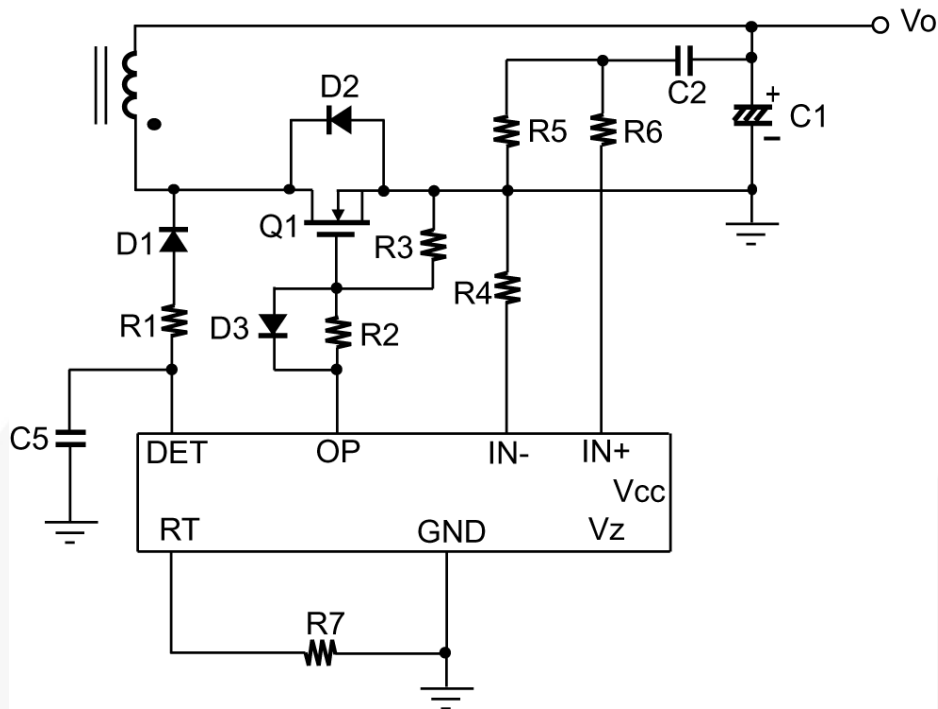

BOM

Ref Des	Part Number	Description
C2		0.1 μ F
C5		22pF
D1	FR102	100V/1A
D2	SB1100	100V/1A
D3	1N4148	100V/0.2A
Q1	PSMN015-110P	110V/75A; 15m Ω
R1		2.2K Ω
R2		22 Ω
R3		47K Ω
R4		1.8K Ω
R5		2K Ω
R6		0
R7		16.2K Ω

REFERENCE CIRCUIT-B

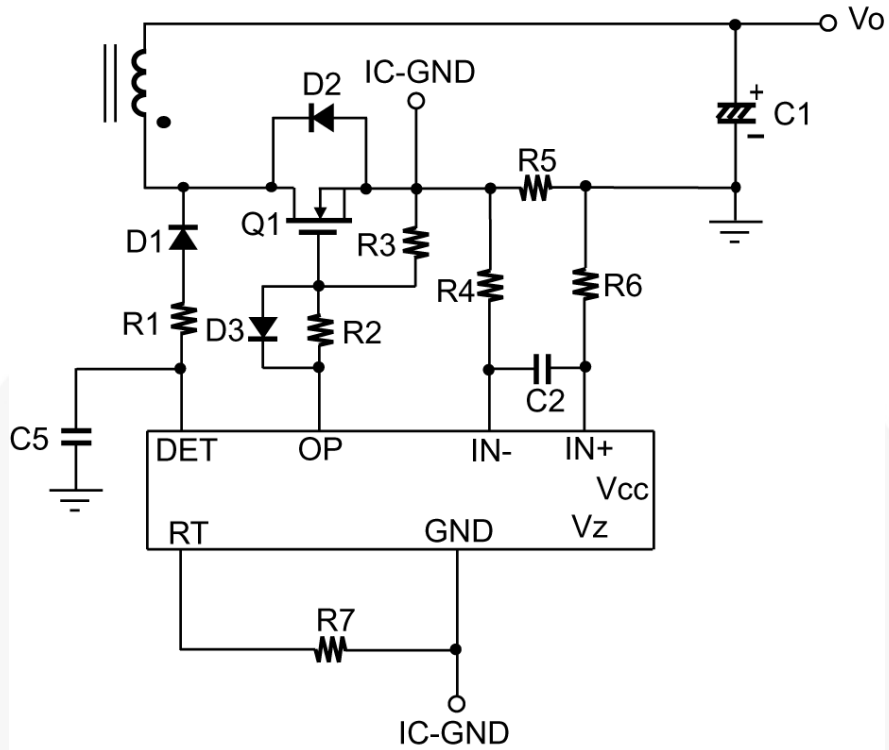

Synchronous Rectifier Controller for Flyback Converter

SG6203

PACKAGE INFORMATION
8 PINS-SOP(S)

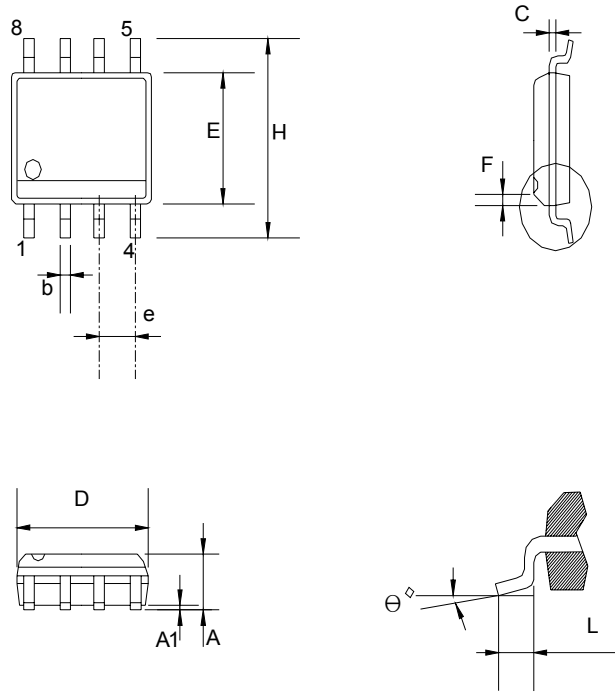

Dimensions

Symbol	Millimeter			Inch		
	Min.	Typ.	Max.	Min.	Typ.	Max.
A	1.346		1.752	0.053		0.069
A1	0.101		0.254	0.004		0.010
b		0.406			0.016	
c		0.203			0.008	
D	4.648		4.978	0.183		0.196
E	3.810		3.987	0.150		0.157
e	1.016	1.270	1.524	0.040	0.050	0.060
F		0.381X45°			0.015X45°	
H	5.791		6.197	0.228		0.244
L	0.406		1.270	0.016		0.050
θ°	0°		8°	0°		8°

Synchronous Rectifier Controller for Flyback Converter

SG6203

8PINS-DIP(D)

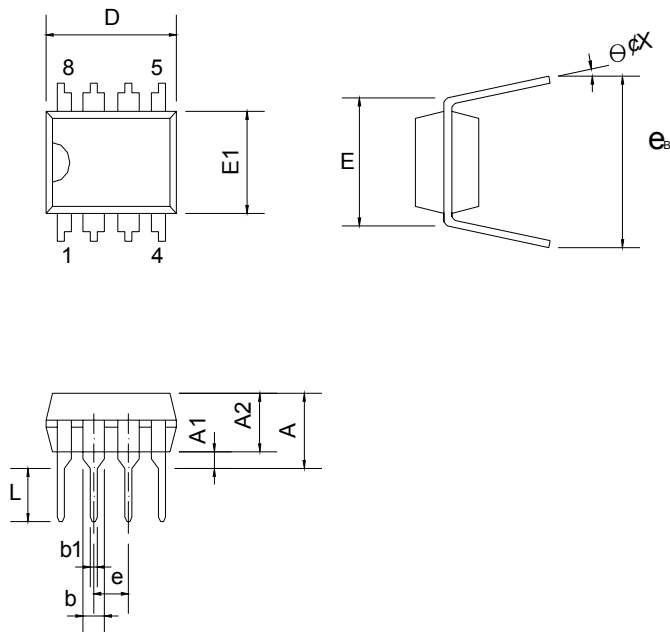

Dimension

Symbol	Millimeter			Inch		
	Min.	Typ.	Max.	Min.	Typ.	Max.
A			5.334			0.210
A1	0.381			0.015		
A2	3.175	3.302	3.429	0.125	0.130	0.135
b		1.524			0.060	
b1		0.457			0.018	
D	9.017	9.271	10.160	0.355	0.365	0.400
E		7.620			0.300	
E1	6.223	6.350	6.477	0.245	0.250	0.255
e		2.540			0.100	
L	2.921	3.302	3.810	0.115	0.130	0.150
e _B	8.509	9.017	9.525	0.335	0.355	0.375
θ°	0°	7°	15°	0°	7°	15°

Synchronous Rectifier Controller for Flyback Converter

SG6203



TRADEMARKS

The following are registered and unregistered trademarks and service marks Fairchild Semiconductor owns or is authorized to use and is not intended to be an exhaustive list of all such trademarks.

- | | | | |
|--------------------------------------|--|--|----------------------------------|
| ACEX [®] | Green FPS [™] | Power247 [®] | SuperSOT [™] -8 |
| Build it Now [™] | Green FPS [™] e-Series [™] | POWEREDGE [®] | SyncFET [™] |
| CorePLUS [™] | GTO [™] | Power-SPM [™] | The Power Franchise [®] |
| CROSSVOLT [™] | i-Lo [™] | PowerTrench [®] | the power franchise |
| CTL [™] | IntelliMAX [™] | Programmable Active Droop [™] | TinyBoost [™] |
| Current Transfer Logic [™] | ISOPLANAR [™] | QFET [®] | TinyBuck [™] |
| EcoSPARK [®] | MegaBuck [™] | QS [™] | TinyLogic [®] |
| F [®] | MICROCOUPLER [™] | QT Optoelectronics [™] | TINYOPTO [™] |
| Fairchild [®] | MicroFET [™] | Quiet Series [™] | TinyPower [™] |
| Fairchild Semiconductor [®] | MicroPak [™] | RapidConfigure [™] | TinyPWM [™] |
| FACT Quiet Series [™] | MillerDrive [™] | SMART START [™] | TinyWire [™] |
| FACT [®] | Motion-SPM [™] | SPM [®] | μSerDes [™] |
| FAST [®] | OPTOLOGIC [®] | STEALTH [™] | UHC [®] |
| FastvCore [™] | OPTOPLANAR [®] | SuperFET [™] | UniFET [™] |
| FPS [™] |  [®] | SuperSOT [™] -3 | VCX [™] |
| FRFET [®] | PDP-SPM [™] | SuperSOT [™] -6 | |
| Global Power Resource SM | Power220 [®] | | |

DISCLAIMER

FAIRCHILD SEMICONDUCTOR RESERVES THE RIGHT TO MAKE CHANGES WITHOUT FURTHER NOTICE TO ANY PRODUCTS HEREIN TO IMPROVE RELIABILITY, FUNCTION, OR DESIGN. FAIRCHILD DOES NOT ASSUME ANY LIABILITY ARISING OUT OF THE APPLICATION OR USE OF ANY PRODUCT OR CIRCUIT DESCRIBED HEREIN; NEITHER DOES IT CONVEY ANY LICENSE UNDER ITS PATENT RIGHTS, NOR THE RIGHTS OF OTHERS. THESE SPECIFICATIONS DO NOT EXPAND THE TERMS OF FAIRCHILD'S WORLDWIDE TERMS AND CONDITIONS, SPECIFICALLY THE WARRANTY THEREIN, WHICH COVERS THESE PRODUCTS.

LIFE SUPPORT POLICY

FAIRCHILD'S PRODUCTS ARE NOT AUTHORIZED FOR USE AS CRITICAL COMPONENTS IN LIFE SUPPORT DEVICES OR SYSTEMS WITHOUT THE EXPRESS WRITTEN APPROVAL OF FAIRCHILD SEMICONDUCTOR CORPORATION.

As used herein:

1. Life support devices or systems are devices or systems which, (a) are intended for surgical implant into the body or (b) support or sustain life, and (c) whose failure to perform when properly used in accordance with instructions for use provided in the labeling, can be reasonably expected to result in a significant injury of the user.
2. A critical component in any component of a life support, device, or system whose failure to perform can be reasonably expected to cause the failure of the life support device or system, or to affect its safety or effectiveness.

PRODUCT STATUS DEFINITIONS

Definition of Terms

Datasheet Identification	Product Status	Definition
Advance Information	Formative or In Design	This datasheet contains the design specifications for product development. Specifications may change in any manner without notice.
Preliminary	First Production	This datasheet contains preliminary data; supplementary data will be published at a later date. Fairchild Semiconductor reserves the right to make changes at any time without notice to improve design.
No Identification Needed	Full Production	This datasheet contains final specifications. Fairchild Semiconductor reserves the right to make changes at any time without notice to improve design.
Obsolete	Not In Production	This datasheet contains specifications on a product that has been discontinued by Fairchild Semiconductor. The datasheet is printed for reference information only.

Rev. 131