

REVISIONS					
P	LTR	DESCRIPTION	DATE	DMN	APVD
A		REVISED PER ECO-15-015252	16NOV15	BJ	FY

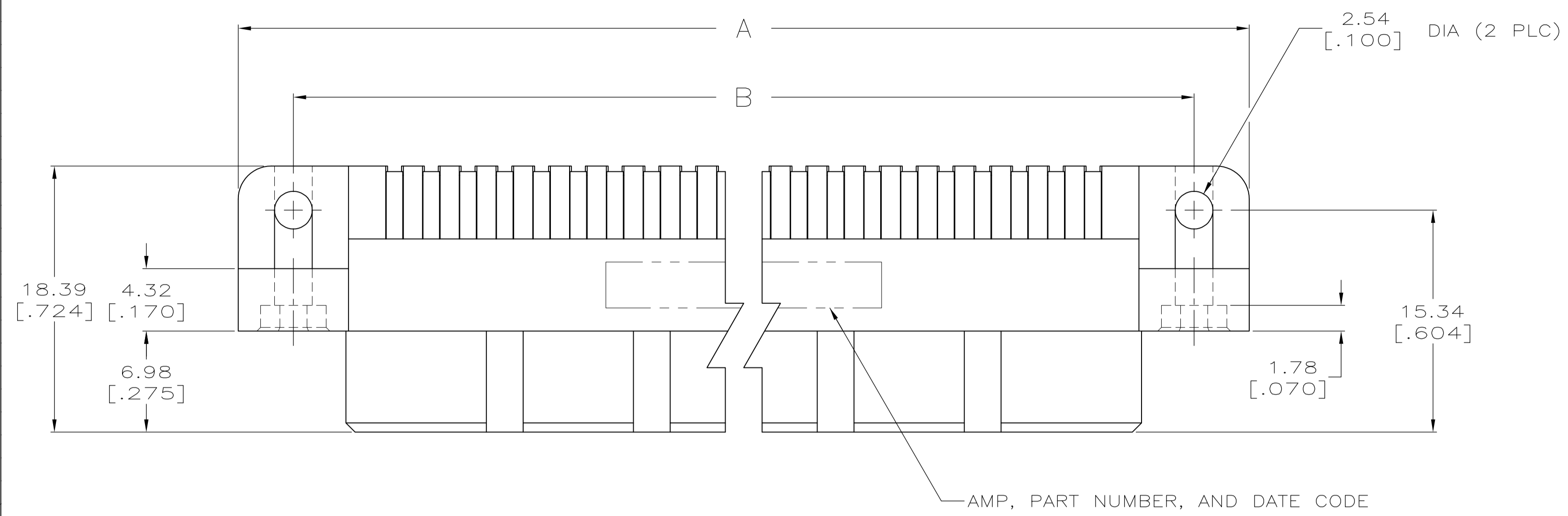

- 1 HOUSING MATERIAL: THERMOPLASTIC.
- 2 CONTACT MATERIAL: COPPER ALLOY.
- 3 FINISH:  
MATING AREA: MEETS THE PERFORMANCE REQUIREMENTS OF PRODUCT SPECIFICATION 108-9063; BASED ON TELCORDIA DR-1217-CORE APPLICATIONS IN UNCONTROLLED ENVIRONMENTS.  
TIN PLATED SOLDER TAILS.
- 4 SOLDER TAILS MUST FIT HOLE PATTERN AS SHOWN ON THE RECOMMENDED P.C. BOARD LAYOUT.
- 5 HOUSINGS WITH CENTER MOUNTING IS RECOMMENDED FOR ASSEMBLIES HAVING 75 CONTACTS PER ROW OR MORE.
- 6 OBSOLETE PARTS: OBSOLETE CIS STREAMLINING PER D.RENAUD/D.SINISI
- 7 FINISH:  
CONTACT FINISH: .00127-.00254 [.000050-.000100] NICKEL UNDERPLATE ALL OVER; .000762 [.000030] GOLD PLATE IN CONTACT AREA, TIN PLATED SOLDER TAILS.

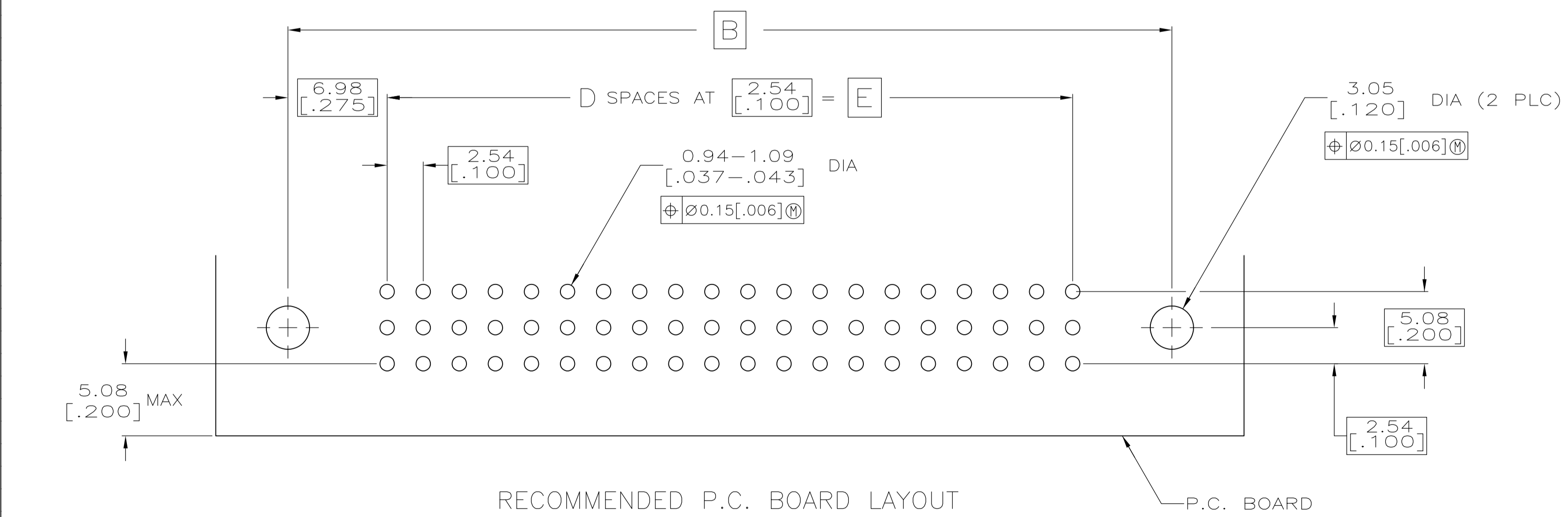
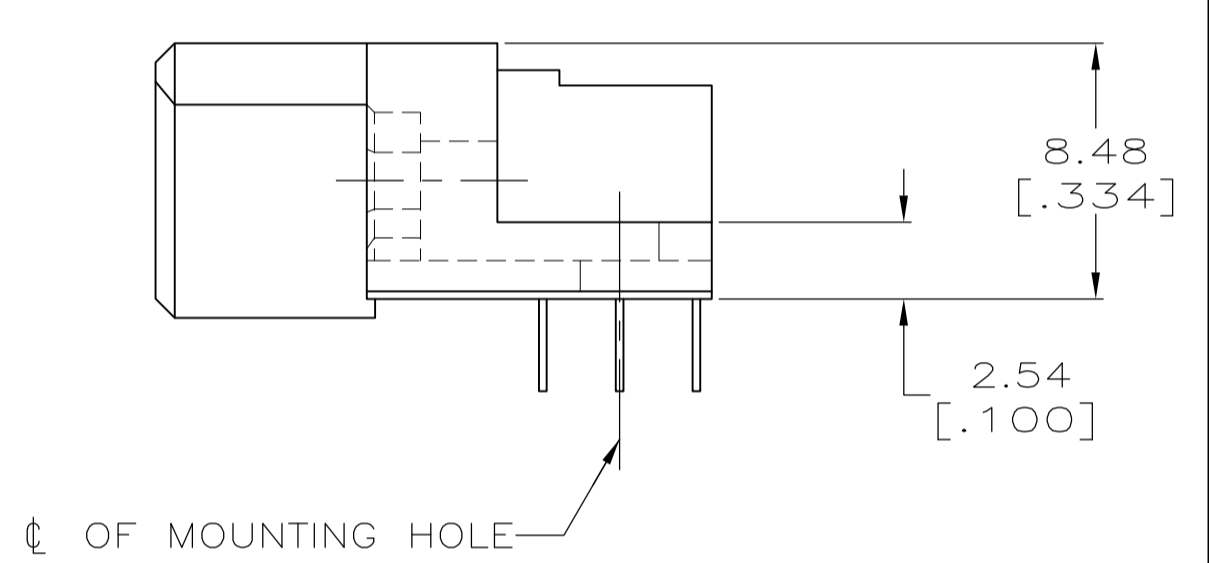
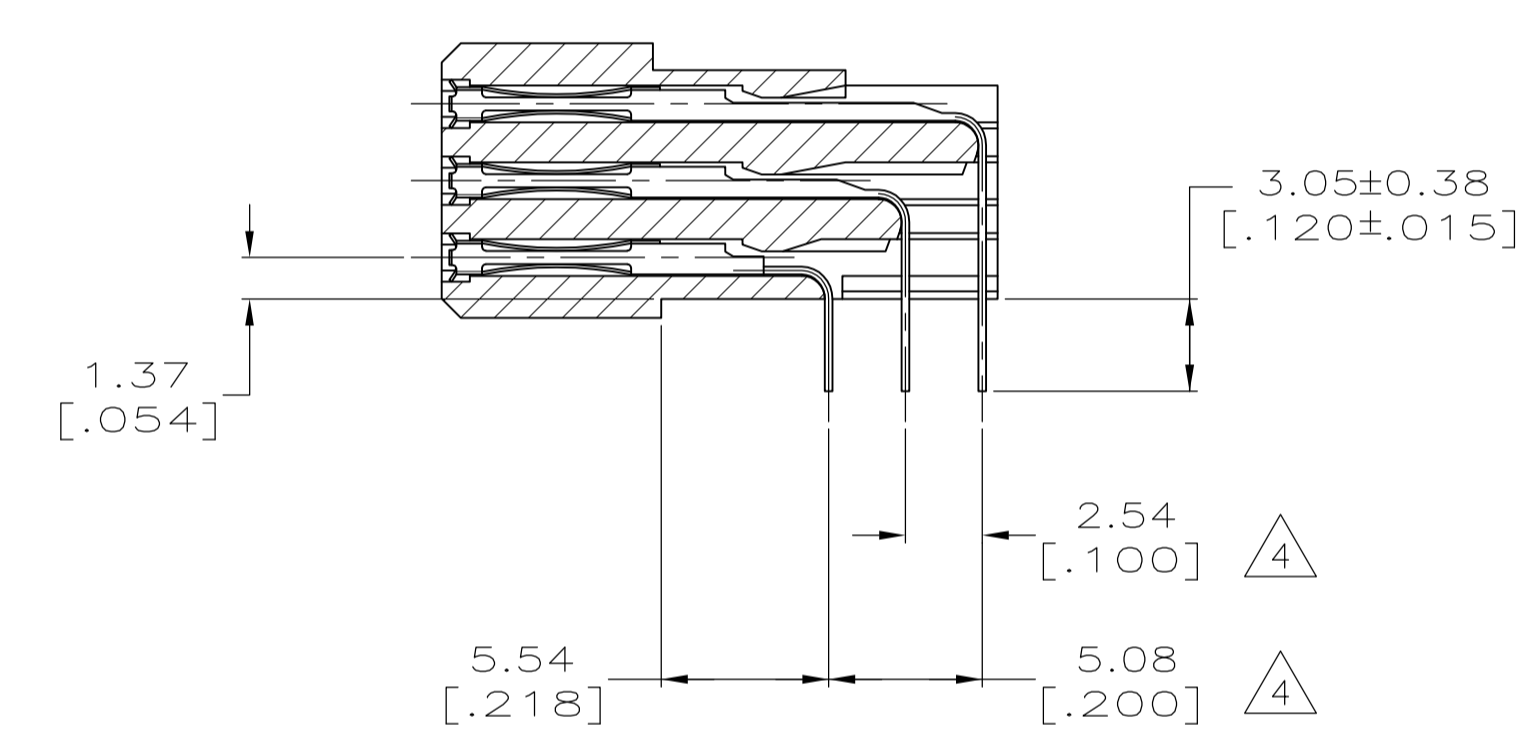
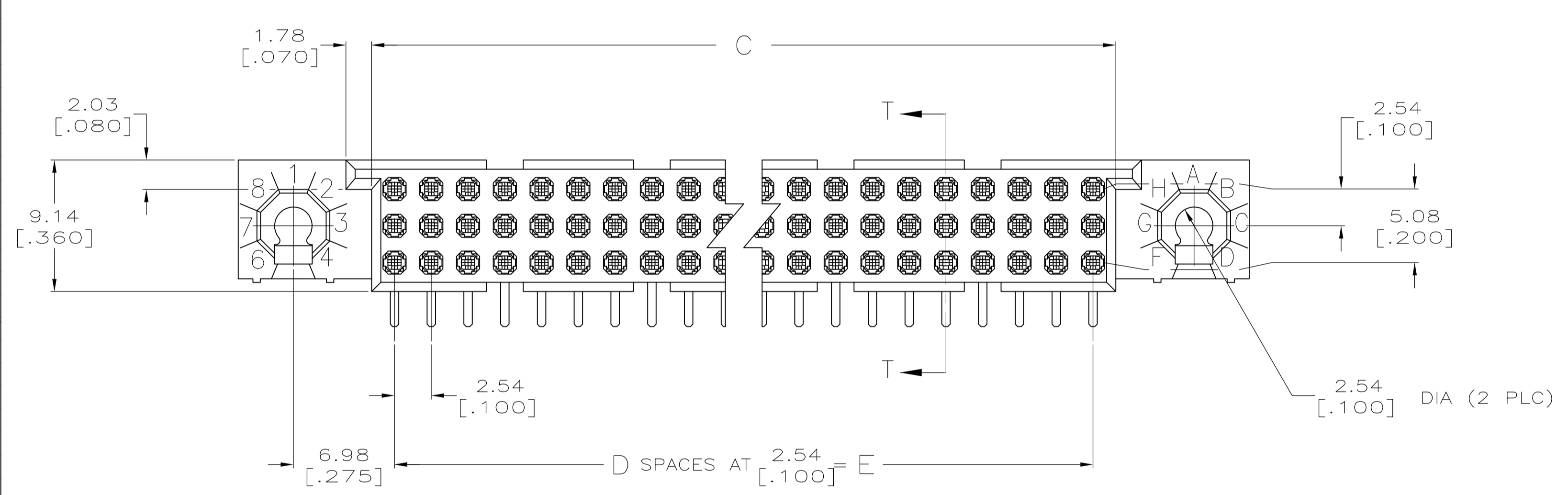

5/6 OBSOLETE	200.66 [7.900]	79	203.81 [8.024]	214.63 [8.450]	222.25 [8.750]	240	1-5533268-3
5	187.96 [7.400]	74	191.11 [7.524]	201.93 [7.950]	209.55 [8.250]	225	1-5533268-2
7	149.86 [5.900]	59	153.01 [6.024]	163.83 [6.450]	171.45 [6.750]	180	5533268-9
6 OBSOLETE	137.16 [5.400]	54	140.31 [5.524]	151.13 [5.950]	158.75 [6.250]	165	5533268-8
	124.46 [4.900]	49	127.61 [5.024]	138.43 [5.450]	146.05 [5.750]	150	5533268-7
6 OBSOLETE	111.76 [4.400]	44	114.91 [4.524]	125.73 [4.950]	133.35 [5.250]	135	5533268-6
	99.06 [3.900]	39	102.21 [4.024]	113.03 [4.450]	120.65 [4.750]	120	5533268-5
	78.74 [3.100]	31	81.89 [3.224]	92.71 [3.650]	100.33 [3.950]	96	5533268-3
	E	D	C	B	A	POSN	PART NUMBER

THIS DRAWING IS A CONTROLLED DOCUMENT. DIMENSIONS: mm [INCHES]. TOLERANCES UNLESS OTHERWISE SPECIFIED: 0 PLC ±, 1 PLC ±, 2 PLC ±, 3 PLC ±, 4 PLC ±, ANGLES ±.

DIN J. POLIGNONE 10JUN05  
 CJK A. SHARPE 10JUN05  
 APVD A. SHARPE 10JUN05  
 PRODUCT SPEC  
 APPLICATION SPEC

STE TE Connectivity  
 NAME ASSEMBLY, RECEPTACLE, RIGHT ANGLE, HDI, LEAD-FREE, 3 ROW, WITHOUT GUIDES, 3.05[.120] SOLDER TAILS  
 SIZE CAGE CODE DRAWING NO. RESTRICTED TO  
 WEIGHT A1 00779 5533268  
 CUSTOMER DRAWING SCALE 4:1 SHEET 1 OF 1 REV A