

Customer Information Sheet

DRAWING No.: M80-5L100M4-40-333

SHEET 2 OF 2

IF IN DOUBT - ASK

©

NOT TO SCALE

THIRD ANGLE PROJECTION

ALL DIMENSIONS IN mm

OBSOLETE

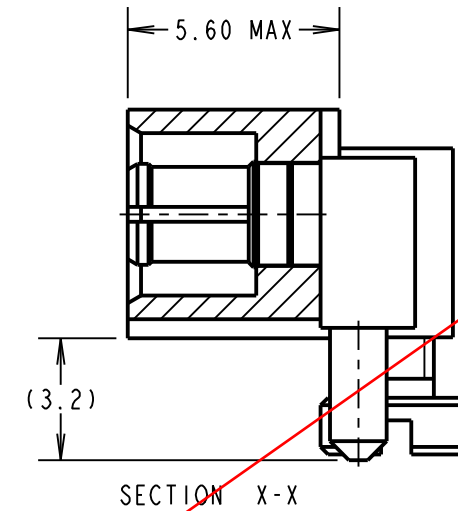
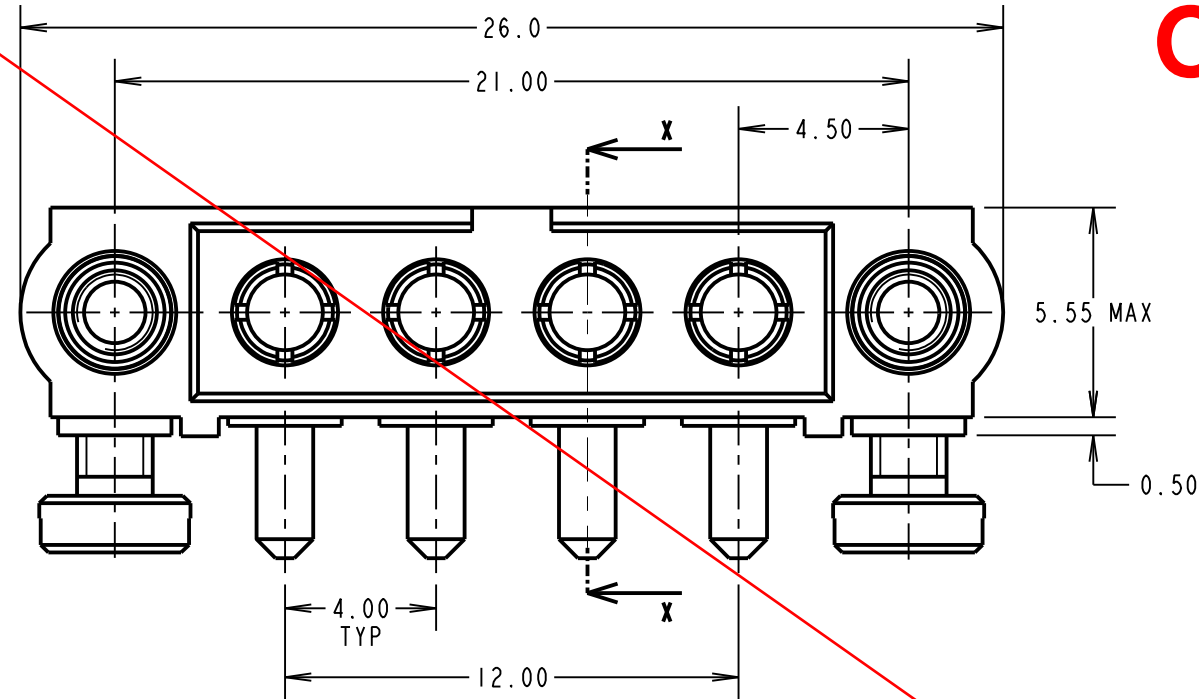

SPECIFICATIONS:
MATERIAL:
 MOULDING = GLASS-FILLED PPS, UL94V-0, BLACK
 JACKSCREW = STAINLESS STEEL
 POWER CONTACT = COPPER ALLOY
FINISH:
 POWER CONTACT = 0.25 - 0.3µ ALL OVER GOLD
ELECTRICAL:
 WORKING VOLTAGE = 800V AC/DC
 VOLTAGE PROOF = 1200V AC/DC
 INSULATION RESISTANCE = 100MΩ MIN
 CURRENT RATING = 20A MAX
 CONTACT RESISTANCE = 6mΩ MAX
MECHANICAL:
 DURABILITY = 500 OPERATIONS
 INSERTION FORCE = 8N MAX
 WITHDRAWAL FORCE = 0.5N MIN
ENVIRONMENTAL:
 TEMPERATURE RANGE = -55°C TO +125°C
PACKING:
 TUBE
 FOR COMPLETE SPECIFICATION, SEE COMPONENT SPECIFICATION C005XX (LATEST ISSUE)

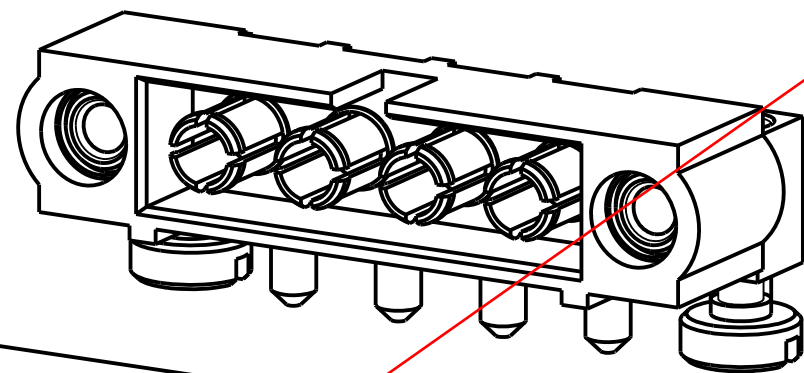
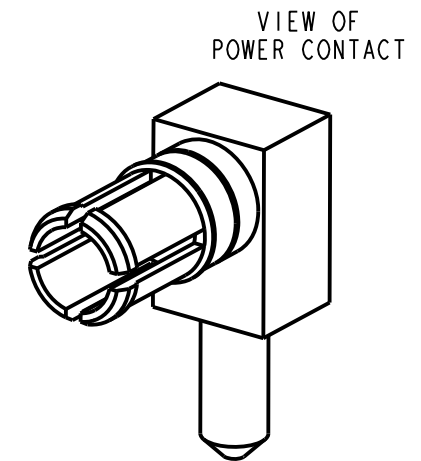
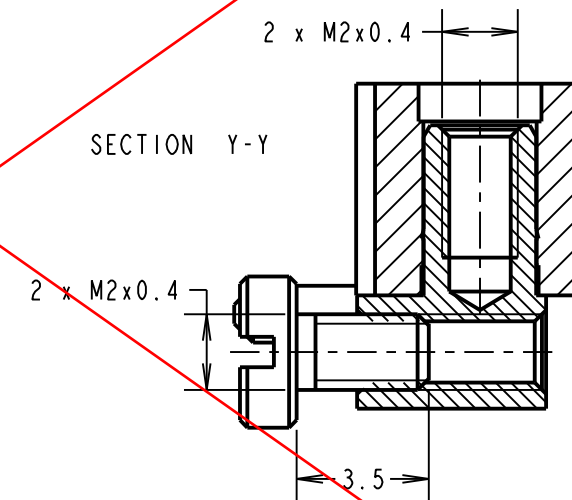
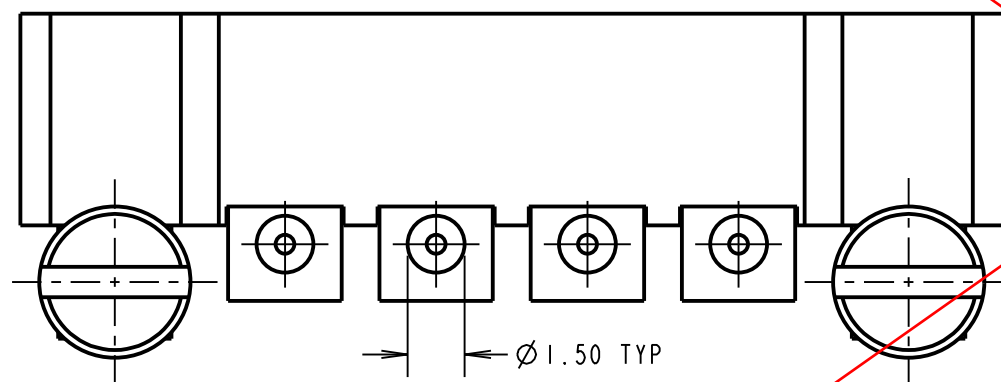

COMPLETE ASSEMBLY SHOWN FOR ILLUSTRATION ONLY

RECOMMENDED PCB LAYOUT

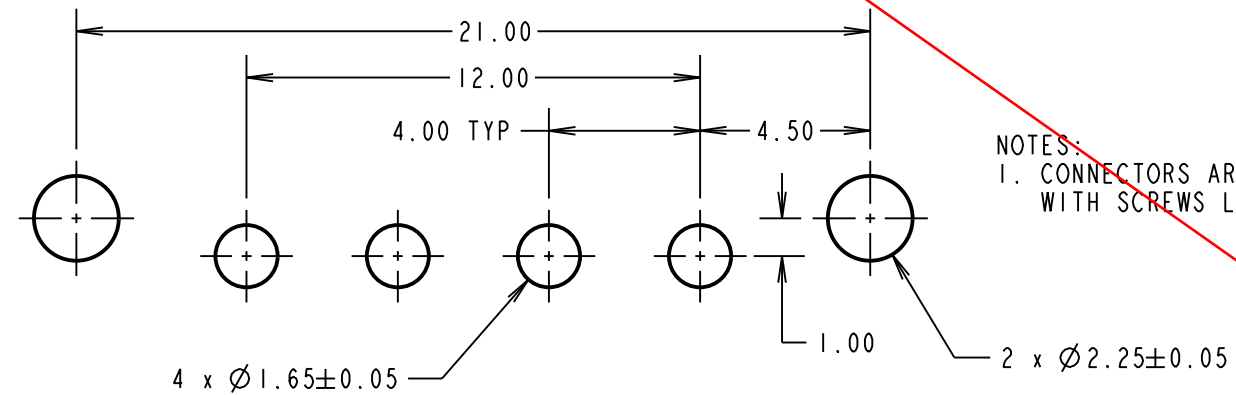

NOTES:
 1. CONNECTORS ARE SUPPLIED WITH SCREWS LOOSE.

LS	2	13.10.17	13269
NAME	ISS.	DATE	C/NOTE
APPROVED: LS			
CHECKED: SB			
DRAWN: MARK G PLESTED			
CUSTOMER REF.:			
ASSEMBLY DRG:			

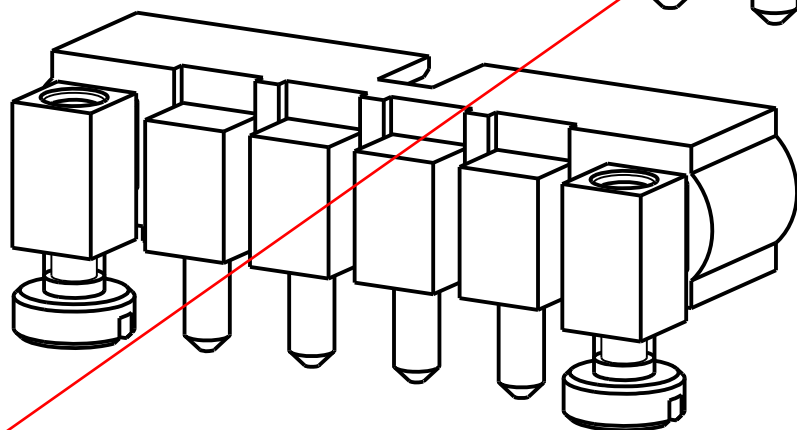

 www.harwin.com technical@harwin.com	THIS DRAWING AND ANY INFORMATION OR DESCRIPTIVE MATTER SET OUT HEREON ARE CONFIDENTIAL AND COPYRIGHT PROPERTY OF THE HARWIN GROUP AND MUST NOT BE DISCLOSED, LOANED, COPIED OR USED FOR MANUFACTURING, TENDERING OR FOR ANY OTHER PURPOSE WITHOUT THEIR WRITTEN PERMISSION.	TOLERANCES X. = ±1mm X.X = ±0.50mm X.XX = ±0.10mm X.XXX = ±0.01mm ANGLES = ±5° UNLESS STATED	MATERIAL: SEE ABOVE FINISH: SEE ABOVE S/AREA: mm ²	TITLE: JACKSCREW DATAMATE MIXED TECHNOLOGY HORIZONTAL PC TAIL MALE ASSEMBLY DRAWING NUMBER: M80-5L100M4-40-333	SHT 2 OF 2
--	---	---	---	--	---------------